

Module 1: Solar Power

6th Grade

About the Instructions:

This document is intended for use by classroom teachers, SciTrek leads, and SciTrek mentors. The document has been composed with input from teachers, leads, mentors, and SciTrek staff to provide suggestions for future teachers/leads/mentors. The instructions are not intended to be used as a direct script, but were written to provide teachers/leads/mentors with a guideline to present the information that has worked in the past. Teachers/leads/mentors should feel free to deviate from the instructions to help students reach the learning objectives of the module. Places in which you can be creative and mold the program to meet your individual teaching style, or to meet the needs of students in the class are: during class discussions, managing the groups/class, generating alternative examples, and asking students leading questions. However, while running the module, make sure to cover all the material each day within the scheduled 60 minutes. In addition, no changes should be made to the academic language surrounding the analysis activity.

This 6th grade module has been designed to build upon the scientific practice taught in 5th grade SciTrek, which is conclusions. If students did not have 5th grade SciTrek, they should do the 6th grade module with conclusion as their highlighted scientific practice instead of analyzing and interpreting data.

Activity Schedule:

There are no scheduling restrictions for this module.

Day 1: Analysis Assessment/Observations/Technique/Variables (60 minutes)

Day 2: Question/Materials Page/Experimental Set-Up/Procedure/Results Table (60 minutes)

Day 3: Experiment/Analysis Activity/Conclusion (60 minutes)

Day 4: Technique/Analysis Activity (60 minutes)

Day 5: Technique/Team Plan/Question/Experimental Set-Up/Procedure/Results Table (60 minutes)

Day 6: Experiment/Graph/Conclusion (60 minutes)

Day 7: Poster Making/Poster Presentations (60 minutes)

Day 8: Analysis Assessment/Tie to Standards (60 minutes)

The exact module dates and times are posted on the SciTrek website (scitrek.chem.ucsb.edu/elementary) under the school/teacher. The times on the website include transportation time to and from outside of Chem 1204. Thirty minutes are allotted for transportation before and after the module. Therefore, if a module was running from 10:00-11:00, then the module times on the website would be from 9:30-11:30.

Student Groups:

For the initial observation (Day 1), students work in three groups of approximately ten students each. After Day 1, the groups of approximately ten students are further subdivided into two subgroups, approximately five students each, for the rest of the module. On Day 5, subgroups will join to form "teams" (two subgroups per team), based on the changing variable they choose to investigate. One mentor is assigned to help each group/team (which is made up of two subgroups). We find groups/subgroups work best when they are mixed levels and mixed language abilities.

NGSS Performance Expectation Addressed:

MS-ESS3-3 Apply scientific principles to design a method for monitoring and minimizing human impact on the environment.*

Common Core Mathematics Standard Addressed:

6.RP.3.C Find a percent of a quantity as a rate per 100 (e.g., 30% of a quantity means 30/100 times the quantity); solve problems involving finding the whole, given a part and the percent.

Learning Objectives:

1. Students will know how to calculate percentages.
2. Students will know that power is a measure of the energy of a system over time and be able to calculate power.
3. Students will know how to read a light bulb package to understand how much power the lightbulb needs allowing them to pick bulbs that minimize their power usage.
4. Students will know they must only have one changing variable in order to draw a conclusion.
5. Students will be able to determine whether a conclusion is appropriate based on a given data set.
6. Students will be able to recognize and interpret trends in graphical data and use that data to make predictions.
7. Students will be able to collaborate as a class to plan and carry out, a focused experiment.
8. Students, in small groups, will be able to select a question and make experiment decision that allows them to answer their question and present their findings to the class.
9. Students will be able to list at least two ways they behaved like scientists.

Classroom Teacher Responsibilities:

In order for SciTrek to be sustainable, the program needs to work with teachers on developing their abilities to run student-centered, inquiry-based science lessons on their own in their classrooms. As teachers take over the role of SciTrek lead, SciTrek will expand to additional classrooms. Even when teachers lead the modules in their own classrooms, SciTrek will continue to provide mentors and all of the materials needed to run the module. Below is a sample timeline for teachers to take over the role as the SciTrek lead.

*Groups are made up of approximately ten students and are subdivided into two subgroups (approximately five students each) after Day 1 of the module.

1. Year 1
 - a. Classroom teacher leads a group (Role: Group Lead; this is referred to as a mentor in these instructions)
2. Year 2
 - a. Classroom teacher co-leads the modules with a SciTrek staff member (Role: Co-Lead)
 - i. Classroom teacher will be responsible for leading entire class discussions (Ex: analysis activity).
 - ii. Classroom teacher will be responsible for time management.
 - iii. Classroom teacher will be responsible for overseeing mentors and helping any groups who are struggling.
 - iv. Classroom teacher will be responsible for all above activities. The SciTrek co-lead will only step in for emergencies.
 - v. The SciTrek co-lead will run the tie to standards activity.
3. Year 3 and beyond
 - a. Classroom teacher leads the modules (Role: Lead)
 - i. Classroom teacher will be responsible for leading entire class discussions (Ex: analysis activity).
 - ii. Classroom teacher will be responsible for time management.
 - iii. Classroom teacher will be responsible for overseeing mentors and helping any groups who are struggling.

- iv. For year 3 a SciTrek staff member will co-lead the tie to standards activity with the classroom teacher, for subsequent years they will run the tie to standards independently.

SciTrek staff is counting on teacher involvement. Teachers should notify the SciTrek staff if they will not be present on any day(s) of the module. Additional steps can be taken to become a SciTrek lead faster than the proposed schedule above. Contact scitrekelementary@chem.ucsb.edu to learn more.

In addition, teachers are required to come to UCSB for the module orientation, approximately one week prior to the start of the module. Contact scitrekelementary@chem.ucsb.edu for exact times and dates, or see our website at scitrek.chem.ucsb.edu/elementary under your class's module times. At the orientation, teachers will go over module content, learn their responsibilities during the module, and meet the mentors who will be helping in their classroom. Failure to come to the module orientation might result in loss of priority registration for the following year. If you are not able to come to the orientation at UCSB, you must complete an online orientation. Failure to complete an orientation for the module will result in loss of priority registration for the following year.

Prior to the Module (at least 1 week):

1. Come to the SciTrek module orientation at UCSB.

Notes for Teachers During the Module:

If possible, have a document camera available to the SciTrek lead every day of the module. If you do not have a document camera, please tell a SciTrek staff member at orientation.

Day 1:

Have students' desks/tables moved into three groups and cleared off. We will need to have access to three electrical plugs (one for each group).

Day 2-7:

Have students' desks/tables moved into six groups and cleared off.

Day 3 and 6:

We will need to have access to six electrical plugs (one for each subgroup).

Day 8:

Have students' desks/tables cleared off. The desks/tables do not need to be moved into groups.

Scheduling Alternatives:

Some teachers have expressed interest in giving the students more time to work with the mentors throughout the module. Below are options that will allow the students more time to work with the mentors. If you plan to do any of the following options, please inform the SciTrek staff no later than your orientation date (approximately one week before your module, exact orientation times are found at: scitrek.chem.ucsb.edu/elementary). This will allow the SciTrek staff to provide you with all needed materials.

Day 1:

If you would like to have more time for your students to make observations and generate variables, you can give the analysis assessment to your class, **before** SciTrek arrives.

Day 2:

If you would like to have more time for your students to design their experiments, you can do the example question/experimental set-up, outlined in the Introduction with your class, **before** SciTrek arrives.

Day 3:

If you would like to have more time for your students to perform their experiments, you can have students finish their conclusions, **after** SciTrek leaves.

Day 4:

If you would like to have more time for your students to work on the technique and analysis activities, you can either start the technique activity (notebook, pages 13 and 14) with your class, **before** SciTrek arrives or finish the analysis activity (notebook, pages 15-18) with your class, **after** SciTrek leaves.

Day 5:

If you would like to have more time for your students to collaborate and redesign their experiments, you can do the technique activity (notebook, pages 19-20) with your class, **before** SciTrek arrives.

Day 7:

If you would like to have more time for your students to discuss their experiments during poster presentations, you may take more time for each presentation and finish the presentations with your class, **after** SciTrek leaves.

Day 8:

If you would like more time for the tie to standards activity, you may give the analysis assessment to your class, **before** SciTrek arrives.

Materials Used for this Module:

1. Infrared Thermometers (Amazon.com: Etekcity Lasergrip 774 IR Thermometer) Students will read the temperature to the nearest whole number. Therefore, to make it easier for them a Sharpie was used to black out the decimal places. See picture (right) for example.
2. Extension cords
3. Clear rulers (Amazon.com: eBoot clear plastic ruler, 12-inch/metric)
4. Wooden Rulers (Office Depot Part Number: 21215472)
5. Battery connect snaps 9V 6" leads (Digi-Key part number: BS6I-MC-ND). 22-18 gauge crimp butt connectors (pink) were used to connect ~1 inch of solid core copper with (20 gauge) to the battery connect snaps.
6. 2x1.5 V AAA Battery Holder Case Box with red and black wire. 22-18 gauge crimp butt connectors (pink) were used to connect ~1 inch of solid core copper with (20 gauge) to the battery holders (Amazon)
7. Breadboard strip 1.80x1.40" (Digi-Key part number: 1738-1321-ND). To make sure the LED is oriented correctly in the breadboard, the breadboard was labelled by coloring 1 port red and 1 port black to correspond with the correct LED leg. See picture below for example.

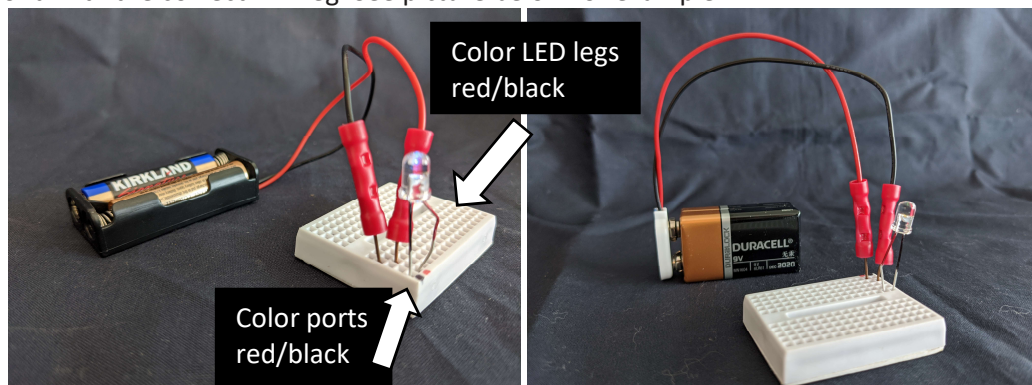
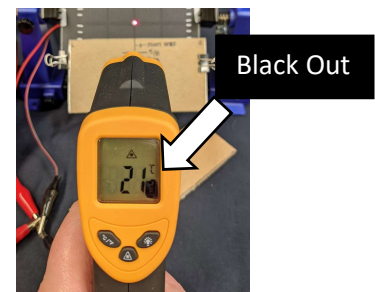

8. Vernier KidWind 2V/400 mA Solar Panel (Fisher part number: S04828ND). Students may shade their solar panel in their experiment. To indicate the position for the shading tool, a silver Sharpie was used to make a hash mark every 0.6 cm on the sensor portion of the solar panel to break it up into 8 equal portions. Students must also take the temperature of their panel. To indicate where to take the temperature, a silver dot is drawn (using a Sharpie) directly in the center of the panel (pictured below, left). To make it easier for students to position the solar panel, it will be placed in a circuit board holder. To indicate where to place the panel in the holder, a silver Sharpie was used to color in rectangles on either side of the panel between the 4/8 and 7/8 markers (pictured below, left). In addition, an arrow is drawn on the solar panel to ensure the solar panel is not placed in the holder upside down. When in the holder correctly the arrow will point up.

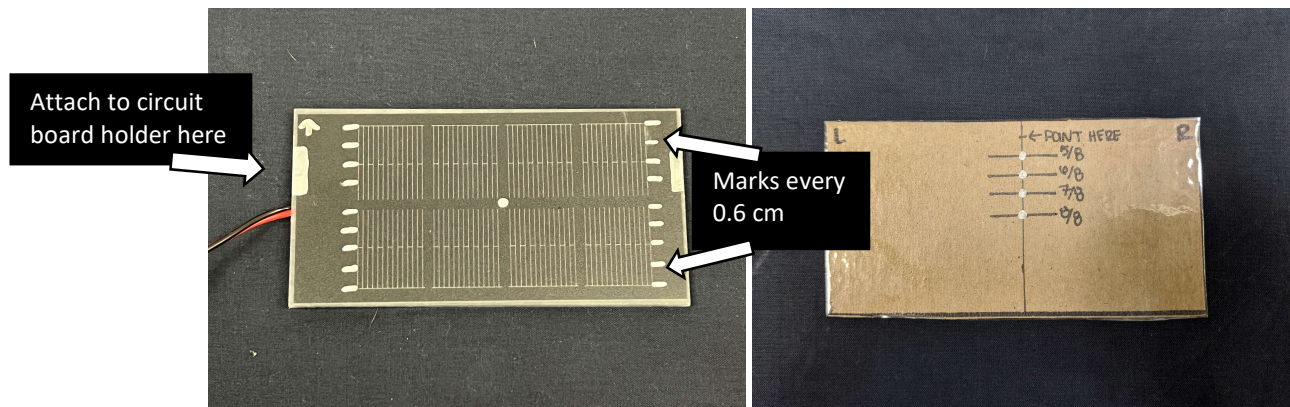

9. Cardboard for shading. In order to shade the solar panel, cardboard pieces (11.6 cm long \times 6 cm wide) were cut. Using a black Sharpie, a line was drawn from top to bottom at 5.5 cm. The longer side was labelled with an "L" for "left" and the shorter side was labelled with an "R" for "right." Starting from the top, 1 small line was drawn at 0.5 cm. From there, 4 lines were drawn every 0.6 cm. Each of those lines was then extended 1 cm on either side of the center line and labelled with a fraction ($\frac{5}{8}$ – $\frac{8}{8}$). On each of those 2 cm long lines, a silver Sharpie was used to draw a dot in the center of the line to signify the temperature would be taken at each of those shading amounts. The shading tools were then laminated so they will last longer (pictured above, right).

- a. We used the back of a poster paper pad, but any thin cardboard will work

10. Golden Apple, 5.5 oz black plastic Jell-O shot souffle cups with clear lids, sampling cup (Amazon). To make the LED light easier for students to see, these cups were modified to hold the LEDs by drilling a $\frac{11}{64}$ hole directly in the center of the cup. The LED was placed inside and hot glued to the base of the cup. See picture below for example.

11. LEDs. To ensure that LEDs are oriented correctly in the breadboard and when being clamped to the solar panel, the long leg was colored red to correspond to either the red port (breadboard) or red lead (solar panel) and the short leg was colored black to correspond to either the black port (breadboard) or black lead (solar panel). Additionally, to make the LED light easier to see, some LEDs were hot glued into the plastic cups. See picture above for example.



- a. White LED, 5 mm, 3.4 V, 20 mA, lens colorless, through hole (Digi-Key part number:160-1772-ND)
- b. Green LED, 5 mm, 2.1 V, 20 mA, lens green, through hole (Digi-Key part number:160-1702-ND)

- c. Red LED, 5 mm, 2 V, 20 mA, lens red, through hole (Digi-Key part number:160-1701-ND)
 - d. Blue LED, 5 mm, 3.5 V, 20 mA, lens color colorless, through hole (Digi-Key part number: 160-1610-ND)
12. Aven 1710 Adjustable Circuit Board Holders (amazon). These holders have been modified by adding four, 2 in, mending braces (Ace part number: 5292040). The braces are added to the side that does not have the spring on the holder. One brace goes on the inside of the holder and the other three braces go on the outside of the holder. The braces are held to the circuit board holder with two hex bolts ($\frac{1}{4} \times 1 \frac{1}{4}$) and two hex nuts ($\frac{1}{4}$). The height of the mending braces is adjusted to allow the origin of the swing arm protractor sits at the rotation point of the circuit board holder causing the braces to be about 2.5 cm from the top of the holder. The arms of the holder are set 140 cm apart and a line with is drawn, with silver sharpie, to show where the arms go. The lines allow you to easily see if the arms have moved so you can readjust them while working with students. See picture (right) for example.
 13. Spacing tool. To ensure the light is the correct distance from the solar panel, cardboard rectangles (14 cm tall \times 4.5 cm wide) were cut. Any thicker cardboard box will work. See picture (right) for example.
 14. Conair 1600-Watt compact hair dryer with folding handle; dual voltage travel hair dryers (Amazon)
 15. Goose neck desk lamp, Simple Designs LD1003-BLK Basic Metal Flexible Hose Neck Desk Lamp, Black (Amazon). 800 Lumen, 2,700 K LEDs are used as the light bulbs.
 16. 15 mm Binder clips
 17. Light bulbs
 - a. Ecosmart LED bulb (50-Watt Equivalent BR20 Dimmable CEC LED Light Bulb Daylight), 550 lumens, 120 V, 7 watt, 5000 K, 550 lumens (Home Depot part number: 1002965665)
 - b. Ecosmart compact florescent (40-watt equivalent E26 Spiral CFL Light Bulb Daylight (2-Pack)), 120 V, 9 watt, 5000 K, 500 lumens (Home Depot part number: 252763)
 - c. Philips, halogen bulb (40-Watt halogen clear decorative globe light bulb (3-pack)), 120 V, 40 W

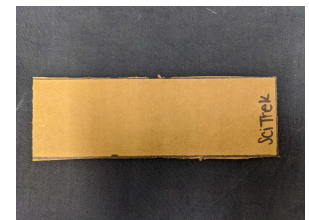

17. Amp meter Signstek UT210E handheld RMS AC/DC Mini Digital Clamp Meter Resistance Capacitance Tester (Amazon)
18. AstroAI Digital Multimeter with Ohm Volt Amp and Diode Voltage Tester Meter (Intelligent Anti-burn) (Amazon). Students will only read the current to the tenths place. Therefore, to make it easier for them, a Sharpie is used to black out the hundredths place. Additionally, to ensure that we get appropriate current readings between 0-20 mA, a black Sharpie is used to box the 20m setting on the multimeter. To ensure we get appropriate voltage readings between 0-20 V, a silver Sharpie is used to box the 20 setting on the multimeter. See picture below for example.
19. Proster Copper Banana Plug to Alligator Clip Test Lead 15A 1000C 1m (Amazon)
20. Cable Matters 2-Pack Hanging Light Cord (Light Socket with Cord) with On Off Toggle Switch in Black - 15 Feet. In order to measure the current flowing through one the wires, the double wires must be split in half on a portion of the wiring, as shown in the picture to the right.

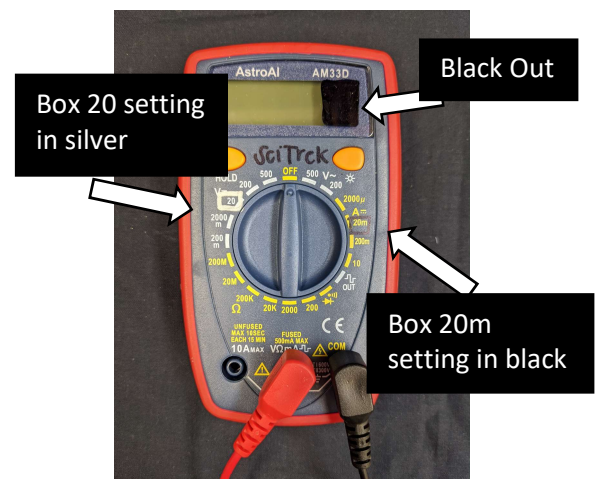

All printed materials used by SciTrek (notebooks, materials page, team plan page, picture packet, poster parts, instructions, and nametags) can be made available for use and/or editing by emailing scitrekelementary@chem.ucsb.edu.

Types of Documents:

Notebook:

One given to every student and is filled out by the student. The lead will use a notebook to write in as an example for students. The notebook the lead uses is referred to as the class notebook in these instructions.

Notepad:

One given to every group and is filled out by the mentor. In these instructions, the examples are narrower and taller than the notebook pages.

Picture Packet:

One per class that, if needed, the lead fills out. In these instructions, the examples are the same size as the notebook pages, but they are labeled.

In these instructions, all other example documents are labeled.

Day 1: Analysis Assessment/Observations/Technique/Variables

Schedule:

Introduction (SciTrek Lead) – 2 minutes
 Analysis Assessment (SciTrek Lead) – 15 minutes
 Observation Discussion (SciTrek Lead) – 2 minutes
 Observations (SciTrek Mentors) – 13 minutes
 Technique (SciTrek Lead) – 12 minutes
 Variable Discussion (SciTrek Lead) – 5 minutes
 Variables (SciTrek Mentors) – 9 minutes
 Wrap-Up (SciTrek Lead) – 2 minutes

Materials:

(3) Mentor Boxes:

- | | | |
|---|--|---|
| <input type="checkbox"/> Student nametags | <input type="checkbox"/> (2) Dry erase markers | <input type="checkbox"/> Hair dryer |
| <input type="checkbox"/> (NS+1) Notebooks | <input type="checkbox"/> Ruler | <input type="checkbox"/> Multimeter |
| <input type="checkbox"/> Mentor instructions | <input type="checkbox"/> (12) Clear rulers | <input type="checkbox"/> Spacing tool |
| <input type="checkbox"/> Picture of experimental set-up | <input type="checkbox"/> Protractor | <input type="checkbox"/> Shading tool |
| <input type="checkbox"/> Mentor lab coat | <input type="checkbox"/> Solar panel | <input type="checkbox"/> (2) Binder clips (15 mm) |
| <input type="checkbox"/> (2) Pencils | <input type="checkbox"/> Solar panel holder | <input type="checkbox"/> Cup with red LED |
| | <input type="checkbox"/> IR thermometer | <input type="checkbox"/> Cup with blue LED |

Other Supplies:

- | | | |
|---------------------------------------|---|--|
| <input type="checkbox"/> (3) Notepads | <input type="checkbox"/> Calculator box | <input type="checkbox"/> Box of (4) lamps with (4) extension cords |
| <input type="checkbox"/> (3) Trays | | |

Lead Box:

- | | | |
|---|--|--|
| <input type="checkbox"/> (3) Blank nametags | <input type="checkbox"/> (3) Markers (orange, blue, green) | <input type="checkbox"/> Shading tool |
| <input type="checkbox"/> (3) Extra notebooks | <input type="checkbox"/> (2) Ruler | <input type="checkbox"/> (2) Binder clips (15 mm) |
| <input type="checkbox"/> Lead instructions | <input type="checkbox"/> (5) Clear rulers | <input type="checkbox"/> Container with 3 blue LEDs |
| <input type="checkbox"/> Solar Power picture packet | <input type="checkbox"/> (3) Protractors | <input type="checkbox"/> Breadboard |
| <input type="checkbox"/> Picture of experimental set-up | <input type="checkbox"/> (2) Solar panels | <input type="checkbox"/> AAA battery pack with batteries (batteries must be new) |
| <input type="checkbox"/> Lead lab coat | <input type="checkbox"/> Solar panel holder | <input type="checkbox"/> 9 V battery pack with battery (batteries must be new) |
| <input type="checkbox"/> (35) Analysis assessments | <input type="checkbox"/> IR thermometer | <input type="checkbox"/> Cup with red LED |
| <input type="checkbox"/> Time card | <input type="checkbox"/> Hair dryer | <input type="checkbox"/> Cup with blue LED |
| <input type="checkbox"/> (2) Pencils | <input type="checkbox"/> (2) Multimeters | |
| <input type="checkbox"/> (2) Wet erase markers | <input type="checkbox"/> Spacing tool | |
| <input type="checkbox"/> (2) Black pens | | |

Notepad and Notebook Pages:

OBSERVATIONS

Experimental Set-Up:

Other observations of the experimental set-up:

- Thermometer
- Room temperature = 21°C
- Hair dryer

Describe what happened during the experiment.

- We heated the solar panel to 30°C using the hair dryer.
- We measured the current and voltage using the multimeter.

Solar Panel Measurements	
Current (mA)	5.2 mA
Voltage (V)	1.9 V

1

OBSERVATIONS

Experimental Set-Up:

Draw a picture of the experimental set-up below and label the parts of the system.

Other observations of the experimental set-up:

- Thermometer
- Room temperature = 21°C
- Hair dryer

Describe what happened during the experiment.

- We heated the solar panel to 30°C using the hair dryer
- We measured the current and voltage using the multimeter

Solar Panel Measurements	
Current (mA)	5.2 mA
Voltage (V)	1.9 V

When the red LED was hooked up to the solar panel it lit did not light. (circle one)

When the blue LED was hooked up to the solar panel it lit did not light. (circle one)

2

TECHNIQUE
Calculating Power

One way to measure the energy of our system over time is by calculating the **power** of the system. Power (P) can be found by multiplying the current (I) measured in milliamps (mA) and voltage (V) measured in volts (V) of the system together:

$$P = I \times V$$

For this experiment, power is calculated in units called **milliwatts** (mW).

Directions: Calculate the power produced by each system. Round your answer to the nearest tenth (Ex: 9.5 mW).

a) Class Solar Panel $I = 2.9 \text{ mA}$ $V = 1.8 \text{ V}$ $P = 2.9 \text{ mA} \times 1.8 \text{ V}$ $= 5.2 \text{ mW}$	b) Round Batteries $I = 3.8 \text{ A}$ $V = 3.1 \text{ V}$ $P = 3.8 \text{ A} \times 3.1 \text{ V}$ $= 11.8 \text{ W}$
c) Rectangular batteries $I = 2.4 \text{ A}$ $V = 8.6 \text{ V}$ $P = 2.4 \text{ A} \times 8.6 \text{ V}$ $= 20.6 \text{ W}$	d) Your Solar Panel $I = 5.2 \text{ mA}$ $V = 1.9 \text{ V}$ $P = 5.2 \text{ mA} \times 1.9 \text{ V}$ $= 9.9 \text{ mW}$

1. What does our experiment tell us about the red and blue LEDs?
They require a certain amount of power to work.
2. What happens when the blue LED is touched to the round batteries? It lights up.
3. What happens when the blue LED is touched to the rectangular battery? It blows up.
4. Why does this happen? Too much power was applied.
5. What does this tell us about lights/devices? They operate under specific conditions and too much power can be harmful.
6. How can we monitor the amount of power used by a device? We can measure the current and voltage to calculate power usage.

3

VARIABLES

Variable	How will changing this variable affect the power produced by a solar panel?
Panel Angle	Flatter panels (closer to 0°), will produce _____ power because _____.
Light Brightness	Brighter lights, will produce _____ power because _____.
Light Source	Natural light (like the sun), will produce _____ power because _____.
Choose your own!!	

2

VARIABLES

Variable	How will changing this variable affect the power produced by a solar panel?
Panel Angle	Flatter panels (closer to 0°) will produce more power because the light will hit the panel more directly.
Light Brightness	Brighter lights will produce more power because the light will be more intense over the panel.
Light Source	Natural light (like the sun) will produce more power because we normally use sunlight on solar panels.
Temperature	Higher temperatures will produce more power because the solar panel may break down when it gets too hot.
Dirt Amount	More dirt on the solar panel will produce less power because the panel will have dirt blocking the light.

4

Preparation:

SciTrek Lead:

1. Make sure mentors are passing out nametags.
2. Make sure mentors are setting up for the initial observation.
3. Set up the document camera for the analysis assessment, technique activity (notebook, page 3), and class question (notebook, front cover).
4. Set up the lead set-up.
 - a. Place a solar panel in the solar panel holder, turn the angle to 45°, and use the shading tool to shade $\frac{2}{8}$ of the panel.
 - b. Hook the multimeter up to the panel.
 - c. Place the AAA battery pack, 9 V battery, and breadboard near the lead set-up.
5. Pass out the analysis assessments.

SciTrek Mentors:

1. Pass out nametags.
 - a. You may need to do this during the Introduction. Quietly set each student's nametag on their desk without talking to them. If names are not written on their desk, ask the classroom teacher or lead to help you when they are not talking with the class.
2. Have rulers available to pass out.
3. Set the following materials on a tray: solar panel, solar panel holder, protractor, shading tool, 2 binder clips, spacing tool, multimeter, ruler, thermometer and hair dryer.
4. Plug lamp in with enough cord to be able to set it on the table you will be working at, if needed use an extension cord.
5. Have the red and blue LED cups in your lab coat pocket to use at the end of the observation section.

Introduction:

(2 minutes – Full Class – SciTrek Lead)

For UCSB Lead:

“Hi, we are scientists from UCSB and we want to show you what we do as scientists. We will show you an experiment and then you can make observations, come up with a class question, and design your own experiment to help answer the class question. We want to show you that you can do science and have fun.”

For Teacher Lead:

“I have asked some scientists from UCSB to come and help us with a long-term science investigation. We will make observations, come up with a class question, and you will design your own experiment to help answer the class question.”

Allow the UCSB mentors to introduce themselves and share their majors.

Analysis Assessment:

(15 minutes – Full Class – SciTrek Lead)

Tell students, “Before we start with the module, we will determine how your ideas on analyzing and interpreting data are developing.” Have students write their name, teacher’s name, and date at the top of the assessment. Tell students, “When doing this assessment, you should work individually, so there should be no talking.” As you are giving the assessment, walk around the room and verify students have written their names on their assessments.

For page 1, read the *Directions for annotating* to students. Then, have students annotate the first results table by underlining controls, circling changing variables, and boxing information about data collection (question 1a). Read question 1b (*Can this group make a conclusion?*) and have students answer circle *yes*, *no*, or *I do not know*. Have students annotate the possible conclusion (question 1c). Finally, read question 1d (*Is this a correct conclusion for the results table? If NO, what is wrong with the conclusion?*), and have students answer the question. Repeat this process for questions 2 and 3 (page 2, top).

For page 2 (bottom), have mentors pass out clear rulers to students. For question 4, you will show students how to annotate the graph. First, ask students, “What is on the x-axis (the horizontal axis)?” Students should reply, “Time.” Tell students, “The changing variable will always be found on the x-axis, so we should circle ‘time.’” Ask students, “Where else do you see ‘time’ on this graph?” They should reply, “In the title.” Circle *Time* in the graph title. Then, ask students, “What is being plotted on the y-axis, the vertical axis?” They should reply, “Distance traveled.” Tell students, “The data that was collected will always be found on the y-axis,” and box *Distance Traveled*. Then, ask students, “Do you see ‘distance traveled’ anywhere else on the graph?” They should notice the data in the graph title, and box *Distance Traveled*. Finally, point out the *Amount of Sand* is a special type of control called a group control that they will learn about later in the activity. Underline *Amount of Sand* in the legend and ask, “Where else do you see ‘amount of sand’ on this graph?” They should reply, “In the title.” Underline *amount of sand* in the graph title.

Students should answer the remaining questions on their own. Have students plot the remaining points on the graph using circles as markers. Then, tell students, “Draw trend lines for each experiment on the graph.” Read questions 4d-4f and give students time to answer each. When students are finished, collect the assessments and rulers as well as verify students’ names are written on top.

Observation Discussion:

(2 minutes – Full Class – SciTrek Lead)

Tell students, “Scientists make many observations.” Ask the class, “What is an observation? What are the types of things you can record for an observation?” If they have trouble, show them an object and let them make observations. Turn these specific observations into general features of an observation. Examples of possible general observations are: color, texture, size, weight, temperature, etc. Lead students to understand an observation is a description using your five senses.

Tell students, “In this experiment we are going to make observations of a solar panel.” Ask the class, “Do you know what solar panels are used for?” Lead students to understand solar panels take energy from the Sun and transfer it into electrical energy for us to use.

Tell students, “One of the scientific devices that we will be using is a multimeter.” Put a multimeter under the document camera. “Multimeters are tools that measure the amount of current and voltage being produced/used by an object. We will measure current in milliamps and voltage in volts. In order to record the current, you will turn the dial to the setting that is boxed in black, and in order to record the voltage, you will turn the dial to the setting that is boxed in silver. Later, I will show you how to calculate the energy per time from current and voltage measurements, but for now you should know, the more current and voltage the solar panel produces, the more electricity it produces.”

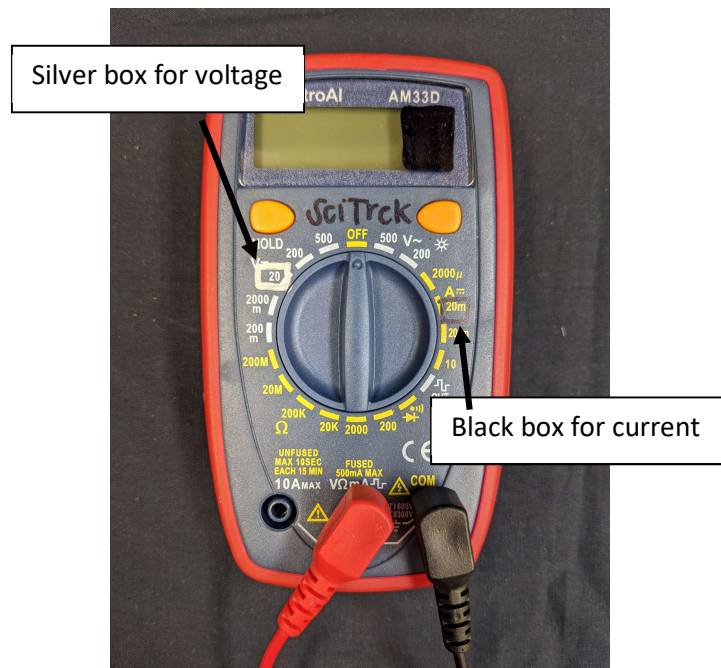

Tell students, “We will be using protractors to measure panel and light angles.” Put a protractor under the document camera. Show students that there are two scales on the protractor. Tell students, “So that we can compare data we want to make sure that we are all measuring from the same scale. Therefore, we will all use the clear scale of the protractor.”

Tell the class, “You will now get in your groups and make observations. To determine your group, you will need to look at the color of your nametag (orange, blue, or green).” Tell each colored group where to go, as well as to bring a pencil.

If a student does not have a nametag, identify the group color with the least number of students in it, and write the student’s name on one of the extra nametags in the lead box, using that color of marker.

Observations:

(13 minutes – Groups – SciTrek Mentors)

Once students come over to your group, have them sit in boy/girl fashion. Verify the tray of materials is set up as described in the Set-Up section then, set the tray and light in the middle of the table. Pass out a notebook to each student. Have students fill out their name, teacher’s name, group color (color of their name on their nametag: orange, blue, or green), and their mentor’s name on the front cover of their notebooks. Students will leave the subgroup number, team/subgroup symbol, and class question blank. Then, have students turn to page 2 of their notebooks.

Tell students, “I am now going to set up the experiment for you. You are going to watch me do it, and then you will record what I did in your notebook. The first thing we need to do is place the shading tool on the solar panel at the appropriate distance, and clip it on with binder clips. Before you do this make sure the arrow on the solar panel is pointing up” **With the arrow facing up, place the shading tool on the solar panel so that the bottom $\frac{2}{8}$ of the panel is shaded and clamp it on both sides using the binder clips.**

Tell students, “Now we need to **put the solar panel in the panel holder.**” To do this you need to have the word SciTrek on the panel holder facing you and the arrow on the solar panel is in the top left pointing away from you, then insert the solar panel into the middle holder slots, so it covers the silver rectangles on the sides of the panel.

Tell students, “Now we need to get the light at the correct distance from the solar panel. I will use the spacing tool to help do this.” **Make sure the solar panel is at 0°, then place the spacing tool straight up on the solar panel and bend the light so that it touches the top of the spacer.**

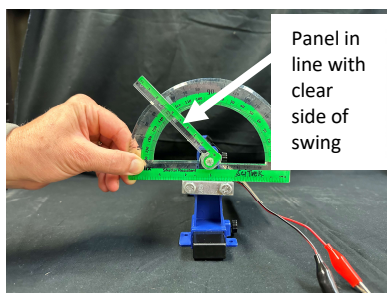

Tell students, “Next, we need to place the solar panel at the correct angle.” Remove the solar panel from under the light and set the protractor on the metal ledge. Move the swing arm until clear part of the swing arm lines up with the clear scale at 45°. Then **adjust the solar panel angle** so it is in line with the protractor at 45° (picture to the left). Allow students to look at the protractor and the angle to see how they will line it up for their experiments.

Return the solar panel to under the lamp. Tell students, “The last thing that we need to do is hook up the multimeter.” **Attach the multimeter to the solar panel by connecting the red wire of the multimeter to the red wire of the solar panel, and the black wire of the multimeter to the black wire of the solar panel.** A completed solar power set up is pictured below, left.

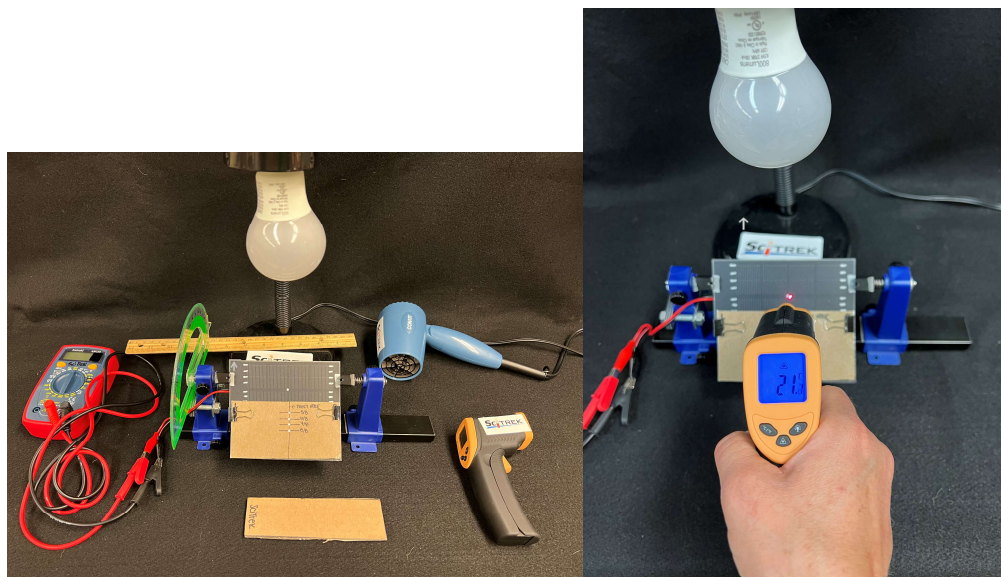

As a group, have students tell you what they observe as you put together the experimental set-up. Then, draw and label a picture of the items in the provided box on the notepad, while students copy the information into their notebooks. Other observations that are not in the picture should be recorded under *other observations of the experiment set-up*.

Tell students, “When we measure the current and voltage, we want the panel to be at a specific temperature. I will use the hair dry to heat the panel and the digital thermometer to monitor the temperature. The temperature the panel will be at when I take the measurements will be 30°C.” Demonstrate how to use the thermometer by pointing it perpendicular (90°) to the solar panel, and holding down the trigger so the laser shines on the silver dot in the center of the solar panel. Do not let students use the thermometer this day because laser safety has not been addressed by the lead. Allow students to read the measurement and record the room temperature. The complete experimental set-up should not take you longer than 7 minutes.

When you are ready to start the experiment, make sure the solar panel is returned to its original position under the lamp. Tell students, “We are now ready to start the experiment.” Have students remind you what to use to measure the current and voltage (a multimeter), and in what units each value is measured (milliamps for current, volts for voltage). Turn on the lamp. Assign one student to read the current and

voltage from the multimeter. Have that student turn the multimeter to the setting boxed in black; this will allow them to measure the current first. Tell them, “I will inform you when the solar panel is at the correct temperature, and you can read out the current; then, change the multimeter to the setting that is boxed in silver and read out the voltage.”

Put the hair dryer on high and hold it about 6 inches from the panel. Heat the panel for approximately 10 s. Remove the hair dryer from the solar panel and use the thermometer to check the temperature. If the temperature is below 30°C, heat the solar panel for approximately 10 s more and recheck the temperature. Continue doing this until the solar panel is approximately 32°C. Then, wait for the panel to cool to 30°C, and have the designated student tell the group the current and voltage produced. Record these values on the notepad while students copy them into their notebook. Then, have students write two bullets about what you did during the experiment.

Tell students, “One thing electricity can be used for is to light up lightbulbs. Therefore, we will look to see if our solar panel can light a red and a blue LED bulb.” Unhook the alligator clamps connecting the multimeter to the solar panel, and set the multimeter to the side. Take the red LED cup and connect it to the solar panel. The leg colored in red on the LED (long leg) should connect to the red wire of the solar panel, and the leg colored in black on the LED (short leg) should connect to the black wire of the solar panel (pictured below). Connect the alligator clamps on the uncolored portion of the LED legs. The red LED should light. Shine the light directly at each of the students to make sure they can see the LED lit up. If they are having trouble, place your hand over the solar panel to block the light (the LED should unlight) and remove your hand (the LED should light). Unhook the red LED and attach the blue LED in the same manor to the solar panel. The blue LED should not light. Again, make sure that each student sees the unlit LED. Unhook the LED and set it aside. Have students answer the two questions on the bottom of page 2 of their notebooks.

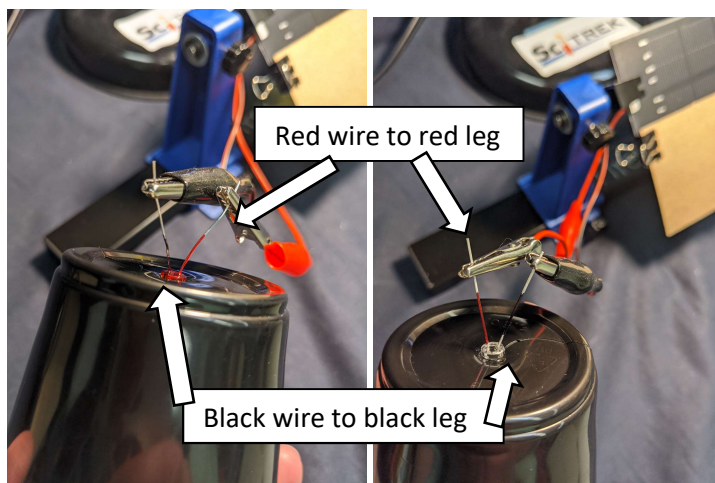

If there is additional time, have students make predictions about why the blue LED did not light. An example filled-out observations is shown below.

OBSERVATIONS

Experimental Set-Up:

Other observations of the experimental set-up:

- Thermometer • Room temperature = 21°C
- Hair dryer

Describe what happened during the experiment.

- We heated the solar panel to 30°C using the hair dryer.
- We measured the current and voltage using the multimeter.

Solar Panel Measurements	
Current (mA)	5.2 mA
Voltage (V)	1.9 V

1

OBSERVATIONS

Experimental Set-Up:
Draw a picture of the experimental set-up below and label the parts of the system.

Other observations of the experimental set-up:

- Thermometer • Room temperature = 21°C
- Hair dryer

Describe what happened during the experiment.

- We heated the solar panel to 30°C using the hair dryer
- We measured the current and voltage using the multimeter

Solar Panel Measurements	
Current (mA)	5.2 mA
Voltage (V)	1.9 V

When the red LED was hooked up to the solar panel it lit (circle one) did not light .

When the blue LED was hooked up to the solar panel it lit did not light (circle one).

2

Technique:

(12 minutes – Full Class – SciTrek Lead)

Ask the class questions to review the experiment they carried out, as well as what they learned about the ability of the set-up to light red and blue LEDs. Make sure by the end of the discussion, students have: described the set-up, identified the current and voltage they measured, and identified that the solar panel could light the red LED, but not the blue LED.

Tell students, “In your experiments you measured the current and voltage. Now I will show you how to turn these measurements into a scientific quantity called power. Power is the amount of energy per time that a device is using or supplying. Power can be calculated by multiplying the current in milliamps with the voltage in volts. When this is done, the units of power are milliwatts.” Have students turn to page 3 in their notebooks as you place the class notebook (opened to page 3) under the document camera. Have mentors pass out a calculator to each student.

Read the directions on page 3 to students (*Calculate the power produced by each system. Round your answer to the nearest tenth.*). Tell students, “First, we will calculate the power produced by a class solar panel.” Show students the class solar panel (this panel will not be under a lamp, you will just use the room light to generate energy). The class solar panel should be set up close enough to the document camera so the multimeter can be placed under it. Turn the dial on the multimeter to the setting boxed in black to measure the current. Tell students, “Current is represented by the letter I.” Record the current value in the class notebook under letter a, and have students copy it into their notebook. Turn the dial to the setting boxed in silver and have students read the voltage produced by the solar panel. Tell students, “Voltage is represented by the letter V.” Record this number in the class notebook under letter a, and have students copy it into their notebook. Tell students, “Now that we have the current and the voltage, we can use our calculators to determine the power produced by the solar panel.” In the class notebook show students how to set up their equation ($P = I \times V$). Write the current value and units (Ex: 2.9 mA) in

the first blank, and the voltage value and units (Ex: 1.8 V) in the second blank. Place a calculator under the document camera, and show students how to input the operation into the calculator and solve for the power. Tell students, “We want to round our answer to the nearest tenth, which means we only want one number after the decimal.” Have students tell you the value of the power we should record, as well as the units for power (milliwatts), and then write the power value and units in the blank (Ex: 5.2 mW).

Tell students, “I will now measure the current and voltage of a battery pack that contains two round AAA batteries. These batteries produce more current than our solar panels so we will read the current in amps (A) instead of milliamps (mA). This will make our power be in unit of watts (W) instead of milliwatts (mW).” Hook up the battery pack to the multimeter and place the multimeter under the document camera. The process will be the same for determining the voltage as for the class solar panel. However, before you read the current you must switch the red lead to be in the 10A_{MAX} hole (pictured below) and turn the dial to 10 instead of the black boxed setting. Have students calculate the power of the round batteries; then have them share out the power and record it in the class notebook. Repeat this same process for the rectangular battery.

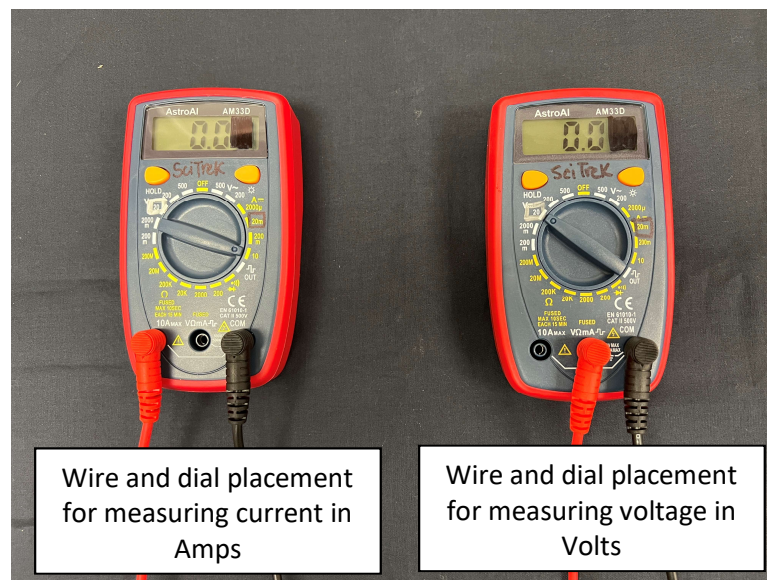

Tell students, “You will now calculate the power from your group’s solar panel on your own, and record your answer for letter d.” Have mentors calculate the power of the solar panel for their group to the nearest tenth, and check with their students to make sure they calculated the same value. They should also check to make sure students are setting up their calculations properly and including the appropriate units.

Have students remind you what happened when they hooked-up the red and blue LEDs to their solar panel. Possible student response: the red LED lit and the blue LED did not. Have students predict what will happen when you attach the blue LED to the round batteries, and allow a few students to share their ideas with the class. Take out the breadboard, place it under the document camera, and attach the round battery pack to the indicated ports (see example picture below). Take the blue LED and insert the legs into the corresponding ports. The red colored leg (long leg) should be placed into a port along the same row as the red wire. The black colored leg (short leg) should be placed into a port along the same row as the black wire (see example picture below). The LED should light up.

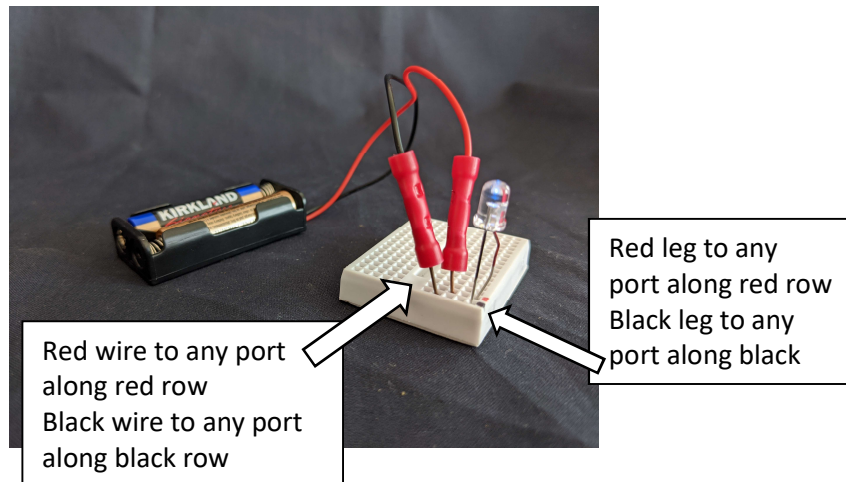

Have students predict what will happen when you attach the blue LED to the rectangular battery, and allow a few students to share out their ideas with the class. Take the LED out of the breadboard and detach the round battery pack. Attach the rectangular battery to the breadboard in the same way as the round battery pack (red wire to red port and black wire to black port). However, this time when you insert the LED put you hand between the class and the LED. The LED should blow immediately. Sometimes when the LED blows it ejects a piece of the plastic which will be stopped by your hand so that it does not hit students. Quickly take it out of the breadboard and hold it closely under the document camera so students can see inside of the LED.

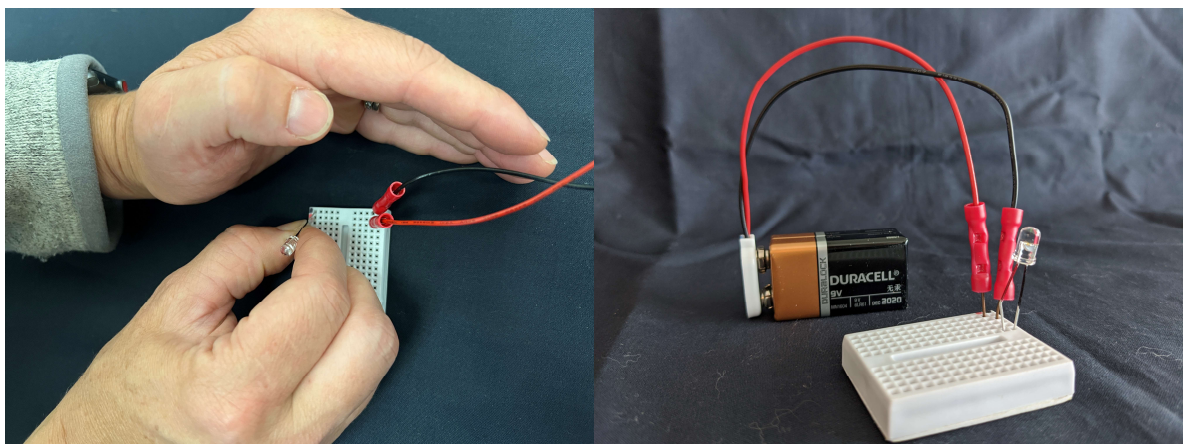

Ask students, “What happens when the blue LED is connected to the rectangular battery?” Possible student response: it blows up. Ask students, “Why do you think this happened?” Lead students to understand that too much power was applied to the LED, which caused it to blow up. Fill in questions 1 through 6 as a class and write the class consensus answer in the class notebook.

TECHNIQUE
Calculating Power

One way to measure the energy of our system over time is by calculating the **power** of the system. Power (P) can be found by multiplying the current (I) measured in milliamps (mA) and voltage (V) measured in volts (V) of the system together:

$$P = I \times V$$

For this experiment, power is calculated in units called **milliwatts** (mW).

Directions: Calculate the power produced by each system. Round your answer to the nearest tenth (Ex: 9.5 mW).

a) Class Solar Panel $I = 2.9 \text{ mA}$ $V = 1.8 \text{ V}$ $P = 2.9 \text{ mA} \times 1.8 \text{ V}$ $= 5.2 \text{ mW}$	b) Round Batteries $I = 3.8 \text{ A}$ $V = 3.1 \text{ V}$ $P = 3.8 \text{ A} \times 3.1 \text{ V}$ $= 11.8 \text{ W}$
c) Rectangular batteries $I = 2.4 \text{ A}$ $V = 8.6 \text{ V}$ $P = 2.4 \text{ A} \times 8.6 \text{ V}$ $= 20.6 \text{ W}$	d) Your Solar Panel $I = 5.2 \text{ mA}$ $V = 1.9 \text{ V}$ $P = 5.2 \text{ mA} \times 1.9 \text{ V}$ $= 9.9 \text{ mW}$

1. What does our experiment tell us about the red and blue LEDs?
They require a certain amount of power to work.
2. What happens when the blue LED is touched to the round batteries? *It lights up.*
3. What happens when the blue LED is touched to the rectangular battery? *It blows up.*
4. Why does this happen? *Too much power was applied.*
5. What does this tell us about lights/devices? *They operate under specific conditions and too much power can be harmful.*
6. How can we monitor the amount of power used by a device? *We can measure the current and voltage to calculate power usage.*

3

Tell students, “Now that we know how to calculate the energy per time, or the power, we can investigate the question: **What variables affect the power produced by a solar panel?**” Have students turn to the front cover of their notebooks as you turn to the front cover of the class notebook under the document camera and fill in the class question (What variables affect the power produced by a solar panel?)

Variable Discussion:

(5 minutes – Full Class – SciTrek Lead)

Lead students through the following questions, and explanations.

What does the word ‘variable’ mean to a scientist?

variables are the parts of the experiment you can change

Do you think there are multiple variables that will affect the power produced by the solar panel?

multiple variables might affect the power produced by the solar panel

Explain, this is why we will need to work as a class to answer the class question: “What variables affect the power produced by a solar panel?”

Tell the class, “You are going to think about variables, in the experiment, you could change, in order to help us answer the class question. In addition to generating variables, you should think about how and/or why, these variables might affect the outcome of the experiment.” Ask the class, “What do you think is a variable that might affect the power produced by the solar panel?” Then, have them tell you how and why they think that variable would affect the experiment. Probe them on how they would design an experiment to test whether this variable affected the power. Finally, have the students make a prediction of the results for the experiment they proposed. Remind students, “Predictions can be wrong, and we will not know the true answers until we carry out the experiment.”

Ex: Variable: amount shaded

Why might this variable affect the power produced by the solar panel? Solar panels that are less shaded will receive more light which would lead to more power being produced.

How would you test this variable? Place a cover over the solar panel at different shading amount and track the current and voltage being produced.

Prediction: The less shaded the panel, the larger the power produced.

Tell students, "You will now generate more variables and analyze them, in your groups."

Variables:

(9 minutes – Groups – SciTrek Mentors)

If there are less than 5 minutes left in session time. Do this as a class instead of in groups.

As a group, generate a variable and make a prediction about how it could affect the power produced by the solar panel. Encourage and challenge students to explain why they think their prediction is correct and how this variable could affect the power. If needed, you can write down a sentence frame for students to use. Repeat this process two more times, record these ideas on the notepad and have students copy them into their notebooks. If students have different predictions, they can write their own predictions in their notebooks. Next, students will individually generate additional variables, make predictions about how different values of these variables will affect the power produced by the solar panel, and record their ideas in their notebooks. Have students share these ideas with the group.

Prepare one student to share a variable and why they think it will affect the power produced by the solar panel during the class discussion.

VARIABLES	
Variable	How will changing this variable affect the power produced by a solar panel?
Panel Angle	Flatter panels (closer to 0°), will produce _____ power because _____.
Light Brightness	Brighter lights, will produce _____ power because _____.
Light Source	Natural light (like the sun), will produce _____ power because _____.
Choose your own!!	

2

VARIABLES	
Variable	How will changing this variable affect the power produced by a solar panel?
Panel Angle	Flatter panels (closer to 0°) will produce more power because the light will hit the panel more directly.
Light Brightness	Brighter lights will produce more power because the light will be more intense over the panel.
Light Source	Natural light (like the sun) will produce more power because we normally use sunlight on solar panels.
Temperature	Higher temperatures will produce more power because the solar panel may break down when it gets too hot.
Dirt Amount	More dirt on the solar panel will produce less power because the panel will have dirt blocking the light.

4

Wrap-Up:

(2 minutes – Full Class – SciTrek Lead)

Have one student from each group share a variable they generated, as well as how and why they think it will affect the power produced by the solar panel. Make sure, students tell you their predictions about how different values of that variable will affect the power.

Tell students, “Next session, you will design an experiment to answer the class question: What variables affect the power produced by a solar panel?”

Clean-Up:

1. Collect notebooks with attached nametags.
2. Make sure all calculators have their covers on and are placed back into the calculator box.
3. Place lamps, extension cords, and hairdryers back into their boxes.
4. Place all other materials into your group box and bring them back to UCSB.

Day 2: Question/Materials Page/Experimental Set-Up/Procedure/Results Table
Schedule:

Introduction (SciTrek Lead) – 14 minutes
 Question (SciTrek Mentors) – 7 minutes
 Materials Page (SciTrek Mentors) – 7 minutes
 Experimental Set-Up (SciTrek Mentors) – 8 minutes
 Procedure (SciTrek Mentors) – 18 minutes
 Results Table (SciTrek Mentors) – 3 minutes
 Wrap-Up (SciTrek Lead) – 3 minutes

*If there is extra time, do the claim, data, opinion extra practice (notebook, page 31).

Materials:

(3) Mentor Boxes:

- | | | |
|--|--|--|
| <input type="checkbox"/> Nametags | <input type="checkbox"/> Mentor lab coat | <input type="checkbox"/> (2) Pencils |
| <input type="checkbox"/> Notebooks | <input type="checkbox"/> (2) Materials pages (subgroup color & number indicated) | <input type="checkbox"/> (2) Red pens |
| <input type="checkbox"/> Mentor instructions | | <input type="checkbox"/> Paper notepad |

Lead Box:

- | | | |
|---|--|--|
| <input type="checkbox"/> (3) Blank nametags | <input type="checkbox"/> (2) Materials pages | <input type="checkbox"/> (2) Black pens |
| <input type="checkbox"/> (3) Extra notebooks | <input type="checkbox"/> Time card | <input type="checkbox"/> (3) Markers (orange, blue, green) |
| <input type="checkbox"/> Lead instructions | <input type="checkbox"/> (2) Pencils | <input type="checkbox"/> Paper notepad |
| <input type="checkbox"/> Solar Power picture packet | <input type="checkbox"/> (2) Red pens | |
| <input type="checkbox"/> Lead lab coat | <input type="checkbox"/> (2) Wet erase markers | |

Notebook Pages:

Experimental Considerations:

- You will only have access to the materials on the materials page.
- If you are not changing lamp height, the lamp height must be 14 cm.
- See materials page for restrictions on experimental design.

Changing Variable(s) (Independent Variable(s))

You will get to perform two experiments. For your first experiment, decide which variable(s) (max two) you would like to test. For each changing variable you select, discuss with your subgroup why you think that variable will affect the power produced by the solar panel.

Changing Variable 1: Panel Angle
 Discuss with your subgroup how you think **changing variable 1** will affect the power produced by the solar panel.

Changing Variable 2 (optional): Temperature
 Discuss with your subgroup how you think **changing variable 2** will affect the power produced by the solar panel.

QUESTION

Question our subgroup will investigate:

- If we change the panel angle and temperature,
insert each changing variable (independent variable)
 what will happen to the power produced by the solar
insert what you are calculating
panel?

SciTrek Member Approval: SL

Get a materials page from your volunteer and fill it out before moving onto the experimental set-up.

5

EXPERIMENTAL SET-UP

Write your changing variable(s) (Ex: panel angle) and the values (Ex: 45°) you will use for your trials under each solar panel.

A B C

Changing Variable(s):

- 1) Panel Angle : 30° 75° 45°
- 2) Temperature : RT 30°C 44°C

Controls (variables you will hold constant):
 Write your controls and the values you will use in all your trials (control/value, Ex: power source/solar panel).

Power Source / Solar Panel Light Height / 14 cm
 Shading Amount / 6/8

SciTrek Member Approval: SL

6

PROCEDURE

Procedure Note:
 Make sure to include all values of your changing variable(s) in the procedure. Ex: For a subgroup that decided to change panel angle one step would be: Place the panel at an angle of A) 30°, B) 45°, and C) 60°.

1. Set up lamp using spacing tool at 14 cm above panel.
2. Place shading tool on solar panel so it is 6/8 shaded.
3. Set panel angle to A) 30°, B) 75°, and C) 45°.
4. Place solar panel directly under lamp, and then turn lamp on.
5. Heat the solar panel to A) RT, B) 30°C, and C) 44°C.
6. Use multimeter to measure the current (mA) and voltage (V).
7. Calculate the power produced by the solar cell by
8. _____

SciTrek Member Approval: SL

7

RESULTS

Table

Fill out the table for each of your trials. For the variables that remain constant, write the value in Trial A. Then, draw an arrow through each box indicating the variable is a control. Remember to record measurements to the nearest tenth (Ex. 4.1 mA) and calculate power to the nearest tenth (Ex. 13.2 mW).

Variables	Trial A	Trial B	Trial C
Power Source:	Solar panel	→	
Panel Angle:	30°	75°	45°
Shading Amount:	6/8	→	
Temperature:	RT	30°C	44°C
Room Temp: 22°C			
Light Height:	14 cm	→	
Predictions	Trial A	Trial B	Trial C
Put an "S" in the trial that will give the smallest power and an "L" in the trial that will give the largest power.		S	L
Data and Calculations	Trial A	Trial B	Trial C
Measurements:	Current (mA):		
	Voltage (V):		
Calculations:	Power (mW): $P = I \times V$		

The independent variable(s) is(are) the changing variable(s) and the dependent variables are the current and voltage.

8

Preparation:

SciTrek Lead:

1. Make sure mentors are setting out notebooks in such a way that allows students within the same subgroup to work together.
2. Set up the document camera for the question (notebook, page 5), materials page (lead box), experimental set-up (notebook, page 6), and results table (picture packet, page 1).

SciTrek Mentors:

1. Set out notebooks/nametags to allow students in the same subgroup (same number on the front of their notebook) to work together.
2. Make sure you have two materials pages, each filled out with a subgroup number (1 or 2) and your group's color, to give to subgroups after they complete their question.
3. Have a red pen available to approve subgroups' questions, experimental set-ups, and procedures (notebook, pages 5-7).

Note: Set notebooks where students will sit during the module, even if another student is currently at that desk. If needed, students will move to these spots after the Introduction.

Introduction:

(12 minutes – Full Class – SciTrek Lead)

If students are not in their subgroups, tell them, "A notebook will be put on your desk, which is not your notebook and you should not move it. You will move to your notebook after the Introduction."

Ask students, "What did we do and learn during our last session?" Possible student response: we measured the current in milliamps and the voltage in volts produced by a solar panel. We learned if we multiply the current and the voltage you will get the power of the solar panel or the energy per time. If the power is too high or too low a device will not work. We also generated variables that might affect the power produced by the solar panel. Ask the class, "What is the class question we will be investigating?" Students should reply, "What variables affect the power produced by a solar panel?"

Tell students, "One way scientists answer questions is by performing experiments. Today, you will design an experiment to help answer the class question." Ask the class, "Do you think there are multiple variables that could affect the power produced by the solar panel?" Possible student response: there are probably multiple variables.

Explain to students, "Many times, when there is a broad question, like our class question, scientists break it down into smaller, more specific questions which small groups of scientists can investigate. The scientists then compile their work to answer the broader question. Therefore, each subgroup is going to generate a smaller question to investigate. Once we put all the subgroups' research together, we should be able to answer the class question."

Subgroups will first generate a question based on the changing variable(s) they plan to explore. They will then fill out their materials page, which will allow them to determine their experimental set-up. The experimental set-up will help them generate a procedure, or a set of steps to conduct an experiment. Go over the experimental considerations (notebook, page 5) with students so they understand the limitations in the experiments they can design.

Experimental Considerations:

1. You will only have access to the materials on the materials page.
2. If you are not changing lamp height, the lamp height must be 14 cm.
3. See the materials page for restrictions on experimental design.

Tell students, “We are now going to generate an example question/experimental set-up together. I will write it in the class notebook, so you will be able to refer back to it when you are completing the process yourselves.” Make sure students **do not** fill out the example question/experimental set-up in their notebooks, as they will be completing these pages for their own experiments in subgroups.

Tell students, “For the example experiment, the changing variable will be panel angle.” Note: As an alternative, you can pick shading amount as the changing variable but do not choose temperature. If you choose temperature as the changing variable, you will not be able to show them how to record room temperature. Then, write down the changing variable in the class notebook (notebook, page 5), under the document camera. Tell students, “When you are going through this process in your subgroups, you may select one or two changing variables.”

Show students how to insert the changing variable and what they plan to calculate, into the question frame to generate the question that will be investigated, “If we change the panel angle, what will happen to the power produced by a solar panel?”

Experimental Considerations:

1. You will only have access to the materials on the materials page.
2. If you are not changing lamp height, the lamp height must be 14 cm.
3. See materials page for restrictions on experimental design.

Changing Variable(s) (Independent Variable(s))

You will get to perform two experiments. For your first experiment, decide which variable(s) (max two) you would like to test. For each changing variable you select, discuss with your subgroup why you think that variable will affect the power produced by the solar panel.

Changing Variable 1: Panel Angle

Discuss with your subgroup how you think **changing variable 1** will affect the power produced by the solar panel.

Changing Variable 2 (optional): _____

Discuss with your subgroup how you think **changing variable 2** will affect the power produced by the solar panel.

QUESTION

Question our subgroup will investigate:

- If we change the panel angle _____, what will happen to the power produced by the solar panel _____?

SciTrek Member Approval: _____

Get a materials page from your volunteer and fill it out before moving onto the experimental set-up.

5

Tell students, “Once you have determined your question, and have approval, your mentor will give you a materials page for determining the values of your controls and changing variable(s).” Ask students, “What is a control?” Make sure, by the end of the conversation, students understand controls are variables that are held constant during an experiment. For example, if the shading was $\frac{1}{8}$ for all of the trials, then one of their controls would be shading amount. These controls, and control values, can be different from the original experiment they conducted on Day 1, but must remain constant throughout all the trials they do for this experiment.

Show students the materials page (lead box), and read the first step (*For each bolded word, underline if it is a control and circle if it is a changing variable.*). Then, have students tell you what to do for each bolded word. Read steps 2 and 3 on the materials page (*For variables that are controls, choose 1 value and write it in the first blank. For variables that are changing variables, choose 3 values and write the trial letter (A, B, C) under each value.*). Read the general materials to students, ask them if they need each one, and check the box when they say yes.

Go through the remaining items on the materials page. If a variable is a control, then choose (do not let students choose) a single value, such as the original value (Ex: $\frac{2}{8}$ for shading amount). When you get to temperature, tell students, "You can pick any temperature between 26°C and 44°C or you can pick room temperature. Since room temperature varies between 19°C and 26°C, if you want room temperature you will just write RT on the line and then you will measure the exact room temperature on the day of your experiment. Pick RT for the control values and write it on the line. Assign each control value to a student, and tell them, "You are in charge of remembering this control, and its value, to help when filling out the experimental set-up." For the variable that is the changing variable, allow students to select the values. Make sure to follow all restrictions listed (Ex: panel angle may only be 30° - 75°) Write the trial letter under each selected value. Ask students, "Do we want a narrow, or wide, range of values for the changing variable, and why?" Guide students through selecting a wide range of values for the changing variable. If they choose a value contrary to their proposed experimental design, question them on their reasoning. For example, if they said they wanted to use a wide range of panel angles and they picked 30°, 32°, and 34°, ask them, "Would the selected values allow us to best answer the question?" Allow them to change their values if needed. Assign the changing variable values to the students who chose them to remember for the experimental set up.

Color (circle one): Orange Blue Green
 Subgroup Number (circle one): 1 2

MATERIALS PAGE

You will only have access to the following materials.

- 1) For each bolded word, underline if it is a control and circle if it is a changing variable.
Ex control: Temperature, Ex changing variable: Panel Angle
- 2) For variables that are controls, choose 1 value and write it in the first blank.
- 3) For variables that are changing variables, choose 3 values and write the trial letter (A, B, C) under each value. Ex: $\frac{30^\circ}{A}$

General Materials:

<input checked="" type="checkbox"/> Solar panel	<input checked="" type="checkbox"/> Multimeter	<input checked="" type="checkbox"/> Ruler
<input checked="" type="checkbox"/> Solar panel holder	<input checked="" type="checkbox"/> Shading tool + 2 binder clips	<input checked="" type="checkbox"/> Protractor
<input checked="" type="checkbox"/> Lamp	<input checked="" type="checkbox"/> Hair dryer (if not at room temp)	<input checked="" type="checkbox"/> Calculator
<input checked="" type="checkbox"/> Infrared thermometer	<input checked="" type="checkbox"/> Spacing tool	

Panel Angle Choose any angle(s) between 30° and 75°. (original = 45°)

$\frac{30^\circ}{A}$ $\frac{75^\circ}{B}$ $\frac{45^\circ}{C}$

Shading Amount: Choose any fraction(s) from $\frac{0}{8}$ to $\frac{7}{8}$; $\frac{8}{8}$ can only be chosen if it is your changing variable. ($\frac{0}{8}$ = no shading; $\frac{8}{8}$ = fully shaded; original = $\frac{3}{8}$)

<input type="checkbox"/> $\frac{0}{8}$	<input type="checkbox"/> $\frac{1}{8}$	<input type="checkbox"/> $\frac{2}{8}$
<input type="checkbox"/> $\frac{3}{8}$	<input type="checkbox"/> $\frac{4}{8}$	<input type="checkbox"/> $\frac{5}{8}$
<input checked="" type="checkbox"/> $\frac{6}{8}$	<input type="checkbox"/> $\frac{7}{8}$	<input type="checkbox"/> $\frac{8}{8}$

Temperature: Choose any whole number temperature(s) between 26°C and 44°C. You may also choose room temperature (ranges from 19°C - 26°C). If you select this value, write "RT" on the line. You will record the numerical value of the room temperature on experiment day. (original = 30°C)

RT _____

Materials Page

EXPERIMENTAL SET-UP

Write your changing variable(s) (Ex: panel angle) and the values (Ex: 45°) you will use for your trials under each solar panel.

Changing Variable(s):

1) Panel Angle : 30° 75° _____

2) _____ : _____ _____ _____

Controls (variables you will hold constant):
Write your controls and the values you will use in all your trials (control/value, Ex: power source/solar panel).

Power Source / Solar Panel Temperature / RT
Shading Amount / 2/8 Light Height / 14 cm

SciTrek Member Approval: _____

6

Tell students, "Once you have completed your materials page, you will fill out your experimental set-up. First, you will fill out the information on the changing variable(s)." Ask students, "What is the changing variable for the example experiment, and what values did we select?" Then, fill in the values, for trials A

and B only. Tell students, “Second, you will fill in information about your controls.” Draw an additional control line under the existing control list. Ask students, “What is one of the controls, and its value, for the example experiment?” Show students how to record the control on the left side of the slash (Ex: panel angle), and the value of that control on the right side of the slash (Ex: 30°) by doing so in the class notebook. There are three possible variables to choose from on the materials page. If a subgroup changes two variables, they will be left with one control blank empty after inserting in the information from the materials page. Since all control blanks must be filled out, tell students, “You may need to generate an additional control that does not come from the materials page.” Lead students to realize this should be “light height/14 cm.”

Ask students, “Should everyone choose the same changing variable and why or why not?” Possible student response: no, because we will not learn as much about the class question. Tell students, “This means you should try to explore a changing variable you think few other subgroups are exploring. Once your subgroup has completed your experimental set-up, you should raise your hands and get it approved by your mentor.” Above is an example of what should be filled out for the experimental set-up in the class notebook. Note that several sections are left blank by the lead, but students will fill these in for their own notebooks.

Tell students, “After you finish your experimental set-up, you will write a procedure for your experiment that you will be able to follow next session. When writing a procedure, you should include all values of your controls, and changing variable(s), as well as what data you will be collecting and what you will calculate.” Show students the example procedure step on page 7 of their notebook (*Place the panel at an angle of A) 30°, B) 45°, and C) 60°*). Tell students, “Once your procedure is completed, you will get it approved by a mentor.”

Tell students, “After you write your procedure you will fill out your results table.” Put the filled-out results table (picture packet, page 1, below) under the document camera. **Note:** This is the results table for experiment 2, but it can be used to show students what to do with controls and changing variables. Tell students, “You should first underline controls, circle changing variables, and box information about data collection. For controls, you will write the control value in the *Trial A* box. Then, draw an arrow through the remaining trials’ boxes. For the changing variable(s), you will write the changing variable value in each box.” Show students both of these on the filled-out results table. Tell students, “Once you have filled out your results table, you will make predictions about which trial will produce the smallest and largest power. You will write an ‘S’ in the box of the trial you think will produce the smallest power, and an ‘L’ in the box of the trial you think will produce the largest power. If you think all trials will produce the same power, you will write ‘same’ over all boxes.”

RESULTS
Table

Check the box of your subgroup control and write your subgroup symbol on the line. Then, fill out the chart for each of your trials. For the variables that remain constant, write the value in Trial D and then draw an arrow through each box indicating the variable is a control. Remember to record data measurements to the nearest tenth (Ex. 4.1 mA), calculate power to the nearest tenth (Ex. 13.2 mW), and percentages to the nearest whole number (Ex. 75%).

Subgroup Control: Panel Angle Shading Amount Temperature Subgroup Symbol: △

Variables	Trial D	Trial E	Trial F	Trial G
<u>Power Source:</u>	1 solar panel	2 solar panel	3 solar panel	4 solar panel
<u>Panel Angle:</u>	50°	→		
<u>Shading:</u>	0/8	→		
<u>Temperature:</u>		→		
Room Temp: <u>22°C</u>	RT	→		
<u>Light Height:</u>	14 cm	→		
<u>Predictions</u>	Trial E	Trial F	Trial G	Trial H
Put an "S" in the trial that will give the smallest power and an "L" in the trial that will give the largest power.	L			S
<u>Data and Calculations</u>	Trial D	Trial E	Trial F	Trial G
Current (mA):	5.2 mA	6.0 mA	6.7 mA	7.7 mA
Voltage (V):	1.9 V	1.9 V	2.0 V	2.0 V
Percent CV: (get values from pg. 20)	25%	50%	75%	100%
Power (mW): $P = I \times V$	$5.2 \text{ mA} \times 1.9 \text{ V}$ = 9.9 mW	$6.0 \text{ mA} \times 1.9 \text{ V}$ = 11.4 mW	$6.7 \text{ mA} \times 2.0 \text{ V}$ = 13.4 mW	$7.7 \text{ mA} \times 2.0 \text{ V}$ = 15.4 mW

The independent variable is the changing variable and the dependent variables are the current and voltage.

Picture Packet, Page 1

Have students start the design process. Place the example question (notebook, page 5) under the document camera so students may refer to it as they design their experiments. As subgroups move onto their experimental set-ups, put the example experimental set-up (notebook, page 6) under the document camera.

Question:

(9 minutes – Subgroups – SciTrek Mentors)

Have subgroups decide what changing variable(s) they want to explore for their first experiment. Do not try and sway students in any particular direction when choosing their number of changing variables. If they only have one changing variable, do not encourage them to have more. If they have two changing variables, do not encourage them to have fewer. Students will analyze their data, and then perform an additional experiment to correct any mistakes they made on their first experiment.

After subgroups have decided on their changing variable(s), have them fill out their question. When you sign off on their question, give them a materials page with their subgroup color and number designated in the upper right-hand corner. An example filled-out question is shown below.

Experimental Considerations:

1. You will only have access to the materials on the materials page.
2. If you are not changing lamp height, the lamp height must be 14 cm.
3. See materials page for restrictions on experimental design.

Changing Variable(s) (Independent Variable(s))

You will get to perform two experiments. For your first experiment, decide which variable(s) (max two) you would like to test. For each changing variable you select, discuss with your subgroup why you think that variable will affect the power produced by the solar panel.

Changing Variable 1: Panel Angle
 Discuss with your subgroup how you think **changing variable 1** will affect the power produced by the solar panel.

Changing Variable 2 (optional): Temperature
 Discuss with your subgroup how you think **changing variable 2** will affect the power produced by the solar panel.

QUESTION

Question our subgroup will investigate:

- If we change the panel angle and temperature
insert each changing variable (independent variable)
 what will happen to the power produced by the solar
insert what you are calculating
panel _____ ?

SciTrek Member Approval: SL

Get a materials page from your volunteer and fill it out before moving onto the experimental set-up.

5

Materials Page:
 (7 minutes – Subgroups – SciTrek Mentors)

Have subgroups underline their control(s) and circle their changing variable(s) on the materials page. Then, have them use the materials page to choose the values for their control(s) and changing variable(s). For the changing variable(s) values, have students write the trial letter (A, B, or C) under the value they select. Ask students, “Why did you choose the values you did for your controls and changing variable(s)? Will these values make it easier or harder to answer your question?”

Make sure students have picked panel angles, shading amounts, and temperatures that are **within the limitations** given on the materials page. An example filled-out materials page is shown in the Experimental Set-Up section below.

Experimental Set-Up:
 (8 minutes – Subgroups – SciTrek Mentors)

Have subgroups use their materials page to fill in their experimental set-ups (notebook, page 6). For subgroups who have two changing variables, there will be one control blank that will not come from the materials page. For this control, students should write “light source/lamp.” When you sign off on their experimental set-ups, ensure all students within a subgroup have the same trial letters corresponding to the same changing variable values; then, collect the materials page and verify that it is filled out correctly and completely. Filling out the materials page is essential for students to obtain the correct materials for their experiments on Day 3. An example filled-out experimental set-up is shown below (right).

Color (circle one): Orange Blue Green
 Subgroup Number (circle one): 1 2

MATERIALS PAGE

You will only have access to the following materials.

- For each bolded word, underline if it is a control and circle if it is a changing variable.
 Ex control: Temperature, Ex changing variable: Panel Angle
- For variables that are controls, choose 1 value and write it in the first blank.
- For variables that are changing variables, choose 3 values and write the trial letter (A, B, C) under each value. Ex: $\frac{30^\circ}{A}$

General Materials:

<input checked="" type="checkbox"/> Solar panel	<input checked="" type="checkbox"/> Multimeter	<input checked="" type="checkbox"/> Ruler
<input checked="" type="checkbox"/> Solar panel holder	<input checked="" type="checkbox"/> Shading tool + 2 binder clips	<input checked="" type="checkbox"/> Protractor
<input checked="" type="checkbox"/> Lamp	<input checked="" type="checkbox"/> Hair dryer (if not at room temp)	<input checked="" type="checkbox"/> Calculator
<input checked="" type="checkbox"/> Infrared thermometer	<input checked="" type="checkbox"/> Spacing tool	

Panel Angle: Choose any angle(s) between 30° and 75°. (original = 45°)

30° 75° 45°
 A B C

Shading Amount: Choose any fraction(s) from $\frac{0}{8}$ to $\frac{7}{8}$. $\frac{0}{8}$ can only be chosen if it is your changing variable. ($\frac{0}{8}$ = no shading, $\frac{8}{8}$ = fully shaded; original = $\frac{2}{8}$)

<input type="checkbox"/> $\frac{0}{8}$	<input type="checkbox"/> $\frac{1}{8}$	<input type="checkbox"/> $\frac{2}{8}$
<input type="checkbox"/> $\frac{3}{8}$	<input type="checkbox"/> $\frac{4}{8}$	<input type="checkbox"/> $\frac{5}{8}$
<input checked="" type="checkbox"/> $\frac{6}{8}$	<input type="checkbox"/> $\frac{7}{8}$	<input type="checkbox"/> $\frac{8}{8}$

Temperature: Choose any whole number temperature(s) between 26°C and 44°C. You may also choose room temperature (ranges from 19°C - 26°C). If you select this value, write "RT" on the line. You will record the numerical value of the room temperature on experiment day. (original = 30°C)

RT 30°C 44°C
 A B C

Materials Page

EXPERIMENTAL SET-UP

Write your changing variable(s) (Ex: panel angle) and the values (Ex: 45°) you will use for your trials under each solar panel.

A B C

Changing Variable(s):

- Panel Angle : 30° 75° 45°
- Temperature : RT 30°C 44°C

Controls (variables you will hold constant):
 Write your controls and the values you will use in all your trials (control/value, Ex: power source/solar panel).

Power Source / Solar Panel Light Height / 14 cm

Shading Amount / 6/8

SciTrek Member Approval: SL

6

Procedure:
 (18 minutes – Subgroups – SciTrek Mentors)

After each subgroup has filled out their experimental set-up, they can start on their procedure (notebook, page 7). Make sure students within the same subgroup are collaborating to write their procedure. Keep procedures as brief as possible, while still conveying the pertinent information (control values, changing variable values, the data they will collect, and what they will calculate) about the experiment. An example step for a subgroup with panel angle as a changing variable would be: "Place the panel at an angle of A) 30°, B) 45°, and C) 60°." Some subgroups may struggle with writing procedures. You can have these subgroups dictate each step while you transcribe them onto a notepad found in your group box. Give this sheet to students to copy into their notebooks. Once students have finished, they should raise their hands and get their procedures approved by their mentor. An example filled out procedure is shown below (left).

Note: 6th grade students are more independent, therefore, students in each subgroup may vary the wording in their procedures. This is fine as long as the steps are in the same order, and the correct values are included in the same steps.

PROCEDURE

Procedure Note:
Make sure to include all values of your changing variable(s) in the procedure. Ex: For a subgroup that decided to change panel angle one step would be: Place the panel at an angle of A) 30°, B) 45°, and C) 60°.

1. Set up lamp using spacing tool at 14 cm above panel.
2. _____
Place shading tool on solar panel so it is 6/8 shaded.
3. Set panel angle to A) 30°, B) 75°, and C) 45°.
4. _____
Place solar panel directly under lamp, and then turn lamp on.
5. Heat the solar panel to A) RT, B) 30°C, and C) 44°C.
6. _____
Use multimeter to measure the current (mA) and voltage (V).
7. _____
Calculate the power produced by the solar cell by
8. _____

SciTrek Member Approval: SL

7

RESULTS Table

Fill out the table for each of your trials. For the variables that remain constant, write the value in Trial A. Then, draw an arrow through each box indicating the variable is a control. Remember to record measurements to the nearest tenth (Ex. 4.1 mA) and calculate power to the nearest tenth (Ex. 13.2 mW).

Variables	Trial A	Trial B	Trial C
Power Source:	Solar panel →		
Panel Angle:	30°	75°	45°
Shading Amount:	6/8 →		
Temperature:	RT	30°C	44°C
Room Temp: 22°C			
Light Height:	14 cm →		
Predictions	Trial A	Trial B	Trial C
Put an "S" in the trial that will give the smallest power and an "L" in the trial that will give the largest power.		S	L
Data and Calculations	Trial A	Trial B	Trial C
Measurements:			
Current (mA):			
Voltage (V):			
Calculations:			
Power (mW): $P = I \times V$			

The independent variable(s) is(are) the changing variable(s) and the dependent variables are the current and voltage.

8

Results Table:

(3 minutes – Subgroups – SciTrek Mentors)

Have students underline the variables that are controls, circle the variable(s) that is/are their changing variable(s), and box information about data collection. When writing the values make sure for controls, they only write the value of the control in the *Trial A* box, then, draw an arrow through the remaining trials' boxes. For the changing variable(s), they should write the values in each trial's corresponding box.

When students have finished, have them make predictions about the power produced by the solar panel. Have them write an "S" in the box of the trial they think will produce the smallest power and an "L" in the box of the trial they think will produce the largest power. They will leave two of the boxes empty. If they think all trials will produce the same power, have them write "same" over all of the boxes. It is okay if the students in a subgroup have different predictions. An example filled-out results table is shown above (right).

Wrap-Up:

(3 minutes – Full Class – SciTrek Lead)

Have one student from each subgroup share what question they will investigate.

Then, as a class complete the extra practice (notebook, page 31) where students determine if statements are claim, data, or opinion. Doing this extra practice will make it easier for students to write conclusions next session.

Tell students, "Next session, you will start your experiments. All of your experiments will help us answer the class question: What variables affect the power produced by a solar panel?"

Clean-Up:

1. Collect notebooks with attached nametags.
2. Place materials into your group box and bring them back to UCSB.

Day 3: Experiment/Analysis Activity/Conclusion
Schedule:

Introduction (SciTrek Lead) – 3 minutes
 Experiment (SciTrek Mentors) – 20 minutes
 Analysis Activity (SciTrek Lead) – 30 minutes
 Conclusion (SciTrek Mentors) – 6 minutes
 Wrap-Up (SciTrek Lead) – 1 minute

Materials:

(3) Mentor Boxes:

- | | | |
|---|---|---|
| <input type="checkbox"/> Nametags | <input type="checkbox"/> Picture of experimental set-up | <input type="checkbox"/> (2) Red pens |
| <input type="checkbox"/> Notebooks | <input type="checkbox"/> Mentor lab coat | <input type="checkbox"/> Paper notepad |
| <input type="checkbox"/> Mentor instructions | <input type="checkbox"/> (2) Pencils | <input type="checkbox"/> (2) Solar panel holders |
| (2) Ziploc bags (gallon size), labeled (with subgroup number), each with the following: | | |
| <input type="checkbox"/> Filled-out materials page | <input type="checkbox"/> Solar panel | <input type="checkbox"/> Spacing tool |
| <input type="checkbox"/> Ruler | <input type="checkbox"/> IR thermometer | <input type="checkbox"/> Shading tool |
| <input type="checkbox"/> Protractor | <input type="checkbox"/> Multimeter | <input type="checkbox"/> (2) Binder clips (15 mm) |

Other Supplies:

- | | | |
|--|---|---|
| <input type="checkbox"/> (2) Boxes of (4) lamps with (4) extension cords | <input type="checkbox"/> Calculator box | <input type="checkbox"/> Box with (6) hair dryers |
|--|---|---|

Lead Box:

- | | | |
|---|--|---|
| <input type="checkbox"/> (3) Extra notebooks | <input type="checkbox"/> (2) Pencils | <input type="checkbox"/> Solar panel |
| <input type="checkbox"/> Lead instructions | <input type="checkbox"/> (2) Red pens | <input type="checkbox"/> Solar panel $\frac{6}{8}$ shaded in holder |
| <input type="checkbox"/> Solar Power picture packet | <input type="checkbox"/> (2) Wet erase markers | <input type="checkbox"/> IR thermometer |
| <input type="checkbox"/> Picture of experimental set-up | <input type="checkbox"/> (2) Black pens | <input type="checkbox"/> (2) Multimeters |
| <input type="checkbox"/> Lead lab coat | <input type="checkbox"/> Paper notepad | <input type="checkbox"/> Spacing tool |
| <input type="checkbox"/> Time card | <input type="checkbox"/> (2) Rulers | <input type="checkbox"/> Shading tool |
| | <input type="checkbox"/> (3) Protractors | <input type="checkbox"/> (2) Binder clips (15 mm) |

Notebook Pages:

RESULTS
Table

Fill out the table for each of your trials. For the variables that remain constant, write the value in Trial A. Then, draw an arrow through each box indicating the variable is a control. Remember to record measurements to the nearest tenth (Ex. 4.1 mA) and calculate power to the nearest tenth (Ex. 13.2 mW).

Variables	Trial A	Trial B	Trial C
Power Source:	Solar panel		
Panel Angle:	30°	75°	45°
Shading Amount:	6/8		
Temperature:			
Room Temp: 22°C	RT	30°C	44°C
Light Height:	14 cm		
Predictions	Trial A	Trial B	Trial C
Put an "S" in the trial that will give the smallest power and an "L" in the trial that will give the largest power.		S	L
Data and Calculations	Trial A	Trial B	Trial C
Measurements:			
Current (mA):	6.7 mA	0.7 mA	5.3 mA
Voltage (V):	2.0 V	1.6 V	2.0 V
Calculations:			
Power (mW): $P = I \times V$	6.7 mA x 2.0 V = 13.4 mW	0.7 mA x 1.6 V = 1.1 mW	5.3 mA x 2.0 V = 10.6 mW

The independent variable(s) is(are) the changing variable(s) and the dependent variables are the current and voltage.

8

SCIENTIFIC PRACTICES
Analyzing & Interpreting Data

1. Directions: Fill in the missing definitions.

- Conclusion:** A claim supported by data
- Claim:** A statement that can be tested. The explanation of the data, the first part of a conclusion.
 - Ex: Increased amounts of fertilizer runoff in lakes kills wildlife.
 - A claim in a scientific experiment often includes the changing variable.
- Data:** Evidence collected from experiment(s) (measurements or observations), the second part of a conclusion.
 - Ex: We observed that in lakes with large amounts of fertilizer runoff, there were no living organisms while in lakes with little fertilizer runoff, there were many living organisms.
 - Data in a scientific experiment includes measurements or observations.
 - Data statements also often include values of the changing variable.

2. Directions: On the results tables and conclusions below, underline control(s), circle changing variable(s) and box information about data collection. Then, decide if the possible conclusion is correct or not.

a)

Variables	Trial A	Trial B	Trial C	Trial D
Power Plant Type:	Coal			
Substance Amount:	3,000 Mg			
Number of Generators:	2	3	4	5
Water Amount:	4,500 L			
Number of Workers:	10			
Data	Trial A	Trial B	Trial C	Trial D
Power:	103 MW	126 MW	135 MW	150 MW
Other:	Air around plant is dark brown	Air around plant is dark brown	Air around plant is dark brown	Air around plant is dark brown

Possible Conclusion: The higher the number of generators, the greater the power produced, because when 2 generators were used 103 MW of power were produced, and when 5 generators were used 150 MW of power were produced.

Is this a correct conclusion? YES NO I DON'T KNOW

If NO, what is wrong with the conclusion? _____

9

SCIENTIFIC PRACTICES
Analyzing & Interpreting Data

b)

Variables	Trial A	Trial B	Trial C	Trial D
Power Plant Type:	Natural Gas			
Substance Amount:	3,200 Mg			
Number of Generators:	3			
Water Amount:	4,200 L			
Number of Workers:	8	10	12	14
Data	Trial A	Trial B	Trial C	Trial D
Power:	140 MW	139 MW	140 MW	141 MW
Other:	Air around plant is clear	Air around plant is clear	Air around plant is clear	Air around plant is clear

of workers

Possible Conclusion: The more people working at the power plant, the more power produce, because when 3 people were working 140 MW of power were produced, and when 14 people were working 141 MW of power were produced.

Is this a correct conclusion? YES NO I DON'T KNOW

If NO, what is wrong with the conclusion? Incorrect claim

c)

Variables	Trial A	Trial B	Trial C	Trial D
Power Plant Type:	Coal			
Substance Amount:	2,700 Mg	3,100 Mg	3,600 Mg	4,200 Mg
Number of Generators:	3			
Water Amount:	4,500 L			
Number of Workers:	10			
Data	Trial A	Trial B	Trial C	Trial D
Power:	131 MW	140 MW	147 MW	155 MW
Other:	Air around plant is light brown	Air around plant is brown	Air around plant is brown	Air around plant is dark brown

Substance Amount

Possible Conclusion: The greater the amount of coal burned in the power plant, the more polluted the air, because we observed when 2,700 Mg of coal were burned, the air was light brown and when 4,200 Mg of coal were burned, the air was dark brown.

Is this a correct conclusion? YES NO I DON'T KNOW

If NO, what is wrong with the conclusion? _____

10

SCIENTIFIC PRACTICES
Analyzing & Interpreting Data

d)

Variables	Trial A	Trial B	Trial C	Trial D
Power Plant Type:	Natural Gas			
Substance Amount:	3,100 Mg			
Number of Generators:	3			
Water Amount:	4,200 L	4,400 L	4,600 L	4,800 L
Number of Workers:	10			
Data	Trial A	Trial B	Trial C	Trial D
Power:	155 MW	147 MW	140 MW	128 MW
Other:	Air around plant is clear	Air around plant is clear	Air around plant is clear	Air around plant is clear

Possible Conclusion: When 4,200 of water were used 155 MW of power were produced, and when 4,800 of water were used 128 MW of power were produced, because the greater the water amount, the smaller the amount of power produced.

Is this a correct conclusion? YES NO I DON'T KNOW

If NO, what is wrong with the conclusion? Claim and data switched

e)

Variables	Trial A	Trial B	Trial C	Trial D
Power Plant Type:	Coal			
Substance Amount:	2,800 Mg	3,200 Mg	3,600 Mg	4,000 Mg
Number of Generators:	3			
Water Amount:	4,000 L	4,200 L	4,500 L	4,700 L
Number of Workers:	8			
Data	Trial A	Trial B	Trial C	Trial D
Power:	130 MW	139 MW	145 MW	155 MW
Other:	Air around plant is brown	Air around plant is brown	Air around plant is brown	Air around plant is brown

Possible Conclusion: The greater the water amount used in the power plant, the more power produced, because when 4,000 of water were used 130 MW of power were produced, and when 4,700 of water were used 155 MW of power were produced.

Is this a correct conclusion? YES NO I DON'T KNOW

If NO, what is wrong with the conclusion? More than 1 changing variable

3. How many changing variables can you have in order to make a conclusion? 1

11

CONCLUSION

Making a Conclusion from Your Data

How many changing variables did you have in your experiment? 1

Can you make a conclusion from your data? YES NO

IF NO

Why? _____

IF YES

We can conclude as the panel angle gets smaller
(closer to 30°), more power is produced by
the solar panel,
because when the panel angle was 40°,
11.6 mW of power were produced and
when the panel angle was 75°,
3.2 mW of power were produced.

SciTrek Member Approval: SL

12

Preparation:

SciTrek Lead:

1. Make sure mentors are setting out notebooks.
2. Make sure mentors are setting up for the experiment.
3. Set up the document camera for the Introduction (picture packet, page 2) and analysis activity (notebook, pages 9-11).
4. Have a solar panel, solar panel holder, spacing tool, shading tool, multimeter, thermometer, hair dryer, and lamp available to show students during the Introduction.

SciTrek Mentors:

1. Set out notebooks/nametags.
2. Plug lamps in, one for each subgroup, with enough cord to be able to set where they will work, if needed use an extension cord.
3. Put solar panel holders, calculators, and bags with supplies, next to the lamps.
4. Have a red pen available to approve students' conclusions (notebook, pages 12).

Note: Set notebooks where students will sit during the module, even if another student is currently at that desk. If needed, students will move to these spots after the Introduction.

Introduction:

(3 minutes – Full Class – SciTrek Lead)

If students are not in their subgroups, tell them, “A notebook will be put on your desk, which is not your notebook and you should not move it. You will move to your notebook after the Introduction.”

Ask the class, “What is the class question we are investigating?” Students should reply, “What variables affect the power produced by a solar panel?” Ask students, “What is power and how do we calculate it?” Possible student response: power is the energy per time and is calculated by multiplying the current and voltage. Ask students, “What units will we measure current and voltage in?” Students should reply, “milliamps (mA) and volts (V).” Ask students, “What units will power be in?” Students should reply, “Milliwatts (mW).” Tell students, “Today, you will conduct your experiments to answer this question. “

Place a set of experimental supplies under the document camera (solar panel, solar panel holder, spacing tool, shading tool, multimeter, thermometer, hair dryer, and lamp). Tell students, “I will remind you how to set up the solar panel and demonstrate how to collect the data for this experiment.” Connect the multimeter to the solar panel while reminding students that wire of the same color should be connected to each other (red wire to red wire and black wire to black wire) and the two colors of wires cannot touch. Next, tell students, “If you are shading your solar panel, the shading amount increases from the bottom of the solar panel to the top of the solar panel.” Demonstrate on the example solar panel where $\frac{1}{8}$ shading and $\frac{7}{8}$ shading would be.

Place the solar panel into the holder. Show students how to insert the spacing tool between the lamp and the panel (while the panel is at 0°) to set the correct light distance. Tell students, “Now the lamp is at the correct placement, we can remove the solar panel set-up from under the lamp to make it easier to set the panel angle.” Ask students, “What tool should we use to help us measure the panel angle?” Pull out the protractor and show students where to place it on the solar panel holder. Remind them when measuring the angle of the panel, they will use the clear scale on the protractor. Turn the picture packet to page 2 and place it under the document camera (below). Tell students, “For this experiment, the scientists were trying to have the angle at 45°. Therefore, while looking directly at the protractor you will move the solar panel until the angle of the solar panel matches the angle of the swing arm. You can then put the solar panel directly under the lamp without changing the lamp height.”

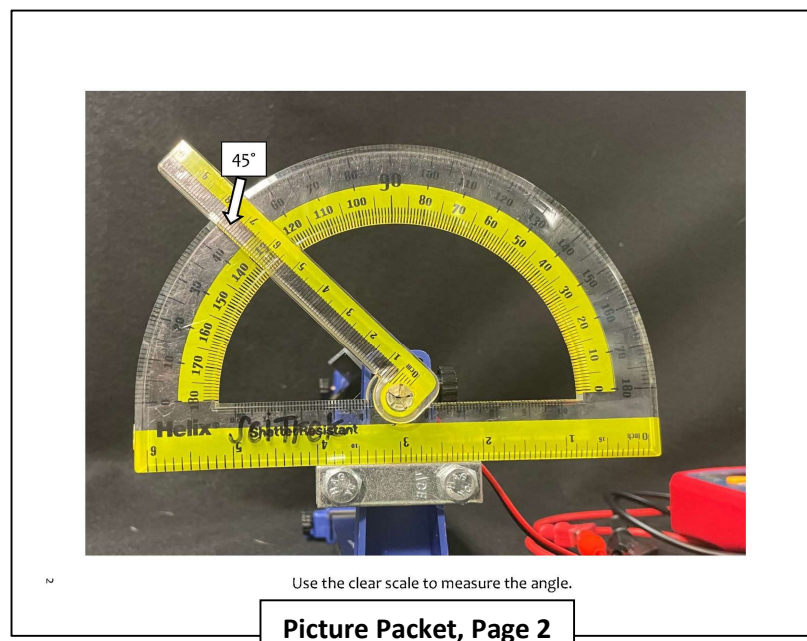

Tell students, “When you record your data, you will make three measurements: the room temperature, the current, and the voltage.” Show students where they will record these three things on the results table (notebook, page 8). They should use the thermometer to take the temperature of the room before starting their experimental trials. On the solar panel set up under the document camera, point to the silver dot in the middle of the solar panel. Tell students, “First, you need to hold the thermometer 90° from the panel. You should then point the thermometer at the silver dot in the center of the solar panel when taking the temperature, just like I am demonstrating now. If your panel is shaded more than $\frac{4}{8}$, you will need to point your thermometer at the correct dot, as indicated on the shading tool.” Place the shading tool on the solar panel at $\frac{7}{8}$ shaded and demonstrate how to take the temperature at the correct dot. An example picture is shown below. Tell students, “Because there is a laser in the thermometer that could hurt peoples’ eye, if you point the thermometer at anything other than the solar panel set up you will lose the right to use the thermometer.”

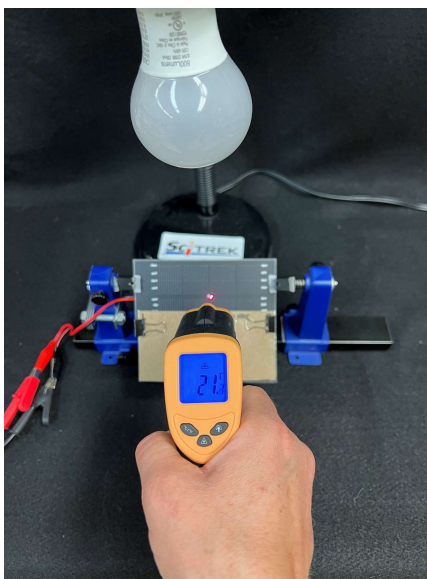

Tell students, “During the experiment there will be different roles for subgroup members to have. These roles are 1) operate the thermometer 2) operate the hairdryer, 3) read the multimeter, and 4) record the measurements. Between trials you should rotate roles. If a subgroup member did not have a role during the last trial, they get to rotate into whatever job they want. During the experiment you will get your panel to the appropriate temperature, I will tell you how to do this in a minute, then the person reading the multimeter should read out the current, which can be seen when the multimeter is turned to the setting boxed in black, then immediately twist the dial to the silver boxed setting to call out the voltage. While this is done the recorder should write down the measurements so everyone can copy them down after the trial.” Under the document camera, show the students how to flip between the current and voltage settings.

Next, tell students, “If you need to heat the solar panel, the person operating the thermometer should hold the thermometer about 6 inches from the panel at a 90° angle and take the initial temperature. Pull the thermometer away and allow the person with the hair dryer to begin to heat the solar panel for ~10 s making sure to sweep the hair dryer back and forth across the solar panel. After which, the temperature reader should take the temperature again. This process should be repeated until you are about 2°C above your goal temperature. Then, stop the hair dryer and allow the panel to cool until you reach your goal temperature. At the goal temperature, the thermometer reader should tell the multimeter reader to call out the current and voltage.” (**Note:** You do not need to turn on the hair dryer for this demonstration, just show the students the motion.) Tell students, “If temperature is a changing variable and you are doing a

room temperature trial do this trial first, regardless of trial letter. After which, do the hottest temperature and work down to the coolest temperature.

Tell students, “Once you have completed your trials, you should calculate the power produced by each solar panel (to the nearest tenth).” Have students remind you how they will calculate the power. Tell students, “You will now start your experiments. You will only have 20 minutes to collect your data, record it, and calculate the power so make sure you are working efficiently.”

Experiment:

(20 minutes – Subgroups – SciTrek Mentors)

Give students their requested materials. If students are missing any of their experimental materials, the lead box has extra materials. Have your subgroups show you their first set-up so you can approve it before moving on. Verify they have the correct angle of their solar panel and are using the clear scale of the protractor. If you have a subgroup using a temperature other than room temperature, stay and observe their first trial to make sure it runs smoothly. If temperature is a control, the subgroup should heat their panel to 2°C above their goal temperature, and allow the panel to cool before recording the current and voltage. If temperature is the changing variable and they have a room temperature trial, have them do the room temperature trial first. Then they should heat the solar panel to the maximum temperature and take the current and voltage readings as the panel cools down. Make sure students have assigned themselves roles (thermometer reader, hair dryer operator, multimeter reader, or recorder) and know to rotate those roles between trials. Remind subgroups they will read the current from the setting boxed in black on the multimeter, and the voltage from the setting boxed in silver.

Students should record the current and voltage during each trial, but have them wait until they have finished their entire experiment to calculate the powers for each trial.

Students will only be given 20 minutes for their experiments. After the 20 minutes are up, students will move onto the next activity even if they did not fully complete their experiment. If your group has things under control, help other subgroups. An example filled-out results table is shown below.

RESULTS
Table

Fill out the table for each of your trials. For the variables that remain constant, write the value in Trial A. Then, draw an arrow through each box indicating the variable is a control. Remember to record measurements to the nearest tenth (Ex. 4.1 mA) and calculate power to the nearest tenth (Ex. 13.2 mW).

Variables	Trial A	Trial B	Trial C
Power Source:	Solar panel →		
Panel Angle:	30°	75°	45°
Shading Amount:	6/8 →		
Temperature:	RT	30°C	44°C
Room Temp: 22°C			
Light Height:	14 cm →		
Predictions	Trial A	Trial B	Trial C
Put an "S" in the trial that will give the smallest power and an "L" in the trial that will give the largest power.		S	L
Data and Calculations	Trial A	Trial B	Trial C
Measurements:			
Current (mA):	6.7 mA	0.7 mA	5.3 mA
Voltage (V):	2.0 V	1.6 V	2.0 V
Calculations:			
Power (mW): $P = I \times V$	6.7 mA × 2.0 V = 13.4 mW	0.7 mA × 1.6 V = 1.1 mW	5.3 mA × 2.0 V = 10.6 mW

The independent variable(s) is(are) the changing variable(s) and the dependent variables are the current and voltage.

8

Analysis Activity:

(30 minutes – Full Class – SciTrek Lead)

Note: It is important to start the analysis activity at least 25 minutes before the end of the session.

Have students turn to page 9 in their notebooks while you turn to page 9 in the class notebook, displaying it under the document camera. Tell students, “Before you analyze your results and draw a conclusion, it is important that you recognize and understand other scientists’ conclusions.”

Ask the class, “What is a conclusion?” After listening to the students’ answers, make sure they understand a conclusion is a **claim supported by data**. Write this definition on page 9 of the class notebook for students to copy.

Tell students, “In order to make a conclusion, we need to make sure we understand the difference between a claim and data.” Read the definition of a claim (*A statement that can be tested. The explanation of the data, the first part of a conclusion*).

Then, read the example, *Increased amounts of fertilizer runoff in lakes kills wildlife*. Ask a student, “How could you test this claim?” Possible student response: find lakes with different amounts of fertilizer being poured into them, and observe the amount of life in the lake.” Then, ask another student, “Can you identify what the changing variable would be in that experiment?” Lead students to notice the changing variable (fertilizer runoff amount) was included in the claim, and circle *amounts of fertilizer runoff* in the example. Read the sentence frame to students, *A claim in a scientific experiment often includes the _____*. Ask students, “What should we write in the blank?” They should reply, “Changing variable.”

Next, read the definition of data (*Evidence collected from experiment(s) (measurements or observations), the second part of a conclusion*). Then, read the example, *we observed that in lakes with large amounts of fertilizer runoff, there were no living organisms, while in lakes with a little fertilizer runoff, there were many living organisms*. **Note:** The example data supports the example claim, therefore, a conclusion can

be formed by combining the two statements. This conclusion would be: Increased amounts of fertilizer runoff in lakes kills wildlife, because we observed that in lakes with large amounts of fertilizer runoff there were no living organisms, while in lakes with a little fertilizer runoff there were many living organisms. Tell students, “There are two forms of data collection, measurements and observations. If measurements were collected for data, then numerical values should be in the data statement. If observations were collected for data, then words such as ‘*observed*’ or ‘*recorded*’ should be in the data statement to allow you to know that an experiment was performed.” Read the first sentence frame to students, *Data in a scientific experiment includes _____ or _____*. Ask students, “What should we write in the blanks?” Students should reply, “Measurements and observations.” Ask students, “In our example data statement, what was the method of data collection and how do you know?” Possible student response: the method of data collection was observations, because the words “we observed” are in the statement. Ask students, “What data were these scientists observing?” Possible student response: the scientists were observing the amounts of living organisms in the lakes, specifically if there were *no living organisms* or *many living organisms*. Ask students, “What changed between the two lakes which caused them to have different amounts of living organisms?” Possible student response: the lakes had different amounts of fertilizer runoff. Lead students to understand that *large amounts* and *a little* are values of the changing variable. Have students circle the values of the changing variable, and box the observations, in the data statement. Read the second sentence frame to students. *Data statements also often include values of the _____*. Ask students, “What should we write in the blank?” Students should reply, “Changing variable.”

Read the directions to part 2 aloud to the class (*On the results tables and conclusions below, underline control(s), circle changing variable(s), and box information about data collection. Then, decide if the possible conclusion is correct or not.*).

For each question, first have student annotate the results table using the process below. Second, read the conclusion aloud to students and have them annotate the conclusion using the process below. Third use the flow chart below to analyze the conclusion as a class.

For annotating the tables, do parts *a* and *b* as a class; then, take the notebook out from under the document camera and have students try to do parts *c*, *d*, and *e* on their own, while you fill them out off to the side. After the students have finished working on it independently, have them check their work against yours.

For annotating the conclusions annotate them as a class.

Use the following flow chart as a guide for leading students through analyzing each conclusion. Examples of how this flow chart was used for conclusions *a-e*, along with possible student answers, can be seen after the notebook pages 9-11 below.

Flow Chart for Analyzing Conclusions:

What type of statement is before the ‘because,’ and how do you know?

If the statement is *data* (contains measurements or observations)

- Is this a correct conclusion? (No)
- What is wrong with the conclusion? (Claim and data switched)
- Move onto next conclusion

If the statement is a *claim* (can be tested)

- What is the changing variable in this claim?
- Is this a changing variable in this experiment? (Yes)
- Is the claim consistent with the results table?

If No

- Is this a correct conclusion? (No)
- What is wrong with the conclusion? (Incorrect claim)
- Move onto next conclusion

If Yes and *one changing variable*

- What type of statement is after the 'because,' and how do you know? (Data, because it contains measurements or observations.)
- Is the data consistent with the results table? (Yes)
- Is this a correct conclusion? (Yes)
- Move onto next conclusion.

If Yes and *two changing variables*

- What type of statement is after the 'because,' and how do you know? (Data, because it contains measurements or observations)
- Is the data consistent with the results table? (Yes)
- Is this a fair conclusion? (No, because the change could be due to the other changing variable.)
- Is this a correct conclusion? (No)
- What is wrong with the conclusion? (More than one changing variable)

SCIENTIFIC PRACTICES
Analyzing & Interpreting Data

1. Directions: Fill in the missing definitions.

- **Conclusion:** A claim supported by data
- **Claim:** A statement that can be tested. The explanation of the data, the first part of a conclusion.
 - Ex: Increased amounts of fertilizer runoff in lakes kills wildlife.
 - A claim in a scientific experiment often includes the changing variable.
- **Data:** Evidence collected from experiment(s) (measurements or observations), the second part of a conclusion.
 - Ex: We observed that in lakes with large amounts of fertilizer runoff, there were no living organisms while in lakes with little fertilizer runoff, there were many living organisms.
 - Data in a scientific experiment includes measurements or observations.
 - Data statements also often include values of the changing variable.

2. Directions: On the results tables and conclusions below, underline control(s), circle changing variable(s) and box information about data collection. Then, decide if the possible conclusion is correct or not.

a)

Variables	Trial A	Trial B	Trial C	Trial D
Power Plant Type:	Coal			
Substance Amount:	3,000 Mg			
<u>Number of Generators:</u>	2	3	4	5
Water Amount:	4,500 L			
Number of Workers:	10			
Data				
	Trial A	Trial B	Trial C	Trial D
Power:	103 MW	126 MW	135 MW	150 MW
Other:	Air around plant is dark brown	Air around plant is dark brown	Air around plant is dark brown	Air around plant is dark brown

Possible Conclusion: The higher the number of generators, the greater the power produced, because when 3 generators were used 103 MW of power were produced, and when 5 generators were used 150 MW of power were produced.

Is this a correct conclusion? YES NO I DON'T KNOW

If NO, what is wrong with the conclusion? _____

9

SCIENTIFIC PRACTICES
Analyzing & Interpreting Data

b)

Variables	Trial A	Trial B	Trial C	Trial D
Power Plant Type:	Natural Gas			
Substance Amount:	3,200 Mg			
Number of Generators:	3			
Water Amount:	4,200 L			
<u>Number of Workers:</u>	8	10	12	14
Data				
	Trial A	Trial B	Trial C	Trial D
Power:	140 MW	139 MW	140 MW	141 MW
Other:	Air around plant is clear	Air around plant is clear	Air around plant is clear	Air around plant is clear

Possible Conclusion: The more people working at the power plant, the more power produced, because when 9 people were working 140 MW of power were produced, and when 9 people were working 141 MW of power were produced.

Is this a correct conclusion? YES NO I DON'T KNOW

If NO, what is wrong with the conclusion? Incorrect claim

c)

Variables	Trial A	Trial B	Trial C	Trial D
Power Plant Type:	Coal			
<u>Substance Amount:</u>	2,700 Mg	3,100 Mg	3,600 Mg	4,200 Mg
Number of Generators:	3			
Water Amount:	4,500 L			
Number of Workers:	10			
Data				
	Trial A	Trial B	Trial C	Trial D
Power:	131 MW	140 MW	147 MW	155 MW
Other:	Air around plant is light brown	Air around plant is brown	Air around plant is brown	Air around plant is dark brown

Possible Conclusion: The greater the amount of coal burned in the power plant, the more polluted the air, because we observed when 2,700 Mg of coal were burned, the air was light brown and when 4,200 Mg of coal were burned, the air was dark brown.

Is this a correct conclusion? YES YES NO I DON'T KNOW

If NO, what is wrong with the conclusion? _____

10

SCIENTIFIC PRACTICES
Analyzing & Interpreting Data

d)

Variables	Trial A	Trial B	Trial C	Trial D
Power Plant Type:	Natural Gas			
Substance Amount:	3,100 Mg			
Number of Generators:	3			
Water Amount:	4,200 L	4,400 L	4,600 L	4,800 L
Number of Workers:	10			
Data	Trial A	Trial B	Trial C	Trial D
Power:	155 MW	147 MW	140 MW	128 MW
Other:	Air around plant is clear	Air around plant is clear	Air around plant is clear	Air around plant is clear

Possible Conclusion: When 4,200 L of water were used, 155 MW of power were produced, and when 4,800 L of water were used, 128 MW of power were produced, because the greater the water amount the smaller the amount of power produced.

Is this a correct conclusion? YES **NO** I DON'T KNOW

If NO, what is wrong with the conclusion? Claim and data switched

e)

Variables	Trial A	Trial B	Trial C	Trial D
Power Plant Type:	Coal			
Substance Amount:	2,800 Mg	3,200 Mg	3,600 Mg	4,000 Mg
Number of Generators:	3			
Water Amount:	4,000 L	4,200 L	4,500 L	4,700 L
Number of Workers:	8			
Data	Trial A	Trial B	Trial C	Trial D
Power:	130 MW	139 MW	145 MW	155 MW
Other:	Air around plant is brown	Air around plant is brown	Air around plant is brown	Air around plant is brown

Possible Conclusion: The greater the water amount used in the power plant, the more power produced, because when 4,000 L of water were used 130 MW of power were produced, and when 4,700 L of water were used, 155 MW of power were produced.

Is this a correct conclusion? YES **NO** I DON'T KNOW

If NO, what is wrong with the conclusion? More than 1 changing variable

3. How many changing variables can you have in order to make a conclusion? 1

11

Below are the explanations and answers to part 2, letters a-e, on pages 9, 10, and 11.

As a class, annotate results table a by identifying and underlining the controls (*Power Plant Type, Substance Amount, Water Amount, and Number of Workers*), circling the changing variable (*Number of Generators*), and boxing the information about the data collected (*Power and Other*). Then, annotate the possible conclusion as a class.

- a. The higher the number of generators the greater the power, because when 2 generators were used, 103 MW of power were produced, and when 5 generators were used, 150 MW of power were produced.

What type of statement is before the 'because,' and how do you know?

Claim, because it can be tested

What is the changing variable in this claim?

Number of generators

Is this a changing variable in this experiment?

Yes

Is the claim consistent with the results table? (check table with students)

Yes

What type of statement is after the 'because,' and how do you know?

Data, because it contains measurements.

Is the data consistent with the results table? (check table with students)

Yes

Is this a correct conclusion?

Yes

As a class, annotate results table b by identifying and underlining the controls (*Power Plant Type, Substance Amount, Number of Generators, and Water Amount*), circling the changing variable (*Number of*

Workers), and boxing the information about the data collected (*Power* and *Other*). Then, annotate the possible conclusion as a class.

- b. The more people working at the power plant, the more power produced, because when 8 people were working, 140 MW of power were produced, and when 14 people were working, 141 MW of power were produced.

***Note:** Circle *people working* and write “# of workers” above to make the changing variable clearer.

What type of statement is before the ‘because,’ and how do you know?

Claim, because it can be tested

What is the changing variable in this claim?

Number of workers

Is this a changing variable in this experiment?

Yes

Is the claim consistent with the results table? (check table with students)

No. You might need to point out that although 14 workers produced the most power, it is only up by 1 MW, and 8 workers produce more power than 10 workers. Therefore, the number of workers does not affect the power output.

Can this be a correct conclusion?

No

What is wrong with the conclusion?

Incorrect claim

Have students individually annotate results table *c* by identifying and underlining the controls (*Power Plant Type*, *Number of Generators*, *Water Amount*, and *Number of Workers*), circling the changing variable (*Substance Amount*), and boxing the information about the data collected (*Power* and *Other*). Then, annotate the possible conclusion as a class.

- c. The greater the amount of coal that is burned in the power plant, the more polluted the air, because we observed when 2,700 Mg of coal were burned, the air was light brown, and when 4,299 Mg of coal were burned, the air was dark brown.

***Note:** Circle *more coal* and write “substance amount” above, because “more coal” really refers to the amount of coal, which in this case is referred to as substance amount in the results table.

What type of statement is before the ‘because,’ and how do you know?

Claim, because it can be tested

What is the changing variable in this claim?

Substance amount

Is this a changing variable in this experiment?

Yes

Is the claim consistent with the results table? (check table with students)

Yes

What type of statement is after the ‘because,’ and how do you know?

Data, because it contains observations

Is the data consistent with the results table? (check table with students)

Yes

Is this a correct conclusion?

Yes

Have students individually annotate results table *d* by identifying and underlining the controls (*Power Plant Type*, *Substance Amount*, *Number of Generators*, and *Number of Workers*), circling the changing

variable (*Water Amount*), and boxing the information about the data collected (*Power* and *Other*). Then, annotate the possible conclusion as a class.

- d. When 4,200 L of water were used, 155 MW of power were produced, and when 4,800 L of water were used, 128 MW of power were produced, because the greater the amount of water the smaller the amount of power produced.

What type of statement is before the 'because,' and how do you know?

Data, because it contains measurements

Is this a correct conclusion?

No

What is wrong with the conclusion?

Claim and data are switched

Have students individually annotate results table e by identifying and underlining the controls (*Power Plant Type*, *Number of Generators*, and *Number of Workers*), circling the changing variables (*Substance Amount* and *Water Amount*), and boxing the information about the data collected (*Power*, and *Other*). Then, annotate the possible conclusion as a class.

- e. The greater the amount of water used in the power plant, the more power produced, because when 4,000 L of water were used, 130 MW of power were produced, and when 4,700 L of water were used, 155 MW of power were produced.

What type of statement is before the 'because,' and how do you know?

Claim, because it can be tested

What is the changing variable in this claim?

Water amount

Is this a changing variable in this experiment?

Yes

Is the claim consistent with the results table? (check table with students)

Yes

What type of statement is after the 'because,' and how do you know?

Data, because it contains measurements

Is the data consistent with the results table? (check table with students)

Yes

Is this a fair conclusion?

No, there are multiple changing variables, therefore, it could be the substance amount which is changing the amount of power produced, and not the water amount.

Is this a correct conclusion?

No

What is wrong with the conclusion?

More than one changing variable

Ask students, "When designing an experiment, how many changing variables can you have in order to make a conclusion from your data?" Students should reply, "Only one." Record this in the class notebook for number 3 on the bottom of page 11 while students do the same in their notebooks.

Tell students, "You are now going to analyze your own data to see whether or not you can make a conclusion. It is okay if you cannot draw a conclusion from your first experiment, because you will have the opportunity to run another experiment. When you run your second experiment, you should only change variable, allowing you to be able to draw a conclusion. Once you have decided whether you can or cannot make a conclusion, you will either use your results to make a conclusion, or state why you cannot make a conclusion from your data."

Tell students, “You will start working with your subgroup to analyze your experiment.”

Conclusion:

(6 minutes – Subgroups – SciTrek Mentors)

Help subgroups fill out page 12 of their notebooks. If the subgroup has more than one changing variable, they will not be able to draw a conclusion. An example of a scenario in which a subgroup cannot make a conclusion is shown below (left).

If the subgroup has only one changing variable, they will be able to make a conclusion. Make sure subgroups’ conclusions have both a claim (statement that can be tested) and supporting data (measurements, observations, and/or calculations), and these statements are in the appropriately labeled sections. If the values of their changing variable have an order (Ex: $80^\circ \rightarrow 65^\circ \rightarrow 45^\circ \rightarrow 30^\circ$), then that variable does have an effect on the power produced by the solar panel. If, on the other hand, there was no order for their changing variable values (Ex: $30^\circ\text{C} \rightarrow 26^\circ\text{C} \rightarrow 44^\circ\text{C} \rightarrow 35^\circ\text{C}$) and/or the difference between the powers for each trial is small, then that variable does not have an effect on the power produced by the solar panel. Since this is an engineering activity, students’ claims should be focused on the value (or pattern of values) of their changing variable that produced the most power, and allows them to make a prediction. An example of an appropriate claim could be: the less shading on the solar panel, the more power is produced. This is an appropriate claim, because it allows students to make a prediction about what would happen if new values of their changing variable were introduced, and identifies which value would produce the most power.

After generating a claim about their experiment, subgroups will put their supporting data after the *because* in their conclusion sentence. Their supporting data should include at least two pieces of data, typically the minimum and maximum power values. Make sure subgroups are using their changing variable values (not trial letters), and specific calculations to support their claims. The supporting data for the previously mentioned claim would be: when the panel was $\frac{8}{8}$ shaded, the power produced was 0 mW, and when the panel was $\frac{0}{8}$ shaded, the power produced was 4.8 mW.

Conclusions are still valid, and important, if they show the changing variable tested does not have an effect on the power produced. Even if their conclusion is contrary to what you think, have subgroups make a claim based solely on their data. An example of a scenario in which a subgroup can make a conclusion, is shown below (right).

CONCLUSION

Making a Conclusion from Your Data

How many changing variables did you have in your experiment? 2

Can you make a conclusion from your data? YES NO

IF NO

Why? We had more than 1 changing variable in our experiment.

IF YES

We can conclude _____ claim

because _____ data (measurement/observation)

SciTrek Member Approval: SL

12

CONCLUSION

Making a Conclusion from Your Data

How many changing variables did you have in your experiment? 1

Can you make a conclusion from your data? YES NO

IF NO

Why? _____

IF YES

We can conclude as the panel angle gets smaller claim
(closer to 30°), more power is produced by
the solar panel,

because when the panel angle was 40°, data (measurements/observations/calculations)
11.6 mW of power were produced and
when the panel angle was 75°,
3.2 mW of power were produced.

SciTrek Member Approval: SL

12

Wrap-Up:
 (1 minute – Full Class – SciTrek Lead)

Tell students, “Next session, you will discuss your findings as a class. After, you will work on developing techniques to help you analyze your data.”

Clean-Up:

1. Collect notebooks with attached nametags.
2. Make sure all calculators have their cover on and are placed back into the calculator box.
3. Place lamps, extension cords, and hair dryers, back into their boxes.
4. Place all other materials into your group box and bring them back to UCSB.

Day 4: Technique/Analysis Activity

Schedule:

- Introduction (SciTrek Lead) – 3 minutes
- Findings Discussion (SciTrek Lead) – 10 minutes
- Technique (SciTrek Lead) – 15 minutes
- Analysis Activity (SciTrek Lead) – 30 minutes
- Wrap-Up (SciTrek Lead) – 2 minutes

Materials:

(3) Mentor Boxes:

- Nametags
- Notebooks
- Mentor instructions

- Mentor lab coat
- (2) Pencils
- (12) Clear rulers

- (NV) Copies of notebook pages 13-18

Lead Box:

- (3) Extra notebooks
- Lead instructions
- Solar Power picture packet
- Lead lab coat

- Time card
- (2) Pencils
- (2) Red pens

- (2) Wet erase markers
- (2) Black pens
- (5) Clear rulers

Notebook Pages and Picture Packet Page:

TECHNIQUE
Trend Lines

Trend lines are used to find trends in data on graphs.

How to draw a trend line:

- Position your ruler on the graph so it goes along with the direction of the points, and places half the points above the ruler and half the points below the ruler. When positioned correctly, all points should be as close as possible to the ruler.
- Trace along the ruler with your pencil. Always extend trend lines to both edges of the graph.

Graph 1
Effects of Natural Gas Amount on Power

Graph 2
Effects of Number of Workers on Power

How to interpret trend lines:

- If the line is increasing (/), or decreasing (\), there is a trend.
- If the line is flat (—), there is no trend.

1. Directions: Answer the questions using Graphs 1 and 2.

a) Which graph(s) represent a changing variable that affects the data? 1 2

b) Which changing variable affects the data?

- Describe the trend by filling in the following sentence frame:
As the percentage of natural gas increases, the power increases.

2. Directions: Answer the question using Graph 3.

What is the challenge in drawing a trend line on this graph?

The points are too close together.

Graph 3
Effects of Number of Workers on Power

13

TECHNIQUE
Designing Experiments

Four UCSB engineers were studying the amount of power being produced by natural gas power plants by examining natural gas amount, water amount, number of workers, and number of generators. They all picked water amount as their changing variable. Two engineers worked independently, and they used different control values for the natural gas amount, number of workers, and number of generators (Graph 1). The other two engineers collaborated, and they picked the same control values for the natural gas amount, number of workers, and number of generators (Graph 2).

4. Directions: Annotate the graphs and draw trend lines for each experiment.

Graph 1
Effects of Water Amount on Power

Graph 2
Effects of Water Amount and Number of Generators on the Power

Controls				Controls			
Engineer Symbol	Natural Gas Amount	Number of Workers	Number of Generators	Engineer Symbol	Natural Gas Amount	Number of Workers	Number of Generators
●	3,200 Mg	8	2	▲	3,200 Mg	10	2
○	2,800 Mg	10	3	△	3,200 Mg	10	4

a) Does percentage of water affect the power of the power plant? YES NO subgroup control

If YES, describe the trend by filling in the following sentence frame:

- As percentage of water increases, the power decreases.

b) What is the power for a power plant that uses 70% of the water, burns 3,200 Mg of natural gas, has 8 workers, and 2 generators? Expected Power: 51 MW

- Why are trend lines important? They allow us to make predictions.

c) Can you predict what the power would be if the engineers studied a power plant that used 60% of the water, burned 3,200 Mg of natural gas, had 10 workers, and 3 generators in the power plant?

- If YES, which graph is more useful to make your prediction? YES NO
- Expected Power: 73 MW

d) What does this mean for your experimental design? We need to collaborate with other groups.

14

SCIENTIFIC PRACTICES
Analyzing & Interpreting Data

A large group of engineers collaborated by dividing into three teams to study the effects of water amount, natural gas amount, number of workers, and number of generators on the power of natural gas power plants. The three teams agreed to keep the number of generators running in the plants constant at 3 for ALL experiments/trials. Now, they need your help to analyze the data.

1. **Directions:** Annotate the graph, draw trend lines for each experiment, and label trend lines with subgroup control values.

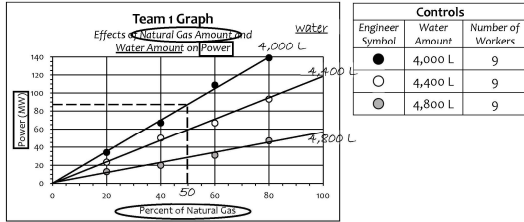

a) Does percentage of natural gas affect the power of the plant? **YES** NO

If YES, describe the trend by filling in the following sentence frame:

• As the percentage of natural gas increases, the power increases.

b) What power would you expect to calculate with the following specifications?

% of Natural Gas	50%
Water Amount	4,000 L
Number of Workers	9

What experiment(s) do you need to look at?

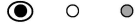

Expected Power:

85 MW

15

SCIENTIFIC PRACTICES
Analyzing & Interpreting Data

2. **Directions:** Annotate the graph, draw trend lines for each experiment, and label trend lines with subgroup control values.

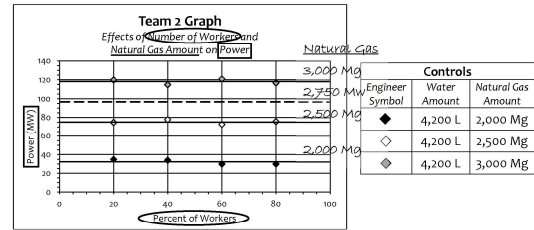

a) Does percentage of workers affect the power of the plant? **YES** **NO**

If YES, describe the trend by filling in the following sentence frame:

• As the percentage of natural gas increases, the power _____.

b) What power would you expect to calculate with the following specifications?

Natural Gas Amount	2,750 Mg
Water Amount	4,200 L
% of Workers	30%

What experiment(s) do you need to look at?



Expected Power:

97 MW

16

SCIENTIFIC PRACTICES
Analyzing & Interpreting Data

3. **Directions:** Annotate the graph, draw trend lines for each experiment, and label trend lines with subgroup control values.

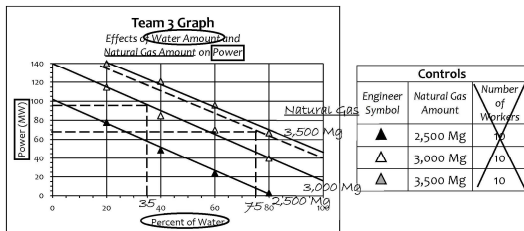

a) Does percentage of water affect the power of the plant? **YES** NO

If YES, describe the trend by filling in the following sentence frame:

• As the percentage of water increases, the power decreases.

b) What power would you expect to calculate with the following specifications?

Natural Gas Amount	3,000 Mg
% of Water	35%
Number of Workers	8

What experiment(s) do you need to look at?



c) What power would you expect to calculate with the following specifications?

Natural Gas Amount	3,400 Mg
% of Water	75%
Number of Workers	10

What experiment(s) do you need to look at?



Expected Power:

95 MW

Expected Power:

67 MW

17

SCIENTIFIC PRACTICES
Analyzing & Interpreting Data

A natural gas power plant wants to know if the trends in their data can be used to predict the power for different combinations of natural gas amount, and water amount, which have not been tested yet. Use teams' 1 and 3 graphs to help the power plant interpret the data.

4. **Directions:** Annotate the graph, draw trend lines for each experiment, and label trend lines with subgroup control values.

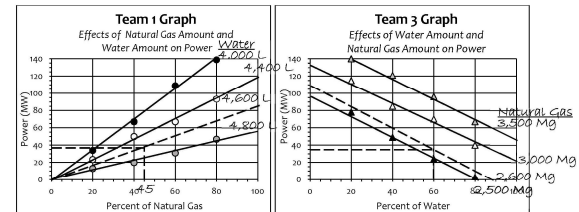

Controls		
Engineer Symbol	Water Amount	Number of Workers
●	4,000 L	9
○	4,400 L	9
□	4,800 L	9

Controls		
Engineer Symbol	Natural Gas Amount	Number of Workers
▲	2,500 Mg	10
△	3,000 Mg	10
▴	3,500 Mg	10

a) Using both of the graphs above, what power would you expect to calculate with the following specifications?

Natural Gas Amount	2,600 Mg	~45%
Water Amount	4,600 L	~60%
Number of Workers	8	~43%

Team 1 Prediction: 36 MW

Team 3 Prediction: 35 MW

What experiment(s) do you need to look at?



Expected Power:

35.5 MW

18

FINDINGS Experiment 1	
Conclusion Summaries:	
Panel Angle:	pane angle ↓ (Closer to 30°), power output ↑
Temperature:	Changing temperature does not affect power output
Shading Amount:	shading angle ↓, power output ↑
Experimental Design:	
• You can only have 1 changing variable	
• Spread out changing variable values	
• Choose common control value with in teams known as team controls	
<div style="border: 1px solid black; display: inline-block; padding: 5px 20px; margin: 0 auto;">Picture Packet, Page 3</div> 3	

Preparation:

SciTrek Lead:

1. Make sure mentors are passing out notebooks.
2. Set up the document camera for the findings discussion (picture packet, page 3), technique activities (notebook, pages 13-14), and analysis activity (notebook, pages 15-18).
3. Make sure that mentors know that they have extra copies of the notebook pages for the technique and analysis activities in their boxes and they know to fill them out with the class. Mentors should sit next to students that might need extra help.

SciTrek Mentors:

1. Pass out notebooks/nametags.
2. Get the extra copy of notebook pages 13-18 and a pencil from your box. Then sit next to the students in your group that you think will need the most help graphing. As the lead runs the activity for the day fill out the pages with students so that they can look at your copy if they need help.

Note: Set notebooks where students usually sit in the class. They will NOT get into their subgroups today.

Introduction:

(3 minutes – Full Class – SciTrek Lead)

Ask students, “What did you do and learn, during the last session with SciTrek?” Possible student response: we conducted experiments to answer the class question, “What variables affect the power produced by a solar panel?” We then looked at conclusions, in order to determine whether they were appropriate, for a given set of data. We used this to analyze our own data and determine whether we could make a conclusion. If we had only one changing variable, then we made conclusions from our data.

Briefly review what they learned about conclusions last time,

What is a conclusion?

A claim supported by data

What is a claim, and what does it usually include?

A statement that can be verified by testing, which may include the changing variable

What type of information can be used for data?

Measurements or observations

What else do we often see in a data statement?

Values of the changing variable

Can the claim and data statements be in any order for the conclusion?

No, the claim must come first, followed by the data that supports it

How many changing variables can we have, in order to make a conclusion and why?

One, if we test more than one changing variable at the same time, there is no way of telling which variable affected the data

Findings Discussion:

(10 minutes – Full Class – SciTrek Lead)

Tell students, “Last session we worked in our subgroups to write a conclusion, if our data allowed. Today, we will discuss our results as a class.”

Place page 3 of the picture packet under the document camera. First, ask students, “Who could not make a conclusion?” For any subgroups that raise their hands, ask them, “Why couldn’t you make a conclusion?” They should reply, “We had more than one changing variable.” Ask those subgroups, “What should you do differently, in order to be able to make a conclusion next time?” They should reply, “We will only choose one changing variable in our next experiment.” Record this on the class findings page, under *Experimental Design* (picture packet, page 3).

Next, go through each variable (panel angle, shading amount, temperature, other [Ex: light height]), and ask students who were able to make a conclusion to raise their hands if this was their changing variable. Have those subgroups read their conclusions. If multiple subgroups had the same changing variable, ask them whether their results agree. Record brief summaries for each variable that was tested on the class findings page under *Conclusion Summaries*. Record all findings about one changing variable before moving onto findings about other changing variables. If subgroups have conflicting conclusions about the same changing variable, record both, and remind the students that we will be conducting more experiments in order to find out how the changing variable affects the power. An example filled out class findings page is shown below. **Note:** there may be only a few, or even zero, subgroups who are able to make conclusions at this point, so you may not be able to record many findings; however, the example below shows possible conclusion summaries for the most commonly chosen changing variables.

FINDINGS Experiment 1	
Conclusion Summaries:	
Panel Angle:	_____
_____	pane angle ↓ (Closer to 30°), power output ↑
_____	_____
Temperature:	_____
_____	Changing temperature does not affect power
_____	output
_____	_____
Shading Amount:	_____
_____	shading angle ↓, power output ↑
_____	_____
Experimental Design:	
_____	• You can only have 1 changing variable
_____	_____
_____	_____
_____	_____
<div style="border: 1px solid black; display: inline-block; padding: 5px 15px; margin: 0 auto;">Picture Packet, Page 3</div>	

3

Technique:

(15 minutes – Full Class – SciTrek Lead)

It is helpful to have mentors sit between students and fill out the technique activity and then scientific practice activity along with students. This allows students to check their work easily. Mentors should have extra copies of these notebook pages in their boxes.

Tell the class, “You are now going to work on techniques to help you analyze your data, this will allow you to design a new, ‘better’ experiments during the next session.” Have mentors pass out a clear ruler, to each student. Keep the picture packet close by, as you will need to record two more class findings during this technique activity.

Tell students, “We are going to learn about trends. Trends are when data changes in one general direction, either going up or going down. If the data points all lie in a flat line, then there is no trend in the data. We are going to use trend lines to help us recognize patterns in data.” Open the class notebook to page 13, under the document camera, and have the students turn to page 13 of their notebooks.

Read the directions for how to draw a trend line (1. Position your ruler on the graph so it goes along with the direction of the points, and places half the points above the ruler and half the points below the ruler. When positioned correctly, all points should be as close as possible to the ruler. 2. Trace along the ruler with your pencil. Always extend trend lines to both edges of the graph.). Then use a clear ruler to show students how to draw a trend line on Graph 1 and have them draw a trend line on Graph 1 in their notebooks. Repeat the process for Graph 2.

Read the directions on how to interpret trend lines to students (If the line is increasing (/), or decreasing (\), there is a trend. If the line is flat (—), there is no trend.). Have students draw in the appropriate lines. **Note:** Use the word ‘flat’ rather than ‘straight’ when describing trend lines showing no trend, because all

lines are straight. Explain to students, “When a graph shows a trend, the changing variable affects the data. When a graph does not show a trend, the changing variable does not affect the data.”

Go over question 1 as a class. Ask students, “Which graph represents a changing variable that affects the data?” Students should reply, “Graph 1.” Circle 1 for question 1a while students do the same in their notebooks. Tell students, “This means that Graph 1 has a trend which we are going to describe.” Ask students, “Which changing variable affect the power produced by a power plant?” Students should reply, Percentage of natural gas.” Circle % of Natural Gas for question 1b while students do the same in their notebooks. Then, ask students, “What happens to the power when the percentage of natural gas increases?” Possible student response: as the percentage of natural gas increases, the power increases. Fill these in for the sentence frame in question 1b while students do the same in their notebooks.

Then, tell students, “I will now draw a trend line onto the data in Graph 3.” Put the ruler on the paper, in the three ways shown in the pictures below. Ask students, “Which placement is correct?” Lead students to understand that it is impossible to tell which way is correct, because the data points are too close together. Finally, ask students, “What does this mean for your experiment?” Possible student response: we need to pick values for our changing variable that are spread out/not close. Add this point to the Findings under *Experimental Design* (picture packet, page 1) and fill in question 2. An example filled out page 13 is shown below.

TECHNIQUE

Trend Lines

Trend lines are used to find trends in data on graphs.

How to draw a trend line:

- Position your ruler on the graph so it goes along with the direction of the points, and places half the points above the ruler and half the points below the ruler. When positioned correctly, all points should be as close as possible to the ruler.
- Trace along the ruler with your pencil. Always extend trend lines to both edges of the graph.

Graph 1
Effects of Natural Gas Amount on Power

Graph 2
Effects of Number of Workers on Power

How to interpret trend lines:

- If the line is increasing (/), or decreasing (\), there is a trend.
- If the line is flat (—), there is no trend.

1. Directions: Answer the questions using Graphs 1 and 2.

a) Which graph(s) represent a changing variable that affects the data? 1 2

b) Which changing variable affects the data?

- Describe the trend by filling in the following sentence frame:

As the percentage of natural gas increases, the power increases.

2. Directions: Answer the question using Graph 3.

What is the challenge in drawing a trend line on this graph?

The points are too close together.

Graph 3
Effects of Number of Workers on Power

13

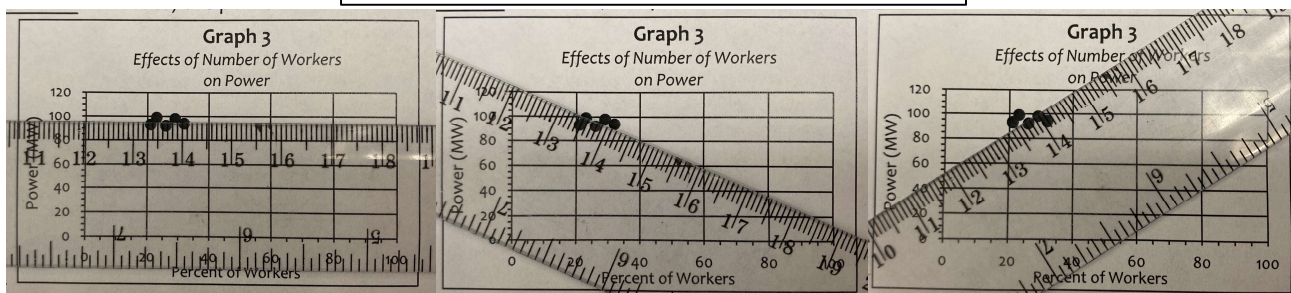

Turn to page 14 in the class notebook, and have students do the same in their notebooks. Tell students, “We will now work on developing techniques, in order to help design experiments as a class. To do this, we are going to examine the results of four engineers who are studying the power of different natural gas power plants. To help analyze the graph, we will annotate it by underlining controls, circling changing variables, and boxing information about data collection. The changing variable is always found on the x-axis (horizontal.)” Ask students, “What is the changing variable in Graph 1 and what are the units?” They should reply, “Percent of water in percentage.” Circle the x-axis title, percent of water and have students do the same. Tell students, “The data collected is found on the y-axis (vertical).” Ask students, “What data was collected and what are the units?” They should reply, “Power in megawatts.” Box the y-axis title, power (MW). Ask students, “Do you see the changing variable or the data anywhere else on the graph?” They should reply, “The title.” Ask students, “What should we do to the title?” They should reply, “Circle water amount and box power.” Tell students, “I also see natural gas amount, number of workers and number of generators, in the title.” Ask them, “What do you think that we should do with these?” If they do not know what to do, show them the table under graph 1, which shows all of these as controls, then underline them.

Tell students, “We are now going to draw on the trend lines for graph 1.” Do this as a class. Once complete, repeat the process for graph 2, making sure students underline number of generators in the graph title.

Ask students, “Why do you think graph 1 has all the controls in the title, but graph 2 only has one control?” Make sure, by the end of the conversation, students understand for graph 1, all the controls had different values; therefore, they all needed to be in the title. However, for graph 2, the engineers had two common control values (number of workers and natural gas amount), so they did not need to put these in the title. Tell students, “When a team of engineers choose control values all together, they are called ‘team controls,’ and when subgroups within a team choose control values that differ from each other, they are called ‘subgroup controls.’” Underneath the graph 2 controls table, have students tell you whether each of the controls is a team control or a subgroup control, then label them. Tell students, “When a team of engineers has only one subgroup control, they can label the trend lines with the different subgroup control values to distinguish them.” In the right margin of graph 2, write # generators and label the two lines with the corresponding subgroup control values.

Ask students, “Does the percent water amount affect the power of the power plant and how do you know?” Possible student response: yes, because all four trend lines show a downward trend. Students should fill out the sentence frame for 3a: *As percentage of water increases, the power decreases.* Make sure students understand both graphs are valid, in order to show percent of water has an effect on the power.

Tell students, “Let’s see if we can predict the power for a power plant that uses 70% of the water, burns 3,200 Mg of natural gas, has 8 workers, and 2 generators. We do not have to be worried about the changing variable value, since the scale ranges from 0-100%.” Walk students through each of the control values in question, and ask them, “Which trend line, on either graph, has the appropriate control values that match these?” Possible student response: the black circle and both of the triangle trend lines correspond to 3,200 Mg of natural gas, but only the black circle trend line also has the 8 workers and 2 generators as controls. Tell students, “We will use this trend line to estimate the power.” Ask students, “Where does 70% of water appear on the x-axis?” They should reply, “Halfway between 60% and 80%.” Put a small hash mark at 70% and label it. Place your ruler vertically on the graph going from 70% of water up to the black circle trend line and draw a dashed line. Have students do the same. Next, lay your ruler horizontally starting at the intersection point of your dashed line and the black circle trend line. Draw another dashed line tracing back to the y-axis. Tell students, “The point where your dashed line touches on the y-axis is your expected power.” Ask students, “What is the expected power produced by this plant?” Possible student response: 51 MW. Write the value down for question 3b. Tell students, “Because

these are predictions, they are approximate numbers. As long as you are within 2 MW of my estimated power, you have drawn an acceptable trend line, and can consider your power correct.” If any students do not get within 2 MW of your estimated power, have a mentor go and check their graph/trend line. Ask students, “Why are trend lines important?” Possible student response: we can use trend lines to make predictions from our graphs. Record this answer for question 3b.

Read question 3c to students (*Can you predict what the power would be if the engineers studied a power plant that used 60% of the water, burned 3,200 Mg of natural gas, had 10 workers, and had 3 generators in the power plant?*). Walk students through each of the control values in the questions and ask them, “Which trend line, on either graph, has the appropriate control values that match these?” Students should notice that neither graph has the exact control values. Ask students, “Since neither graph has exactly what we want, are any of the lines close to the values we want?” Students should notice that the black triangles (2 generators) and the white triangles (4 generator) gave the correct natural gas amount (3,200 Mg) and the correct number of workers 10. Tell students, “Since the lines do not cross and 3 generators is between 2 and 4 generators, we should be able to draw in an estimated trend line for 3 generators and then predict the power.” Have students circle Yes and 2 for question 3c.

Tell students, “I will now show you how to draw on the estimated trend line in graph 2.” Ask students, “Where does 3 generators fall with relation to 2 and 4 generators?” Possible student response: it is directly between 2 and 4. Put dots on both vertical axes of graph 2, in the approximate location of the 3 generators trend line, then use a ruler to draw a dashed line between the two dots creating the estimated 3 generator trend line. Then label the line in the graph margins as 3 and have students do the same in their notebooks. Tell students, “Now, we have a line with all of the values of the controls in the question, therefore, we can estimate the power produced.” Show students how to draw a vertical dashed line, up from 60% on the x-axis, to the new trend line. Then, show them how to draw a flat, horizontal dashed line, over to the y-axis, to find the estimated power (73 MW). Remind students, “These are approximate numbers, so if you are within 2 MW of my estimated power, you should consider your power correct.” Have students fill out question 3c with their predicted power. Ask students, “What did the scientists do that made graph 2 more useful, and what does this mean for your experimental design?” Make sure, by the end of the conversation, students understand they need to collaborate with subgroups with the same changing variable, when they select their control values. Add this point to the class findings list under *Experimental Design* (picture packet, page 3). An example filled out page 14 (left), and complete findings list (right), are shown below.

TECHNIQUE
Designing Experiments

Four UCSB engineers were studying the amount of power being produced by natural gas power plants by examining natural gas amount, water amount, number of workers, and number of generators. They all picked water amount as their changing variable. Two engineers worked independently, and they used different control values for the natural gas amount, number of workers, and number of generators (Graph 1). The other two engineers collaborated, and they picked the same control values for the natural gas amount, number of workers, and number of generators (Graph 2).

4. **Directions:** Annotate the graphs and draw trend lines for each experiment.

Graph 1
Effects of Water Amount, Natural Gas Amount, Number of Workers, and Number of Generators on the Power

Graph 2
Effects of Water Amount and Number of Generators on the Power

Controls			
Engineer Symbol	Natural Gas Amount	Number of Workers	Number of Generators
●	3,200 Mg	8	2
○	2,800 Mg	10	3

Controls			
Engineer Symbol	Natural Gas Amount	Number of Workers	Number of Generators
▲	3,200 Mg	10	2
△	3,200 Mg	10	4

a) Does percentage of water affect the power of the power plant? **YES** YES NO
 If YES, describe the trend by filling in the following sentence frame:
 • As percentage of water increases, the power decreases.

b) What is the power for a power plant that uses 70% of the water, burns 3,200 Mg of natural gas, has 8 workers, and 2 generators? **Expected Power: 51 MW**
 • Why are trend lines important? They allow us to make predictions.

c) Can you predict what the power would be if the engineers studied a power plant that used 60% of the water, burned 3,200 Mg of natural gas, had 10 workers, and 3 generators in the power plant? **YES** YES NO
 • If YES, which graph is more useful to make your prediction? **1** 1 2
Expected Power: 73 MW

d) What does this mean for your experimental design? We need to collaborate with other groups.

14

FINDINGS
Experiment 1

Conclusion Summaries:

Panel Angle:
pane angle ↓ (Closer to 30°), power output ↑

Temperature:
Changing temperature does not affect power output

Shading Amount:
shading amount ↓, power output ↑

Experimental Design:

- You can only have 1 changing variable
- Spread out changing variable values
- Choose common control value within teams known as team controls

Picture Packet, Page 3

3

Analysis Activity:

(30 minutes – Full Class – SciTrek Lead)

Turn to page 15 in the class notebook under the document camera, and have students turn to page 15 in their notebooks. Tell students, “We will continue discussing the engineers who studied the effects of water amount, natural gas amount, number of workers, and number of generators on the amount of power that natural gas power plants produce. They collected data by dividing into three teams, each choosing one of the variables as their changing variable. In addition, they all chose to keep the number of generators constant at 3. We will start analyzing their data by annotating and labeling the graph.” As a class annotate the graph, draw on trend lines, and label the trend line with the subgroup control values.

Ask students, “What is the changing variable Team 1 tested?” They should reply, “Percent of natural gas.” Point out that number of workers was a team control and water amount was a subgroup control. Ask students, “Do you see a trend, and, if so, what does this mean?” Possible student response: there is a trend, and it means that natural gas amount affects the power. Then, ask students, “What happens to the power when the percentage of natural gas increases?” They should reply, “Power increases.” Fill in question 1a, and have students do the same in their notebooks.

Tell students, “We are going to use Team 1’s data to predict the power if there was a plant that used 50% natural gas, 4,000 L of water, and 9 workers.” Ask students, “Do we need to consider the percentage of natural gas?” Possible student response: no, because it is the changing variable and we can select the value we want. Ask students, “Do we need to consider number of workers and why?” Possible student response: no, because the number of workers is 9, which is a team control value. Ask students, “Do we need to consider water amount and why?” Possible student response: yes, because we need 4,000 L and all lines have different values. Have students look at the water amounts that team 1 tested (4,000 L, 4,400 L, and 4,800 L), and compare them with the water amount in this question (4,000 L). Ask students, “Which experiment, or experiments, will we need to look at and why?” Possible student response: we should look at the black circles, because 4,000 L of water were used in that experiment. Circle the black circle for question 1b. Have students look at the trend line for the black circles. Ask students, “What percentage of

natural gas are we interested in?" Students should reply, "50%." Find 50% on the x-axis and write it in. Use the ruler to draw a dashed line, straight up to the trend line for the black circles. Then, find the predicted power by using the ruler to draw a second, horizontal dashed line straight across to the y-axis, which is roughly 85 MW. Remind students, "Your predicted value can be off by up to 2 MW, because these are estimates." Write "85 MW" into the class notebook and have students write their estimated power values into their notebooks. An example filled out page 15 is shown below (left).

SCIENTIFIC PRACTICES
Analyzing & Interpreting Data

A large group of engineers collaborated by dividing into three teams to study the effects of water amount, natural gas amount, number of workers, and number of generators on the power of natural gas power plants. The three teams agreed to keep the number of generators running in the plants constant at 3 for ALL experiments/trials. Now, they need your help to analyze the data.

1. Directions: Annotate the graph, draw trend lines for each experiment, and label trend lines with subgroup control values.

Team 1 Graph
Effects of Natural Gas Amount and Water Amount on Power

Controls		
Engineer Symbol	Water Amount	Number of Workers
●	4,000 L	9
○	4,400 L	9
●	4,800 L	9

a) Does percentage of natural gas affect the power of the plant? YES NO
If YES, describe the trend by filling in the following sentence frame:

- As the percentage of natural gas increases, the power increases.

b) What power would you expect to calculate with the following specifications?

% of Natural Gas	50%
Water Amount	4,000 L
Number of Workers	9

What experiment(s) do you need to look at?

Expected Power:
85 MW

15

SCIENTIFIC PRACTICES
Analyzing & Interpreting Data

2. Directions: Annotate the graph, draw trend lines for each experiment, and label trend lines with subgroup control values.

Team 2 Graph
Effects of Number of Workers and Natural Gas Amount on Power

Controls		
Engineer Symbol	Water Amount	Natural Gas Amount
●	4,200 L	2,000 Mg
◇	4,200 L	2,500 Mg
◇	4,200 L	3,000 Mg

a) Does percentage of workers affect the power of the plant? YES NO
If YES, describe the trend by filling in the following sentence frame:

- As the percentage of natural gas increases, the power _____.

b) What power would you expect to calculate with the following specifications?

Natural Gas Amount	2,750 Mg
Water Amount	4,200 L
% of Workers	30%

What experiment(s) do you need to look at?

Expected Power:
97 MW

16

Have students turn to page 16 in their notebooks. If you think students are ready, give them time to annotate the graph, draw on trend lines, and label the trend lines with the subgroup control values on their own, otherwise do this as a class. If students are doing the process on their own, do the same in the class notebook off to the side of the document camera. When the majority of students are done, put the class notebook under the document camera for students to check their work.

Ask students, "What was the changing variable that team 2 tested?" They should reply, "Percent of workers." Point out that water amount is a team control and natural gas amount is a subgroup control. Ask students, "Do you see a trend, and what does this mean?" Possible student response: there is not a trend and this means the number of workers does not affect the power produced. Circle NO on question 2a and have students do the same in their notebooks. Since there is no trend, the sentence frame in 2a does not need to be filled in.

Tell students, "We are going to use team's 2 data to predict the power if we were to have a power plant with 2,750 Mg of natural gas, 4,200 L of water, and 30% of workers. Ask students, "Do we need to consider percentage of workers and why?" Possible student response: no, because it is the changing variable and we can select the value we want. Ask students, "Do we need to consider water amount and why?" Possible student response: no, because the value to be used was 4,200 L, which is a team control value. Ask students, "Do we need to consider natural gas amount and why?" Possible student response: yes, because the value to be use is 2,750 Mg and all lines have different values. Have students look at the natural gas amounts that team 2 tested (2,000 Mg, 2,500 Mg, and 3,000 Mg) and compare them with the

natural gas amount in this question (2,750 Mg). Ask students, “Which experiment, or experiments, will we need to look at and why?” Possible student response: we should look at the white and grey diamonds, because 2,750 Mg was used which is between 2,500 Mg and 3,000 Mg. Circle the white and gray diamonds for question 2b. Tell students, “Because the 2,750 Mg trend line is not already on the graph we will need to estimate where it is.” Ask students, “Where does 2,750 MG fall, with relation to 2,500 Mg and 3,000 Mg?” Possible student response: it is directly between 2,500 Mg and 3,000 Mg. Put dots on both vertical axes of team 2 graph in the approximate location of the 2,750 Mg trend line, then use a ruler to draw a dashed line between the dots creating the estimated 2,750 Mg trend line. Then label the line in the graph margins as 2,750 Mg. Tell students, “Because number of workers does not affect the power, we do not need to label to percentage of workers that we are interested in on the x axis because all values will give the same power. We can just look at where our estimated trend line hits the y axis.” Have students find their estimated power, which is roughly 97 MW. Remind students, “Your predicted value can be off by up to 2 MW, because these are estimates.” Write “97 MW” into the class notebook and have students write their estimated power into their notebooks. An example filled out page 16 is shown above (right).

Have students turn to page 17 in their notebooks and give students time to annotate the graph, draw on trend lines, and label the trend lines with the subgroup control values, on their own. Do the same in the class notebook off to the side of the document camera. When the majority of students are done, put the class notebook under the document camera for students to check their work.

Ask students, “What was the changing variable that team 3 tested?” They should reply, “Percent of water.” Point out that number of workers is a team control, and natural gas amount is a subgroup control. Ask students, “Do you see a trend, and, if so, what does this mean?” Possible student response: there is a trend and it means water amount affects the power produced. Then, ask students, “What happens to the power as the percentage of water increases?” They should reply, “The power decreases.” Fill in the sentence frame under question 3a and have students do the same in their notebooks.

Tell students, “We are going to use team 3’s data to predict the power if we were to have a power plant with 3,000 Mg of natural gas, 35 % of water, and 8 workers.” Ask students, “Is there any irrelevant information or information that we do not need to worry about and Why?” If students are struggling, ask them what team 2 discovered. Possible student response: we do not need to worry about the number of workers because it does not affect the power. Tell students, “You should cross off number of workers and its values, on the control charts on this page, to remind us that we do not need to worry about this variable. This is helpful because now we can focus on just one control, natural gas amount.”

As a class go through determining the expected power from a trend line (question 3b) and an estimated trend line (question 3c). An example filled out page 17 is shown below (left).

SCIENTIFIC PRACTICES
Analyzing & Interpreting Data

3. **Directions:** Annotate the graph, draw trend lines for each experiment, and label trend lines with subgroup control values.

Team 3 Graph
Effects of Water Amount and Natural Gas Amount on Power

Controls		
Engineer Symbol	Natural Gas Amount	Number of Workers
▲	2,500 Mg	10
△	3,000 Mg	10
△	3,500 Mg	10

a) Does percentage of water affect the power of the plant? **YES** NO
If YES, describe the trend by filling in the following sentence frame:

- As the percentage of water increases, the power decreases.

b) What power would you expect to calculate with the following specifications?

Natural Gas Amount	3,000 Mg
% of Water	35%
Number of Workers	8

Expected Power:
9.5 MW

What experiment(s) do you need to look at?
 ▲ ○ ▲

c) What power would you expect to calculate with the following specifications?

Natural Gas Amount	3,400 Mg
% of Water	75%
Number of Workers	10

Expected Power:
6.7 MW

What experiment(s) do you need to look at?
 ▲ ○ ▲

17

SCIENTIFIC PRACTICES
Analyzing & Interpreting Data

A natural gas power plant wants to know if the trends in their data can be used to predict the power for different combinations of natural gas amount, and water amount, which have not been tested yet. Use teams' 1 and 3 graphs to help the power plant interpret the data.

4. **Directions:** Annotate the graph, draw trend lines for each experiment, and label trend lines with subgroup control values.

Team 1 Graph
Effects of Natural Gas Amount and Water Amount on Power

Team 3 Graph
Effects of Water Amount and Natural Gas Amount on Power

Controls		
Engineer Symbol	Water Amount	Number of Workers
●	4,000 L	9
○	4,400 L	9
○	4,800 L	9

Controls		
Engineer Symbol	Natural Gas Amount	Number of Workers
▲	2,500 Mg	10
△	3,000 Mg	10
△	3,500 Mg	10

a) Using **both** of the graphs above, what power would you expect to calculate with the following specifications?

Natural Gas Amount	2,600 Mg	~45%
Water Amount	4,600 L	~60%
Number of Workers	8	~43%

Team 1 Prediction: 36 MW

Team 3 Prediction: 35 MW

What experiment(s) do you need to look at?

Team 1: ● ○ ●

Team 3: ▲ ○ ▲

Expected Power:
35.5 MW

18

Turn to page 18 in the class notebook under the document camera, and have students turn to page 18 in their notebooks. Tell students, “The engineers are now interested in looking at all of the teams’ data together, in order to make predictions about the power for different combinations of the variables. I have copied the team 1 and team 3 graphs onto this page, so we can look at the data at the same time.” Do not have students annotate the graphs on page 18 because they have already done this on the previous pages’ graphs. Have students draw and label the trend lines on the graph with the subgroup values.

Ask students, “Why do you think team 2’s graph is not printed here?” Possible student response: Team 2 found out the number of workers did not affect the power, so we do not need to worry about team 2’s graph when predicting power output. Then, ask students, “Is there any irrelevant information, that we could cross out, on this page and why?” Possible student response: we could cross off the number of workers, because this did not affect the power. Cross off number of workers in the class notebook, and have students do the same in their notebooks.

Read the directions for question 4a (*Using both of the graphs above, what power would you expect to calculate with the following specifications?*); then read the specifications of the power plant that will be used from the table. Tell students, “We are going to use team 1’s data to predict the power with the specifications provided. Then, we will use team 3’s data to make a prediction about the same specifications. We will then be able to compare the two predictions, to make a final prediction that takes all of the pertinent data into account.”

Look at the team 1’s graph, and read the specifications of the power plant from the table again. Tell students, “We should focus on water amount first, because it is a subgroup control for this team.” Have students compare the water amount values that team 1 tested (4,000 L, 4,400 L, and 4,800 L), with the amount of water in this question (4,600 L). Ask students, “Which experiment(s)/trend line(s) will we need to look at and why?” Possible student response: the white and gray circles, because 4,600 L is between 4,400 L and 4,800 L. Circle the gray and white circles for team 1 on 4a. Have student determine the estimated power on their own. When the majority of students are finished, put the class notebook under

the document camera and quick draw on the estimated trend line and show them how you got your prediction of 36 mW

Tell students, “We are now going to use team 3’s data to make a prediction about the power using the same specifications.” Repeat the process that was done for team 1’s graph with team 3 graph. Team 3 prediction should be approximately 35 MW.

Ask students, “Which team’s prediction should we use for our final expected power?” Lead students to understand that we want to use a combination of both team’s predictions, to make our final prediction. Since team 1 predicted the power to be 36 MW and team 3 predicted the power to be 35 MW, the predicted power should be between those values at 35.5 MW. Write this number in the class notebook, in the box for expected power, and have the students write the powers they predicted in their notebooks. Remind students, “Your predictions can differ from the one in the class notebook by up to 2 MW.” An example filled out page 18 is shown above (right).

Wrap-Up:

(2 minutes – Full Class – SciTrek Lead)

Tell students, “Next session, you will design new experiments using the techniques you learned today.”

Clean-Up:

1. Collect notebooks with attached nametags.
2. Place all other materials into your group box and bring them back to UCSB.

Day 5: Technique/Question/Experimental Set-Up/Procedure/Results Table**Schedule:**

Introduction (SciTrek Lead) – 2 minutes
Technique (SciTrek Lead) – 8 minutes
Class Plan Discussion (SciTrek Lead) – 15 minutes
Team Plan Discussion (SciTrek Mentor) – 7 minutes
Question (SciTrek Mentors) – 5 minutes
Experimental Set-Up (SciTrek Mentors) – 5 minutes
Procedure (SciTrek Mentors) – 11 minutes
Results Table (SciTrek Mentors) – 5 minutes
Wrap-Up (SciTrek Lead) – 2 minutes

Materials:
(3) Mentor Boxes:

- Nametags
- Notebooks
- Mentor instructions

- Mentor lab coat
- (2) Pencils

- (2) Red pens
- Paper notepad

Other Supplies:

- Calculator box

Lead Box:

- (3) Extra notebooks
- Lead instructions
- Solar Power picture packet
- Lead lab coat

- (2) Sets of team plans
- Time card
- (2) Pencils
- (2) Red pens

- (2) Wet erase markers
- (2) Black pens
- Paper notepad
- Subgroup fair sticks (in Ziploc)

Notebook Pages and Picture Packet Page:

TECHNIQUE
Calculating Percentages

Percentages are used to compare a portion of a system to a whole system. This is done by making the amount of the whole system equal to 100%. The closer the value is to 100%, the larger the portion of the system.

How to calculate a percentage:

Step 1. Define your system:

- Determine the number you want to change into a percent (*value*).
- Determine the smallest number in your system (*min value*).
- Determine the largest number in your system (*max value*).

Step 2. Calculate the **range**:
 $range = max\ value - min\ value$

Step 3. Calculate the **percentage**:
Round the percentage to the nearest whole number. Percentages have units of %.
 $\% \text{ changing variable} = 100 \times \left(\frac{value - min\ value}{range} \right)$

Directions: Find the percent for each of the following values in the table.

1) Panel Angle: 50°	2) Shading Amount: $\frac{6}{8}$
Allowed values for each variable:	
Step 1: Panel Angle: (30° - 75°)	Shading Amount: ($\frac{0}{8}$ - $\frac{8}{8}$)
Step 2: Range = $75 - 30$ = 45	Range = $\frac{8}{8} - \frac{0}{8}$ = 1
Step 3: %Angled = $100 \times \left(\frac{50 - 30}{45} \right)$ = 44%	%Shaded = $100 \times \left(\frac{6/8 - 0/8}{1} \right)$ = 75%

19

CLASS PLAN

Subgroup: The original people you worked with.
Team: Multiple subgroups that are investigating the same changing variable.
Class Control: A control that everyone in the class has the same value for.

- The class picks this value together.

Team Control: A control that everyone in a team has the same value for, but values vary for different teams within a class.

- Teams pick this value together.

Subgroup Control: A control that everyone in a subgroup has the same value for, but values vary for different subgroups within a team.

- Subgroups pick this value on their own, with team input.

Changing Variable: The variable that is purposely changed in an experiment.

- Each subgroup picks multiple values on their own

Class Control
Light Height / 14 cm

Team Panel Angle

Orange 1 Blue 1 Green 1
 Orange 2 Blue 2 Green 2

Team Shading Amount

Orange 1 Blue 1 Green 1
 Orange 2 Blue 2 Green 2

Team Temperature

Orange 1 Blue 1 Green 1
 Orange 2 Blue 2 Green 2

Picture Packet, Page 4

4

Our subgroup is on team: Shading amount

Variables	Min Value	Max Value
Panel Angle:	30°	75°
Shading Amount:	0 8	8 8
Temperature:	19°C	44°C

The range for our changing variable is:

$$\text{range} = \text{max value} - \text{min value}$$

$$8/8 - 0/8 = 8/8 = 1$$

- As a subgroup select and record the values of your changing variable in the table below.

Team Temperature: Choose any whole number temperatures between 25°C and 44°C. You may also choose room temperature (ranges from 19°C - 24°C) as one of your four values. If you select this value, write "RT" on the line; you will record the numerical value of the room temperature and determine the percent temperature on the experiment day.

- Use the following equation to calculate the percent of your change variable values.

$$\% \text{ changing variable} = 100 \times \left(\frac{\text{value} - \text{min value}}{\text{range}} \right)$$

1) Changing Variable Value 1: <u>0/8</u>	2) Changing Variable Value 2: <u>4/8</u>
% Changing Variable = $100 \times \left(\frac{0/8 - 0/8}{1} \right) = 0\%$	% Changing Variable = $100 \times \left(\frac{4/8 - 0/8}{1} \right) = 50\%$
3) Changing Variable Value 3: <u>6/8</u>	4) Changing Variable Value 4: <u>8/8</u>
% Changing Variable = $100 \times \left(\frac{6/8 - 0/8}{1} \right) = 75\%$	% Changing Variable = $100 \times \left(\frac{8/8 - 0/8}{1} \right) = 100\%$

20

QUESTION

Question our subgroup will investigate:

- If we change the shading amount
insert each changing variable (independent variable)
what will happen to the power produced by the solar
insert what you are calculating
panel?

EXPERIMENTAL SET-UP

Write your changing variable(s) (Ex: panel angle) and the values (Ex: 45°) you will use for your trials under each solar panel.

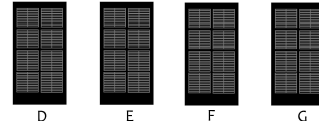

Changing Variable(s):

1) Shading Amount: 0/8 4/8 6/8 8/8

2) _____

Why did your subgroup choose these values of the changing variable? We spread out our changing variable values so our data points will also be spread out.

Controls (variables you will hold constant):

Write your controls and the values you will use in all your trials (control/value, Ex: power source/solar panel).

Class and Team Controls:
(same values between subgroups)

Subgroup Control:
(different values between subgroups)

Power Source / Solar Panel Panel Angle / 30°

Temperature / RT

Light Height / 14 cm

SciTrek Member Approval: SL

21

PROCEDURE

Procedure Note:

Make sure to include all values of your changing variable(s) in the procedure. Ex: For a subgroup that decided to change panel angle one step would be: Place the panel at an angle of D) 30°, E) 45°, F) 60°, and G) 75°.

- Set up lamp using the spacing tool 14 cm above panel.
- Place shading tool on solar panel at D) 0/8, E) 4/8, F) 6/8, and G) 8/8 shaded.
- Place the panel at an 30° angle.
- Position panel directly under lamp, and turn lamp on.
- Do not heat the solar panel, leave at RT.
- Use multimeter to measure the current (mA) and voltage (V).
- Calculate the power by multiplying current and voltage.
- _____

SciTrek Member Approval: SL

22

RESULTS

Table

Check the box of your subgroup control and write your subgroup symbol on the line. Then, fill out the table for each of your trials. For the variables that remain constant, write the value in Trial D. Then, draw an arrow through each box indicating the variable is a control. Remember to record measurements to the nearest tenth (Ex. 4.1 mA), calculate power to the nearest tenth (Ex. 13.2 mW), and percentages to the nearest whole number (Ex. 75%).

Subgroup Control: Panel Angle Shading Amount Temperature Subgroup Symbol: o

Variables	Trial D	Trial E	Trial F	Trial G
Power Source:	<u>Solar panel</u>			
Panel Angle:	<u>30°</u>			
Shading Amount:	<u>0/8</u>	<u>4/8</u>	<u>6/8</u>	<u>8/8</u>
Temperature:				
Room Temp: <u>22°C</u>	<u>RT</u>			
Light Height:	<u>14 cm</u>			
Predictions	Trial D	Trial E	Trial F	Trial G
Put an "S" in the trial that will give the smallest power and an "L" in the trial that will give the largest power.	<u>L</u>			<u>S</u>
Data and Calculations	Trial D	Trial E	Trial F	Trial G
Measurements:				
Current (mA):				
Voltage (V):				
Calculations:				
Percent Changing Variable: (get values from pg. 20)				
Power (mW): $P = I \times V$				

The independent variable is the changing variable and the dependent variables are the current and voltage.

23

Preparation:

SciTrek Lead:

1. Make sure mentors know what team they will work with once students form teams.
2. Make sure mentors are passing out notebooks and rulers.
3. Set up the document camera for the technique activity (notebook, pages 19) and class plan discussion (picture packet, page 4).

SciTrek Mentors:

1. Pass out notebooks/nametags.
2. Have a red pen available to approve students' question, experimental set-up, and procedures (notebook, pages 21-22).

Note: Pass out notebooks to students. If needed, students will move to their subgroups after the technique activity.

Introduction:

(2 minutes – Full Class – SciTrek Lead)

If students are not in their subgroups, tell students, "You will move to your subgroups after the technique activity."

Ask students, "What did you do and learn, during the last session with SciTrek?" Possible student response: last session we learned how to use trend lines to make predictions about the amount of power a power plant could produce. We also learned that when groups collaborate to pick control values additional predictions can be made. Tell students, "Today we will learn a technique that will make it easier for us to compare data between subgroups in our next experiment. Then, we will redesign our next experiment."

Technique:

(8 minutes – Full Class – SciTrek Lead)

Have the mentors pass out a calculator to each student.

Ask the class, "What were the units we used when measuring the panel angle?" They should reply, "Degrees." Repeat the question for shading amount (fraction), and temperature (degrees Celsius). Tell students, "After we carry out our experiments, we will want to graph our results so we can make predictions like we did in the analysis activity. However, in order to graph our results, we must all be using the same scale, that way we can accurately compare how each of the variables affect the power produced by the solar panel. Since each of the variables uses different units, we can solve this problem by graphing in percentages."

Have students turn to page 19 in their notebook while you turn the class notebook to page 19 under the document camera. Read the paragraph at the top of page 19 to students. *Percentages are used to compare a portion of a system to a whole system. This is done by making the amount of the whole system equal to 100%. The closer the value is to 100%, the larger the portion of the system.*

Tell students, "To find the percentage you will use three steps." Direct student attention to Step 1 and read it to them (*Define your system: a. Determine the number you want to changing into a percent (value). b. Determine the smallest number in your system (min value). c. Determine the largest number in your system (max value).*). Have students look at number 1. Tell students, "The system refers to the variable we are working with in the problem." Ask students, "What variable are we working with in

number 1?" Students should reply, "Panel angle." Ask students, "What value do we want to change into a percent?" Student should reply, "50°." Direct students' attention to the *allowed values for each variable* section of the table. Ask students, "What is the minimum value in our system?" Students should reply, "30°." Ask students, "What is the maximum value in our system?" Students should reply, "75°."

Read Step 2 to students (*Calculate the range*). Tell students, "The range equals the difference between the largest and smallest allowed values in your system." Point to the equation on the page. Have students write the max value in the first blank and the min value in the second blank. Ask students, "What is $75^\circ - 30^\circ$ equal to?" Then, write the answer (45°) in the third blank.

Tell students, "Now that we've found our range, we can move on to Step 3." Read Step 3 to students (*Calculate the percentage: Round the percentage to the nearest whole number. Percentages have units of %*). Point to the equation on the page and tell students, "We need to fill in the equation frame in number 1 with our values. Since percentages are unitless, we will not write units on the numbers that we plug into the equation." (**Note:** 6th grade does not cover unit cancellation, so forgoing the units in the percentage equation is a workaround to teaching unit cancellation.) Ask students, "What is our value?" Once students have identified it is 50, write it in the appropriate blank in the equation frame. Ask students, "What is the minimum value?" Once students have identified it is 30, write it in the appropriate blank in the equation frame. Ask students, "What is the range?" Once students have identified that it is 45, write it in the appropriate blank in the equation frame.

Place a calculator under the document camera and turn it on. Show students how to input the equation into the calculator. A picture of the screen is shown below. (**Note:** in order to create the fraction, you must press the " $\frac{n}{d}$ " button on the calculator.)

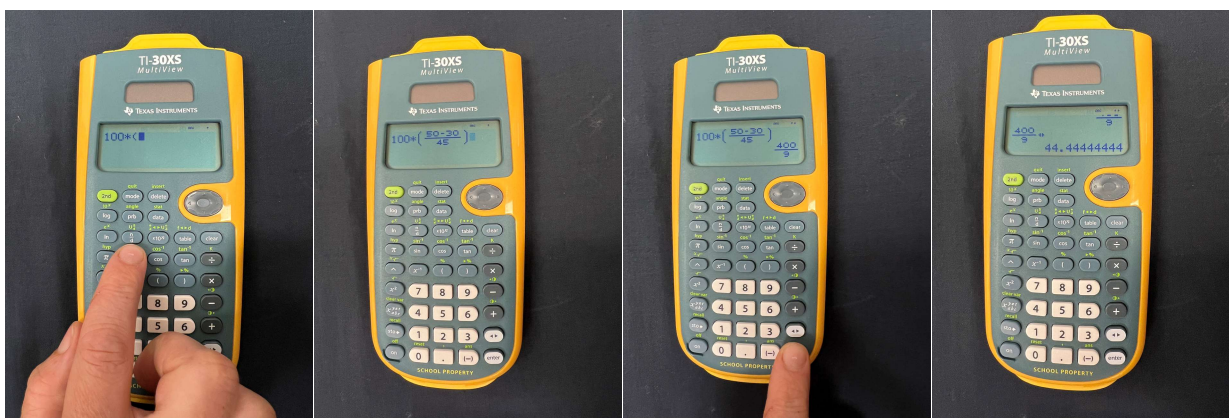

Press the "enter" button on the calculator. The calculator will produce an improper fraction as the answer. Tell students, "To convert this to a decimal, we will press the " $\leftarrow \rightarrow$ " button on the calculator." Your screen will now show a repeating decimal (44.44). Tell students, "We need to round this number to the nearest whole number." They should round to 44%. Record this answer for number 1. Repeat this process for number 2. An example filled out page 19 is shown below.

TECHNIQUE
Calculating Percentages

Percentages are used to compare a portion of a system to a whole system. This is done by making the amount of the whole system equal to 100%. The closer the value is to 100%, the larger the portion of the system.

How to calculate a percentage:

Step 1. Define your system:

- Determine the number you want to change into a percent (*value*).
- Determine the smallest number in your system (*min value*).
- Determine the largest number in your system (*max value*).

Step 2. Calculate the **range**: $range = max\ value - min\ value$

Step 3. Calculate the **percentage**:
Round the percentage to the nearest whole number. Percentages have units of %.

$$\% \text{ changing variable} = 100 \times \left(\frac{value - min\ value}{range} \right)$$

Directions: Find the percent for each of the following values in the table.

1) Panel Angle: 50°	2) Shading Amount: $\frac{6}{8}$
Allowed values for each variable:	
Step 1: Panel Angle: (30° – 75°)	Shading Amount: $\left(\frac{0}{8} - \frac{8}{8}\right)$
Step 2: Range = $\frac{75}{-} - \frac{30}{-}$ = $\frac{45}{-}$	Range = $\frac{8/8}{-} - \frac{0/8}{-}$ = $\frac{1}{-}$
Step 3: %Angled = $100 \times \left(\frac{50 - 30}{45} \right)$ = $\frac{44}{-}\%$	%Shaded = $100 \times \left(\frac{6/8 - 0/8}{1} \right)$ = $\frac{75}{-}\%$

19

Class Plan Discussion:

(15 minutes – Full Class – SciTrek Lead)

If students are not already in their subgroups, have them move to be next to their subgroup members.

Place the *Findings* page (picture packet, page 3) under the document camera. Review with students the *Experimental Design* findings: only have one changing variable, spread out changing variable values, and choose common control values. Ask students, “When we design our next experiment, what do we need to do?” Possible student response: we need to work together as a class and between subgroups to choose common control values.

Tell the class, “You are now going to begin planning your next investigation. You will soon split up into teams to collaborate and work on answering the class question, just like the engineers in the analysis activity. Remember, the groups you worked with on your first experiments were called ‘subgroups.’ Each subgroup will decide which changing variable they want to study in their next experiment. Then, subgroups interested in the same changing variable will join together to form a ‘team.’” Ask students, “Should subgroups on the same team pick their controls independently and why?” Possible student response: no, because subgroups that are investigating the same changing variable need to collaborate, so that we can get more information from the data. If they are struggling with this concept, turn to page 14 of the class notebook and review the graphs before and after the engineers collaborated.

Ask students, “What are the changing variables we are investigating?” They should reply, “Panel angle, shading amount, and temperature.” Tell students, “Since we only have six subgroups, and we need to have at least two subgroups work together per team, we will have panel angle, shading amount, and temperature as our changing variables and set all other variables as class controls (controls that have the same value for the entire class).” Put the *Class Plan* (picture packet, page 4) under the document camera. Tell students, “We will now determine the values for our class controls.” Lead students to select light

distance/14 cm (this is the length of the spacing tool which makes it easiest to set up the experiment) and record this under *Class Controls* on the Class Plan.

Tell students, “We will now form teams to investigate the other variables. Within your subgroup, rank the changing variables from most interested in investigating to least interested in investigating.” Give subgroups approximately 2 minutes to rank their choice of variable. Then, use the fair sticks (in the lead box) to select subgroups to choose the team they will join. Record which subgroups will be in which teams by checking each subgroup’s box on the *Class Plan* as they select their teams. As you record this on the *Class Plan* page, have students record their team on the top of page 20. Make sure subgroups are evenly distributed between teams. An example filled out *Class Plan* is shown below (left).

CLASS PLAN

Subgroup: The original people you worked with.

Team: Multiple subgroups that are investigating the same changing variable.

Class Control: A control that everyone in the class has the same value for.

- The class picks this value together.

Team Control: A control that everyone in a team has the same value for, but values vary for different teams within a class.

- Teams pick this value together.

Subgroup Control: A control that everyone in a subgroup has the same value for, but values vary for different subgroups within a team.

- Subgroups pick this value on their own, with team input.

Changing Variable: The variable that is purposely changed in an experiment.

- Each subgroup picks multiple values on their own

Class Control

Light Height / 14 cm

Team Panel Angle

Orange 1 Blue 1 Green 1

Orange 2 Blue 2 Green 2

Team Shading Amount

Orange 1 Blue 1 Green 1

Orange 2 Blue 2 Green 2

Team Temperature

Orange 1 Blue 1 Green 1

Orange 2 Blue 2 Green 2

Picture Packet, Page 4

4

Our subgroup is on team: Shading amount

Variables	Min Value	Max Value
Panel Angle:	30°	75°
Shading Amount:	0	8
Temperature:	19°C	44°C

The range for our changing variable is:

$$\text{range} = \text{max value} - \text{min value}$$

$$8/8 - 0/8 = 8/8 = 1$$

- As a subgroup select and record the values of your changing variable in the table below.

Team Temperature: Choose any whole number temperatures between 25°C and 44°C. You may also choose room temperature (ranges from 19°C - 24°C) as one of your four values. If you select this value, write “RT” on the line; you will record the numerical value of the room temperature and determine the percent temperature on the experiment day.
- Use the following equation to calculate the percent of your change variable values.

$$\% \text{ changing variable} = 100 \times \left(\frac{\text{value} - \text{min value}}{\text{range}} \right)$$

1) Changing Variable Value 1: <u>0/8</u>	2) Changing Variable Value 2: <u>4/8</u>
% Changing Variable =	% Changing Variable =
$100 \times \left(\frac{0/8 - 0/8}{1} \right) = 0\%$	$100 \times \left(\frac{4/8 - 0/8}{1} \right) = 50\%$
3) Changing Variable Value 3: <u>6/8</u>	4) Changing Variable Value 4: <u>8/8</u>
% Changing Variable =	% Changing Variable =
$100 \times \left(\frac{6/8 - 0/8}{1} \right) = 75\%$	$100 \times \left(\frac{8/8 - 0/8}{1} \right) = 100\%$

20

Tell students, “Before we get into our teams, you are going to select the values of your changing variable and then turn these values into percentages.” Show students where to calculate the range of their changing variable, write the changing variable values they selected, and where to calculate the percentage of their changing variables on page 20 of their notebook. Tell team temperature, “The lowest temperature you can choose is room temperature, which is between 19°C and 24°C. All of your other temperature selections must be higher than 24°C. To select room temperature, write RT on the line. You will not be able to calculate the percentage of room temperature until the experiment day, when you can measure the room temperature.” Have the subgroup calculate their changing variable percentages while the mentors walk around and help. An example notebook page is shown above (right).

Team Plan Discussion:

(7 minutes – Teams – SciTrek Mentors)

Have subgroups find their teams and sit with them and their mentor(s). Give each team their team plan.

Help your team fill out the team plan, given to you by the lead. First, have each of the subgroups on your team choose one of the two symbols. Write the subgroup color and number next to the symbol they

select (Ex: Δ Green 2). Then have student write their team and symbol on the front cover of their notebook.

Tell students, “Each subgroup will now get to choose their subgroup control value.” Ask students, “Should our subgroup control values be close to, or far apart from, each other and why?” Possible student response: they should be spread out, which will help us see how changing the subgroup control affects the power produced by a solar panel.” Have each subgroup select their subgroup control values, and write the value next to the symbol. For team’s temperature and panel angle, have the team members select their team control value.

Hold onto the team plan to help the subgroups on your team fill out their experimental set ups later today. An example filled out team plan is shown below. Each team has a slightly different team plan; examples of all team plans are shown below.

<p style="text-align: center;">TEAM SHADING AMOUNT TEAM PLAN</p> <p>1) Write each subgroups' color and number (found on notebook cover) next to one of the symbols (O or Δ).</p> <p>Subgroup Symbol:</p> <p style="text-align: center;"> \circ <u>Blue 2</u> <small>Subgroup</small> Δ <u>Green 2</u> <small>Subgroup</small> </p> <p>2) On the front cover of your notebook for Team/Subgroup Symbol, fill in “Shading”/ the symbol for your subgroup from 1.</p> <p>3) Your subgroup control will be panel angle. As a subgroup, select the values you will use.</p> <p>Panel Angle: Choose any panel angle between 30° and 75° (original = 45°).</p> <p style="text-align: center;">\circ <u>30°C</u> Δ <u>75°C</u></p> <p>4) Your teams' team control will be temperature. The value you will use will be room temperature (RT). This will be a temperature between 19°C - 26°C. You will record the numerical value of room temperature on experiment day.</p> <p style="text-align: center;">Temperature: <u>RT</u></p> <p>5) The class control will be light height.</p> <p style="text-align: center;">Light Height: <u>14 cm</u></p> <div style="text-align: center; border: 1px solid black; padding: 5px; width: fit-content; margin: 0 auto;"> Example Team Plan </div>	<table border="1" style="width: 100%; border-collapse: collapse;"> <tr> <td style="width: 50%; padding: 5px; vertical-align: top;"> <p style="text-align: center;">TEAM PANEL ANGLE TEAM PLAN</p> <p>1) Write each subgroup' color and number (found on notebook cover) next to one of the symbols.</p> <p>Subgroup Symbol:</p> <p style="text-align: center;"> \circ <u>Orange 1</u> <small>Subgroup</small> Δ <u>Green 1</u> <small>Subgroup</small> </p> <p>2) On the front cover of your notebook for Team/Subgroup Symbol, fill in “Panel Angle” the symbol for your subgroup from 1.</p> <p>3) Your subgroup control will be temperature. As a subgroup, select the values you will use.</p> <p>temperature: Choose any whole number temperature between 30°C and 44°C. You may also choose room temperature (origins from 19°C - 26°C). If you select this value, write “RT” on the line. You will record the numerical value of room temperature on experiment day.</p> <p style="text-align: center;">\circ <u>RT</u> Δ <u>40°C</u></p> <p>4) Your teams' team control will be shading amount. As a team, select the value you will use.</p> <p>Shading Amount: Choose any fraction from $\frac{1}{4}$ to $\frac{3}{4}$ (original = $\frac{1}{2}$).</p> <p style="text-align: center;">$\frac{1}{4}$</p> <p>5) The class control will be light height.</p> <p style="text-align: center;">Light Height: <u>14 cm</u></p> <div style="text-align: center; border: 1px solid black; padding: 5px; width: fit-content; margin: 0 auto;"> Other Team Plans </div> </td> <td style="width: 50%; padding: 5px; vertical-align: top;"> <p style="text-align: center;">TEAM TEMPERATURE TEAM PLAN</p> <p>1) Write each subgroup' color and number (found on notebook cover) next to one of the symbols.</p> <p>Subgroup Symbol:</p> <p style="text-align: center;"> \circ <u>Orange 2</u> <small>Subgroup</small> Δ <u>Blue 1</u> <small>Subgroup</small> </p> <p>2) On the front cover of your notebook for Team/Subgroup Symbol, fill in “Temp” the symbol for your subgroup from 1.</p> <p>3) Your subgroup control will be shading amount. As a subgroup, select the values you will use.</p> <p>Shading Amount: Choose any fraction from $\frac{1}{4}$ to $\frac{3}{4}$ (original = $\frac{1}{2}$).</p> <p style="text-align: center;">$\frac{1}{4}$ $\frac{1}{2}$ $\frac{3}{4}$</p> <p>4) Your teams' team control will be panel angle. As a team, select the value you will use.</p> <p>Panel Angle: Choose any angle between 30° and 75° (original = 45°).</p> <p style="text-align: center;"><u>45°</u></p> <p>5) The class control will be light height.</p> <p style="text-align: center;">Light Height: <u>14 cm</u></p> </td> </tr> </table>	<p style="text-align: center;">TEAM PANEL ANGLE TEAM PLAN</p> <p>1) Write each subgroup' color and number (found on notebook cover) next to one of the symbols.</p> <p>Subgroup Symbol:</p> <p style="text-align: center;"> \circ <u>Orange 1</u> <small>Subgroup</small> Δ <u>Green 1</u> <small>Subgroup</small> </p> <p>2) On the front cover of your notebook for Team/Subgroup Symbol, fill in “Panel Angle” the symbol for your subgroup from 1.</p> <p>3) Your subgroup control will be temperature. As a subgroup, select the values you will use.</p> <p>temperature: Choose any whole number temperature between 30°C and 44°C. You may also choose room temperature (origins from 19°C - 26°C). If you select this value, write “RT” on the line. You will record the numerical value of room temperature on experiment day.</p> <p style="text-align: center;">\circ <u>RT</u> Δ <u>40°C</u></p> <p>4) Your teams' team control will be shading amount. As a team, select the value you will use.</p> <p>Shading Amount: Choose any fraction from $\frac{1}{4}$ to $\frac{3}{4}$ (original = $\frac{1}{2}$).</p> <p style="text-align: center;">$\frac{1}{4}$</p> <p>5) The class control will be light height.</p> <p style="text-align: center;">Light Height: <u>14 cm</u></p> <div style="text-align: center; border: 1px solid black; padding: 5px; width: fit-content; margin: 0 auto;"> Other Team Plans </div>	<p style="text-align: center;">TEAM TEMPERATURE TEAM PLAN</p> <p>1) Write each subgroup' color and number (found on notebook cover) next to one of the symbols.</p> <p>Subgroup Symbol:</p> <p style="text-align: center;"> \circ <u>Orange 2</u> <small>Subgroup</small> Δ <u>Blue 1</u> <small>Subgroup</small> </p> <p>2) On the front cover of your notebook for Team/Subgroup Symbol, fill in “Temp” the symbol for your subgroup from 1.</p> <p>3) Your subgroup control will be shading amount. As a subgroup, select the values you will use.</p> <p>Shading Amount: Choose any fraction from $\frac{1}{4}$ to $\frac{3}{4}$ (original = $\frac{1}{2}$).</p> <p style="text-align: center;">$\frac{1}{4}$ $\frac{1}{2}$ $\frac{3}{4}$</p> <p>4) Your teams' team control will be panel angle. As a team, select the value you will use.</p> <p>Panel Angle: Choose any angle between 30° and 75° (original = 45°).</p> <p style="text-align: center;"><u>45°</u></p> <p>5) The class control will be light height.</p> <p style="text-align: center;">Light Height: <u>14 cm</u></p>
<p style="text-align: center;">TEAM PANEL ANGLE TEAM PLAN</p> <p>1) Write each subgroup' color and number (found on notebook cover) next to one of the symbols.</p> <p>Subgroup Symbol:</p> <p style="text-align: center;"> \circ <u>Orange 1</u> <small>Subgroup</small> Δ <u>Green 1</u> <small>Subgroup</small> </p> <p>2) On the front cover of your notebook for Team/Subgroup Symbol, fill in “Panel Angle” the symbol for your subgroup from 1.</p> <p>3) Your subgroup control will be temperature. As a subgroup, select the values you will use.</p> <p>temperature: Choose any whole number temperature between 30°C and 44°C. You may also choose room temperature (origins from 19°C - 26°C). If you select this value, write “RT” on the line. You will record the numerical value of room temperature on experiment day.</p> <p style="text-align: center;">\circ <u>RT</u> Δ <u>40°C</u></p> <p>4) Your teams' team control will be shading amount. As a team, select the value you will use.</p> <p>Shading Amount: Choose any fraction from $\frac{1}{4}$ to $\frac{3}{4}$ (original = $\frac{1}{2}$).</p> <p style="text-align: center;">$\frac{1}{4}$</p> <p>5) The class control will be light height.</p> <p style="text-align: center;">Light Height: <u>14 cm</u></p> <div style="text-align: center; border: 1px solid black; padding: 5px; width: fit-content; margin: 0 auto;"> Other Team Plans </div>	<p style="text-align: center;">TEAM TEMPERATURE TEAM PLAN</p> <p>1) Write each subgroup' color and number (found on notebook cover) next to one of the symbols.</p> <p>Subgroup Symbol:</p> <p style="text-align: center;"> \circ <u>Orange 2</u> <small>Subgroup</small> Δ <u>Blue 1</u> <small>Subgroup</small> </p> <p>2) On the front cover of your notebook for Team/Subgroup Symbol, fill in “Temp” the symbol for your subgroup from 1.</p> <p>3) Your subgroup control will be shading amount. As a subgroup, select the values you will use.</p> <p>Shading Amount: Choose any fraction from $\frac{1}{4}$ to $\frac{3}{4}$ (original = $\frac{1}{2}$).</p> <p style="text-align: center;">$\frac{1}{4}$ $\frac{1}{2}$ $\frac{3}{4}$</p> <p>4) Your teams' team control will be panel angle. As a team, select the value you will use.</p> <p>Panel Angle: Choose any angle between 30° and 75° (original = 45°).</p> <p style="text-align: center;"><u>45°</u></p> <p>5) The class control will be light height.</p> <p style="text-align: center;">Light Height: <u>14 cm</u></p>		

Question:

(5 minutes – Teams – SciTrek Mentors)

Ask your team, “What changing variable are we investigating?” If needed, refer to your team plan page. Then, ask your team, “What will we be measuring?” Students should reply, “Amount of power produced by a solar panel.” Then have your team fill out their question on page 21.

Students will now split into their subgroups to complete the experimental set-up, procedure, and results table.

QUESTION

Question our subgroup will investigate:

- If we change the shading amount,
insert each changing variable (independent variable)
 what will happen to the power produced by the solar
insert what you are calculating
panel?

EXPERIMENTAL SET-UP

Write your changing variable(s) (Ex: panel angle) and the values (Ex: 45°) you will use for your trials under each solar panel.

Changing Variable(s):

1) Shading Amount: 0/8 4/8 6/8 8/8

2) _____ : _____

Why did your subgroup choose these values of the changing variable? We spread out our changing variable values so our data points will also be spread out.

Controls (variables you will hold constant):
 Write your controls and the values you will use in all your trials (control/value, Ex: power source/solar panel).

Class and Team Controls: <small>(same values between subgroups)</small>	Subgroup Control: <small>(different values between subgroups)</small>
Power Source Solar Panel	Panel Angle 30°
Temperature RT	
Light Height 14 cm	

SciTrek Member Approval: SL

21

Experimental Set-Up:

(5 minutes – Subgroups – SciTrek Mentors)

Have subgroups fill in their experimental set-ups (notebook, page 21). If needed, you can let them look at page 20 of their notebook and the team plan. An example filled-out experimental set-up is shown above. When you sign off on their experimental set-up, ensure all students within a subgroup have the same trial letters, corresponding to the same changing variable values. An example filled-out experiment set up is seen above.

Procedure:

(11 minutes – Subgroups – SciTrek Mentors)

After each subgroup has filled out their experimental set-up, they can start on their procedure (notebook, page 22). Make sure students within the same subgroup are collaborating to write their procedure. Keep procedures as brief as possible, while still conveying the pertinent information (control values, changing variable values, the data they will collect, and what they will calculate) about the experiment. An example step for a subgroup who had panel angle as a changing variable would be: “Place the panel at an angle of D) 30°, E) 45°, F) 60°, and G) 75°.” Some subgroups may struggle with writing a procedure. If they are struggling, tell them to look back at their initial procedure on page 7 of their notebooks. If they are still having trouble, you can have these subgroups dictate each step while you transcribe them onto a notepad found in your group box. Give this sheet to the students to copy into their notebooks. Once students have finished, they should raise their hands and get their procedures approved by their mentor. An example filled out procedure is shown below (left).

Note: 6th grade students are more independent, therefore, students in each subgroup may vary the wording in their procedures. This is fine as long as the steps are in the same order, and the correct values are included in the same steps.

PROCEDURE

Procedure Note:
Make sure to include all values of your changing variable(s) in the procedure. Ex: For a subgroup that decided to change panel angle one step would be: Place the panel at an angle of D) 30°, E) 45°, F) 60°, and G) 75°.

- Set up lamp using the spacing tool 14 cm above panel.
- Place shading tool on solar panel at D) 0/8, E) 4/8, F) 6/8, and G) 8/8 shaded.
- Place the panel at an 30° angle.
- Position panel directly under lamp, and turn lamp on.
- Do not heat the solar panel, leave at RT.
- Use multimeter to measure the current (mA) and voltage (V).
- Calculate the power by multiplying current and voltage.
-

SciTrek Member Approval: SL

22

RESULTS

Table

Check the box of your subgroup control and write your subgroup symbol on the line. Then, fill out the table for each of your trials. For the variables that remain constant, write the value in Trial D. Then, draw an arrow through each box indicating the variable is a control. Remember to record measurements to the nearest tenth (Ex. 4.1 mA), calculate power to the nearest tenth (Ex. 13.2 mW), and percentages to the nearest whole number (Ex. 75%).

Subgroup Control: Panel Angle Shading Amount Temperature Subgroup Symbol: 0

Variables	Trial D	Trial E	Trial F	Trial G
Power Source:	Solar panel	→		
Panel Angle:	30°	→		
Shading Amount:	0/8	4/8	6/8	8/8
Temperature:	→			
Room Temp: 22°C	RT	→		
Light Height:	14 cm	→		
Predictions	Trial D	Trial E	Trial F	Trial G
Put an "S" in the trial that will give the smallest power and an "L" in the trial that will give the largest power.	L			S
Data and Calculations	Trial D	Trial E	Trial F	Trial G
Current (mA):				
Voltage (V):				
Percent Changing Variable: (get values from pg. 20)				
Power (mW): $P = I \times V$				

The independent variable is the changing variable and the dependent variables are the current and voltage.

23

Results Table:

(3 minutes – Subgroups – SciTrek Mentors)

Have students select their subgroup control by checking one of the boxes and writing in their subgroup symbol on the line at the top of page 23. Then, have students underline the variables that are controls, circle the variable that is their changing variable, and box information about data collection. When writing the values make sure for controls, they only write the value of the control in the *Trial D* box, then, draw an arrow through the remaining trials' boxes. For the changing variable, they should write the values in each trial's corresponding box.

When students have finished, have them make predictions about the power produced by the solar panel. Have them write an "S" in the box of the trial they think will produce the smallest power, and an "L" in the box of the trial they think will produce the largest power. They will leave two of the boxes empty. If they think all trials will produce the same power, have them write "same" over all of the boxes. It is okay if the students in a subgroup have different predictions. An example filled-out results table is shown above (right).

Wrap-Up:

(2 minutes – Subgroups – SciTrek Lead)

Tell students, "Next session, you will carry out the experiments you designed today, graph your data on a team graph, and analyze the data to draw conclusions."

Clean-Up:

- Collect notebooks with attached nametags.
- Place materials into your group box and bring them back to UCSB.

Day 6: Experiment/Graph/Conclusion

Schedule:

Introduction (SciTrek Lead) – 9 minutes
 Experiment (SciTrek Mentors) – 20 minutes
 Graph (SciTrek Mentors) – 20 minutes
 Conclusion (SciTrek Mentors) – 9 minutes
 Wrap-Up (SciTrek Lead) – 2 minutes

Materials:

(3) Mentor Boxes:

- | | | |
|---|--|---|
| <input type="checkbox"/> Nametags | <input type="checkbox"/> Mentor lab coat | <input type="checkbox"/> (12) Clear rulers |
| <input type="checkbox"/> Notebooks | <input type="checkbox"/> (2) Pencils | <input type="checkbox"/> (2) Solar panel holders |
| <input type="checkbox"/> Mentor instructions | <input type="checkbox"/> (2) Red pens | <input type="checkbox"/> Filled out team plan |
| <input type="checkbox"/> Picture of experimental set-up | | |
| (2) Ziploc bags (gallon size), with the following: | | |
| <input type="checkbox"/> Protractor | <input type="checkbox"/> Multimeter | <input type="checkbox"/> Shading tool |
| <input type="checkbox"/> Solar panel | <input type="checkbox"/> Spacing tool | <input type="checkbox"/> (2) Binder clips (15 mm) |
| <input type="checkbox"/> IR thermometer | | |

Other Supplies:

- | | | |
|--|---|---|
| <input type="checkbox"/> (2) Boxes of (4) lamps with (4) extension cords | <input type="checkbox"/> Calculator box | <input type="checkbox"/> Box with (6) hair dryers |
|--|---|---|

Lead Box:

- | | | |
|---|--|---|
| <input type="checkbox"/> (3) Extra notebooks | <input type="checkbox"/> (2) Pencils | <input type="checkbox"/> (2) Solar panels |
| <input type="checkbox"/> Lead instructions | <input type="checkbox"/> (2) Red pens | <input type="checkbox"/> Solar panel holder |
| <input type="checkbox"/> Solar Power picture packet | <input type="checkbox"/> (2) Wet erase markers | <input type="checkbox"/> IR thermometer |
| <input type="checkbox"/> Picture of experimental set-up | <input type="checkbox"/> (2) Black pens | <input type="checkbox"/> (2) Multimeters |
| <input type="checkbox"/> Lead lab coat | <input type="checkbox"/> (5) Clear rulers | <input type="checkbox"/> Shading tool |
| <input type="checkbox"/> Time card | <input type="checkbox"/> (3) Protractors | <input type="checkbox"/> (2) Binder clips (15 mm) |

Notebook Pages:

RESULTS Table

Check the box of your subgroup control and write your subgroup symbol on the line. Then, fill out the table for each of your trials. For the variables that remain constant, write the value in Trial D. Then, draw an arrow through each box indicating the variable is a control. Remember to record measurements to the nearest tenth (Ex. 4.1 mA), calculate power to the nearest tenth (Ex. 13.2 mW), and percentages to the nearest whole number (Ex. 75%).

Subgroup Control: Panel Angle Shading Amount Temperature Subgroup Symbol: 0

Variables	Trial D	Trial E	Trial F	Trial G
Power Source:	Solar panel			
Panel Angle:	30°			
Shading Amounts:	0/8	4/8	6/8	8/8
Temperature:				
Room Temp: 22°C	RT			
Light Height:	14 cm			
Predictions	Trial D	Trial E	Trial F	Trial G
Put an "S" in the trial that will give the smallest power and an "L" in the trial that will give the largest power.	L			S
Data and Calculations	Trial D	Trial E	Trial F	Trial G
Current (mA):	5.4 mA	2.9 mA	1.7 mA	0.1 mA
Voltage (V):	2.1 V	1.9 V	1.9 V	0.6 V
Percent Changing Variable: (get values from pg. 20)	0%	50%	75%	100%
Power (mW): $P = I \times V$	$5.4 \text{ mA} \times 2.1 \text{ V} = 11.3 \text{ mW}$	$2.9 \text{ mA} \times 1.9 \text{ V} = 5.5 \text{ mW}$	$1.7 \text{ mA} \times 1.9 \text{ V} = 3.2 \text{ mW}$	$0.1 \text{ mA} \times 0.6 \text{ V} = 0.1 \text{ mW}$

The independent variable is the changing variable and the dependent variables are the current and voltage.

23

Underline controls, circle changing variables, and box information about data collection.

RESULTS Graph

Modified Name of Changing Variable: Panel Angle: Percent Angled
Shading Amount: Percent Shaded
Temperature: Percent Heated

Set up your graph. (Check off the steps as you complete them.)

- Write the title for your graph by filling in the blanks.
- Label the y-axis (vertical) with what you calculated, including units (Ex: Power (mW)).
- Label the x-axis (horizontal) with your modified name of changing variable, including units (Ex: Percent Angled (%)).
- Select your subgroup control in the legend by checking the appropriate box. Then, put your subgroup control value next to your subgroup symbol.

Plot your data.

- On the x-axis, circle your 4 changing variable values (as percentages). If a value is not there, write it in.
- Starting with the smallest changing variable value, determine the power, and put your subgroup symbol at the appropriate level. Write the power next to the point.
- Once you have plotted all 4 points, draw a trend line that best fits your data.

Plot the data collected by the other subgroup in your team.

- Complete the legend for the other subgroup by writing their subgroup control value next to their subgroup symbol.
- Graph the other subgroup's 4 points using their symbol as the markers (do not label these points). Then, draw a trend line that best fits their data.

Effects of Shading amount and panel angle on the power

Legend	
Subgroup Control:	
<input checked="" type="checkbox"/> Panel Angle	
<input type="checkbox"/> Shading Amount	
<input type="checkbox"/> Temperature	
Subgroup Symbol	Subgroup Control Value
○	30°
△	75°

24

CONCLUSION

Generate a **claim** about how your changing variable affected your subgroup's results. (Ex: The larger the size of the solar panel the larger the power produced.)

We can conclude when the solar panel is less shaded, more power will be produced

What **data** do you have to support your claim? (Remember to include your measurements and/or observations, not trial letters.)

because when the solar panel was 0/8 shaded (0%), 11.3 mW of power was produced, and when the panel was 8/8 shaded (100%), 0.1 mW of power was produced.

I acted like a scientist when I graphed my results.

TEAM PREDICTIONS

Use your team graph to predict the power for each subgroup if you were to use 55% of your changing variable. Write your predictions in the table below.

Percent Changing Variable:	
55%	
Subgroup Symbol	Prediction
○	3.8 mW
△	1.5 mW

25

Preparation:

SciTrek Lead:

1. Make sure mentors are setting out notebooks.
2. Make sure mentors are setting up for the experiment.
3. Set up the document camera for the Introduction (picture packet, pages 1, 5, and 6; notebook, page 25).

SciTrek Mentors:

1. Set out notebooks/nametags.
2. Plug in lamps into extension cords and cords into wall. Place them where your subgroups will work.
3. Put solar panel holders, calculators, and bags with supplies, next to the lamps.

Note: Set notebooks where students will sit during the module, even if another student is currently at that desk. If needed, students will move to these spots after the Introduction.

Introduction:

(9 minutes – Full Class – SciTrek Lead)

If students are not in their subgroups, tell them, “A notebook will be put on your desk, which is not your notebook and you should not move it. You will move to your notebook after the Introduction.”

Ask the class, “What is the class question we have been investigating?” Students should reply, “What variables affect the power produced by a solar panel?” Tell students, “Today you are going to perform your second experiment. Once the experiment is complete, you will plot your data on a team graph and analyze it, in order to determine what conclusions can be drawn from your results. Your conclusions will help us answer the class question.”

Tell students, “Once you have collected your data, you will display your measurements on a graph.” Show them how to make a graph using the example data. Display the example results table (picture packet, page 1; shown below [left]), on the document camera. Tell students, “For this example experiment, the question was, ‘If we change the power source, what will happen to the amount of power produced by the solar panels?’” Switch to page 5 of the picture packet, and point to the checklist at the top (also on page 24 of the notebooks). Tell students, “In order to make a graph, you will need to follow the checklist shown on this page.”

Go through the checklist and use the results table in the picture packet to show the students how to set up the graph as well as how the data points were graphed.

Set up your graph. (Check off the steps as you complete them.)

Tell students, “First, before we can plot the data, we need to set up the graph.”

- Write the title for your graph by filling in the blanks.*

Looking at the example results table (picture packet, page 1), ask students, “What was the changing variable?” They should reply, “Power source.” Tell them, “This is why they put power source in the first blank of the graph title.”

Tell students, “In the second blank, we need to fill in the subgroup control. Looking at the top of the results table, what is checked as the subgroup control, for this experiment?” Students should reply, “Panel angle.” Tell them, “This is why they put panel angle in the second blank of the graph title.”

Tell students, “In the third blank, we need to fill in what was calculated. Then, ask students, “What are we calculating in the experiment?” They should reply, “Power.” Tell them, “This is why they put power in the third blank of the graph title.”

- Label the y-axis (vertical) with what you calculated, including units (Ex: power (mW)).*
Show students where this is done on the graph.
- Label the x-axis (horizontal) with your modified name of changing variable, including unit (Ex: Percent Angled (%)).*
Show students the table in the upper right-hand corner of the page with the modified changing variable names. Then, show students where this was recorded on the x-axis.
- Select your subgroup control in the legend by checking the appropriate box. Then, put your subgroup control value next to your subgroup symbol.*
Direct students’ attention to the legend. Remind students the example’s subgroup control was panel angle, and show them where they checked the box for panel angle. Tell students, “Your subgroup symbol should be on the results table (show them, picture packet, page 1), and on the front of your notebook. For this subgroup, their symbol was triangle. Refer to the results table, and ask students, “What value for panel angle did this subgroup use?” Students should reply, “50°.” Then, show students where this information was recorded in the legend.

Plot your Data:

Tell students, “Once your graph is set up, you will be able to plot the data.”

- On the x-axis, circle your 4 changing variable values (as percentages). If a value is not there, write it in.*
Refer to the results table. Ask students, “What is the first changing variable value, and what percent of that changing variable is it?” Students should reply, “One panel which is 25%.” Show students where this was written in and circled on the graph. Ask students, “What is the second changing variable value, and what percent of that changing variable is it?” Students should reply, “Two panels which is 50%.” Show students where it was circled on the graph.
- Starting with the smallest changing variable value, determine the power, and put your subgroup symbol at the appropriate level. Write the power next to the point.*
Ask students, “What was the power when the percent of power sources was 25%?” Students should reply, “9.9 mW.” Show students how 9.9 mW was graphed, using the subgroup symbol, and that the value was written next to it.
- Once you have plotted all 4 points, draw a trend line that best fits your data.*
Tell students, “When you draw a trend line, you will use the clear rulers, and you should extend your trend line to both sides of the graph, as is shown in this example.

RESULTS
Table

Check the box of your subgroup control and write your subgroup symbol on the line. Then, fill out the chart for each of your trials. For the variables that remain constant, write the value in trial E and then draw an arrow through each box indicating that this variable is a control. Remember to record data measurements to the nearest tenth (Ex. 4.1 mA), calculate power to the nearest tenth (Ex. 13.2 mW), and percentages to the nearest whole number (Ex. 75%).

Subgroup Control: Panel Angle Shading Amount Temperature Subgroup Symbol: Δ

Variables	Trial D	Trial E	Trial F	Trial G
Power Source	1 solar panel	2 solar panel	3 solar panel	4 solar panel
Panel Angle:	50°	→		
Shading:	0/8	→		
Temperature:	→			
Room Temp: 22°C	RT	→		
Light Source:	Lamp	→		
Predictions	Trial E	Trial F	Trial G	Trial H
other variable:	L			S
Data and Calculations	Trial D	Trial E	Trial F	Trial G
Current (mA):	5.2 mA	6.0 mA	6.7 mA	7.7 mA
Voltage (V):	1.9 V	1.9 V	2.0 V	2.0 V
Percent CV: (get values from pg. 20)	25%	50%	75%	100%
Power (mW): $P = I \times V$	$5.2 \text{ mA} \times 1.9 \text{ V} = 9.9 \text{ mW}$	$6.0 \text{ mA} \times 1.9 \text{ V} = 11.4 \text{ mW}$	$6.7 \text{ mA} \times 2.0 \text{ V} = 13.4 \text{ mW}$	$7.7 \text{ mA} \times 2.0 \text{ V} = 15.4 \text{ mW}$

The independent variable is the changing variable and the dependent variables are the current and voltage.

Picture Packet, Page 1

RESULTS
Graph

Modified Name of Changing Variable:
 Panel Angle: Percent Angled
 Shading Amount: Percent Shaded
 Temperature: Percent Heated

Set up your graph. (Check off the steps as you complete them.)

- Write the title for your graph by filling in the blanks.
- Label the y-axis (vertical) with what you calculated, including units (Ex: Power (mW)).
- Label the x-axis (horizontal) with your modified name of changing variable, including units (Ex: Percent Angled (%)).
- Select your subgroup control in the legend by checking the appropriate box. Then, put your subgroup control value next to your subgroup symbol.

Plot your data.

- On the x-axis, circle your 4 changing variable values (as percentages). If a value is not there, write it in.
- Starting with the smallest changing variable value, determine the power, and put your subgroup symbol at the appropriate level. Write the power next to the point.
- Once you have plotted all 4 points, draw a trend line that best fits your data.

Plot the data collected by the other subgroup in your team.

- Complete the legend for the other subgroup in your team by writing their subgroup control value next to their subgroup symbol.
- Graph the other subgroup's 4 points using their symbol as the markers (do not label these points). Then, draw a trend line that best fits their data.

Effects of power source and panel angle on the power

Picture Packet, Page 5

Plot the data collected by the other subgroups in your team.

Tell students, "Once you finish graphing your own data, you should have it checked by a mentor. After, you will ask the other subgroup on your team for their data, and graph it using the following steps."

- Complete the legend for the other subgroup in your team by writing their subgroup control value next to their subgroup symbol.
- Graph the other subgroup's 4 points using their symbol as the markers (do not label these points). Then, draw a trend line that best fits their data.

Once students have finished their graphs, they should have two trend lines on their graph, showing the data for both subgroups on their team. Show students the completed team graph (picture packet, page 6). Point out that on the completed team graph, the legend is completely filled out and all data points are marked with the symbol of the group that collected the data.

Modified Name of Changing Variable:
 Panel Angle: Percent Angled
 Shading Amount: Percent Shaded
 Temperature: Percent Heated

RESULTS Graph

Set up your graph. (Check off the steps as you complete them.)

- Write the title for your graph by filling in the blanks.
- Label the y-axis (vertical) with what you calculated, including units (Ex: Power (mW)).
- Label the x-axis (horizontal) with your modified name of changing variable, including units (Ex: Percent Angled (%)).
- Select your subgroup control in the legend by checking the appropriate box. Then, put your subgroup control value next to your subgroup symbol.

Plot your data.

- On the x-axis, circle your 4 changing variable values (as percentages). If a value is not there, write it in.
- Starting with the smallest changing variable value, determine the power, and put your subgroup symbol at the appropriate level. Write the power next to the point.
- Once you have plotted all 4 points, draw a trend line that best fits your data.

Plot the data collected by the other subgroup in your team.

- Complete the legend for the other subgroup in your team by writing their subgroup control value next to their subgroup symbol.
- Graph the subgroup's 4 points using their symbol as the markers (do not label these points). Then, draw trend line that best fits their data.

Effects of power source and panel angle
on the power

Legend	
Subgroup Control:	
<input checked="" type="checkbox"/>	Panel Angle
<input type="checkbox"/>	Shading Amount
<input type="checkbox"/>	Temperature
Subgroup Symbol	Subgroup Control Value
○	30°
△	50°

Picture Packet, Page 6

6

Tell students, “Once you finish graphing your team results, you should draw conclusions from your results.” Ask students, “How do scientists define a conclusion?” Students should reply, “A claim supported by data.” Ask students, “What is a claim?” Students should reply, “A statement that can be tested.” Ask students “What can be used for data?” Students should reply, “Measurements, observations, or calculations.”

Tell students, “Since we are acting like engineers and engineers would try to maximize the amount of power produce, our claim should be focused on producing the most power. Additionally, you need to refer to your entire team graph for the claim, to verify the trend was the same for both subgroups. When coming up with the supporting data for your claim, refer only to your specific subgroup’s data for values.” Put the completed team graph, under the document camera (picture packet, page 6; shown above). Ask students, “Based on this team’s data, what happens to the power when the percentage of power source increases?” Possible student response: as the percentage of power sources increases, more power is produced. Write this claim into the class notebook in the claim section of the conclusions on page 25. Tell students, “You should use two data points to support your claim.” Ask students, “Which two data points are the most convincing for this claim?” Possible student response: the smallest and largest values of the power. Tell students, “When you are writing your data statements, you should include the percentage of your changing variable and the value of your changing variable.” Ask students, “What should our data statement be?” Possible student response: when 4 panels was used (100%), 15.4 mW of power was produced, and when 1 panel was used (25%), 9.9 mW of power was produced. Write this data statement in the class notebook, under the data section of the conclusions on page 25. An example is shown below.

CONCLUSION

Generate a claim about how your changing variable affected your team's results. (Ex: The larger the size of the solar panel the larger the power produced.)

We can conclude as the percentage of power
sources increases, more power is
produced by the solar panel.

What data do you have to support your claim? (Remember to include your calculations, not trial letters.)

because when 4 panels was used (100%),
15.4 mW of power was produced, and
when 1 panel was used (25%), 9.9 mW
of power was produced.

I acted like a scientist when _____

TEAM PREDICTIONS

Use your team graph to predict the power for each subgroup if you were to use 55% of your changing variable. Write your predictions in the table below.

Percent Changing Variable:	
55%	
Subgroup Symbol	Prediction
○	
△	

25

Remind students of the following things before allowing them to start their experiments.

- Connect the multimeter to the solar panel by connecting the red wires together and black wires together making sure red and black wires do not touch.
- Position the solar panel so the arrow is pointed up.
- Position the solar panel holder so the word SciTrek is right side up when looking at the holder.
- Shading amount increases from the bottom of the solar panel ($\frac{0}{8}$) to the top of the solar panel ($\frac{8}{8}$).
- Use the clear scale of the protractor.
- Take and record room temperature before starting the experiment.
 - Do not point the laser at anything except the solar panel and the ceiling (ceiling used to get room temperature).
- Heat the solar panel by turning the hair dryer on high, holding it about 6 inches from the panel, and moving it back and forth for about 10 seconds. Then, check the temperature. Repeat the process until the panel is about 2°C above the target temperature and make the current and voltage measurements as the panel cools down. above their goal temperature and wait for the panel to cool down before taking their measurements.
 - Make sure the thermometer and the solar panel are 90° to each other and point the laser at the dot on the panel or the shading tool.
 - For Team Temperature, if there is a trial at room temperature, do that first.
- Rotate between roles of thermometer reader, hair dryer operator, multimeter reader, and recorder between trials.
- Start with the multimeter on the setting boxed in black to measure the current, then flip to the setting boxed in silver to measure the voltage.
- Multiple the current and the voltage to get the power and record it to the nearest tenths place.

When students are starting their experiments, flip the picture packet to page 1 to show them the properly filled out results table. When students are ready to start their graphs, flip the picture packet to page 6 to show them a properly filled out graph.

Experiment:

(20 minutes – Subgroups – SciTrek Mentors)

Give students their requested materials. If students are missing any of their experimental materials, the lead box has extra materials. Have your subgroups show you their first set-up so you can approve it before moving on. Verify they have the correct angle of their solar panel and are using the clear scale of the protractor. If you have a subgroup using a temperature other than room temperature, stay and observe their first trial to make sure it runs smoothly. If temperature is a subgroup control, the subgroup should heat their panel to 2°C above their goal temperature and allow the panel to cool before recording the current and voltage. If temperature is the changing variable and they have a room temperature trial, have them do the room temperature trial first. Then they should heat the solar panel to the maximum temperature and take the current and voltage readings as the panel cools down. Make sure students have assigned themselves roles (thermometer reader, hair dryer operator, multimeter reader, or recorder) and know to rotate these roles between trials. Remind subgroups that they will read the current from the setting boxed in black on the multimeter, and the voltage from the setting boxed in silver.

Students should record the current and voltage during each trial, but have them wait until they have finished the entire experiment to calculate the powers for each trial. Allow students to keep their materials on their desks until they finish graphing their results. If there is extra time, they may repeat any trials to check their results. If your team has things under control, help other subgroups. An example filled out results table is shown below (left).

RESULTS Table

Check the box of your subgroup control and write your subgroup symbol on the line. Then, fill out the table for each of your trials. For the variables that remain constant, write the value in Trial D. Then, draw an arrow through each box indicating the variable is a control. Remember to record measurements to the nearest tenth (Ex. 4.1 mA), calculate power to the nearest tenth (Ex. 13.2 mW), and percentages to the nearest whole number (Ex. 75%).

Subgroup Control: Panel Angle Shading Amount Temperature Subgroup Symbol: 0

Variables	Trial D	Trial E	Trial F	Trial G
Power Source:	Solar panel			
Panel Angle:	30°			
Shading Amounts:	0/8	4/8	6/8	8/8
Temperature:				
Room Temp: 22°C	RT			
Light Height:	14 cm			
Predictions	Trial D	Trial E	Trial F	Trial G
Put an "S" in the trial that will give the smallest power and an "L" in the trial that will give the largest power.	L			S
Data and Calculations	Trial D	Trial E	Trial F	Trial G
Current (mA):	5.4 mA	2.9 mA	1.7 mA	0.1 mA
Voltage (V):	2.1 V	1.9 V	1.9 V	0.6 V
Percent Changing Variable: (get values from pg. 20)	0%	50%	75%	100%
Power (mW): $P = I \times V$	$5.4 \text{ mA} \times 2.1 \text{ V} = 11.3 \text{ mW}$	$2.9 \text{ mA} \times 1.9 \text{ V} = 5.5 \text{ mW}$	$1.7 \text{ mA} \times 1.9 \text{ V} = 3.2 \text{ mW}$	$0.1 \text{ mA} \times 0.6 \text{ V} = 0.1 \text{ mW}$

The independent variable is the changing variable and the dependent variables are the current and voltage.

RESULTS Graph

Modified Name of Changing Variable:
 Panel Angle: Percent Angled
 Shading Amount: Percent Shaded
 Temperature: Percent Heated

Set up your graph. (Check off the steps as you complete them.)

- Write the title for your graph by filling in the blanks.
- Label the y-axis (vertical) with what you calculated, including units (Ex: Power (mW)).
- Label the x-axis (horizontal) with your modified name of changing variable, including units (Ex: Percent Angled (%)).
- Select your subgroup control in the legend by checking the appropriate box. Then, put your subgroup control value next to your subgroup symbol.

Plot your data.

- On the x-axis, circle your 4 changing variable values (as percentages). If a value is not there, write it in.
- Starting with the smallest changing variable value, determine the power, and put your subgroup symbol at the appropriate level. Write the power next to the point.
- Once you have plotted all 4 points, draw a trend line that best fits your data.

Plot the data collected by the other subgroup in your team.

- Complete the legend for the other subgroup in your team by writing their subgroup control value next to their subgroup symbol.
- Graph the other subgroup's 4 points using their symbol as the markers (do not label these points). Then, draw a trend line that best fits their data.

Effects of Shading amount and panel angle on the power

Percent Shaded (%)	Power (mW) - Panel Angle	Power (mW) - Shading Amount
0	11.3	-
50	5.5	5.5
75	3.2	3.2
100	0.1	-

23

Graph:

(17 minutes – Subgroups/Teams – SciTrek Mentors)

Pass out a clear ruler to students who are ready to make their graph. Help subgroups fill out their graphs by having them go through and complete the checklist on page 24. Be sure students write a title for their graph (by filling in the blanks), label the y-axis with “Power (mW),” label the x-axis with the modified name of their changing variable (Ex: Percent Angled), and write their subgroup control value into the legend. Additionally, make sure students circle their changing variable values (as percentages) on the x-axis (as well as write them in if they are not already printed on the axis). Once students have their data plotted, they should draw in a trend line.

Once students have graphed their subgroup’s data, help them graph the data from the other subgroup in their team. Call both subgroups in the team together. Have one subgroup read off their data points, while the other subgroup plots them. Repeat this process, so both subgroups have all of the data plotted on their graphs. Make sure when students are plotting the other subgroup’s data they **do not** write the number values of the power on top of their points, or circle the changing variable values. An example filled out graph is shown above.

If one subgroup is finished before the other one, take a picture (using your cell phone) of the other subgroups data that is not finished and show it to the finished group so they can start plotting their points.

Conclusion:

(9 minutes – Subgroups – SciTrek Mentors)

Have subgroups use their graphs to look for trends in their data. Challenge subgroups to think about how their changing variable did, or did not, affect the power produced by the solar panel.

When writing their conclusions (notebook, page 25), make sure subgroups begin the statement with a claim (statement that can be tested) about the trend or pattern in their data. If their graph shows an increasing or decreasing trend, then that variable affects the power produced by the solar panel. If, on the other hand, their graph showed no trend (a flat line), then that variable did not affect the power produced by the solar panel. Since this is an engineering activity, subgroups’ claims should be focused on the value (or pattern of values) of their changing variable that produced the most power and allows them to make a prediction. An example of an appropriate claim could be: the less shading on the solar panel, the more power is produced. This is an appropriate claim because it allows the students to make a prediction about what would happen if new values of their changing variable were introduced, and identifies which value would produce the most power.

After generating a claim about their experiment, subgroups will put their supporting data after the *because* in their conclusion sentence. Their supporting data should include at least two pieces of data, typically the minimum and maximum power values produced, as well as the corresponding changing variable values (as percentages). Make sure subgroups are using their changing variable values (not trial letters), and specific calculations, to support their claims. The supporting data for the previously mentioned claim would be: when the solar panel was $\frac{0}{8}$ shaded (0%), 11.3 mW of power was produced, and when the panel was $\frac{8}{8}$ shaded (100%), 0.1 mW of power was produced.

Conclusions are still valid, and important, if they show the changing variable tested does not affect the power.

An example filled out conclusion is shown below.

CONCLUSION

Generate a claim about how your changing variable affected your subgroup's results. (Ex: The larger the size of the solar panel the larger the power produced.)

What data do you have to support your claim? (Remember to include your measurements and/or observations, not trial letters.)

We can conclude when the solar panel is less shaded, more power will be produced

because when the solar panel was 0/8 shaded (0%), 11.3 mW of power was produced, and when the panel was 8/8 shaded (100%), 0.1 mW of power was produced.

I acted like a scientist when I graphed my results.

TEAM PREDICTIONS

Use your team graph to predict the power for each subgroup if you were to use 55% of your changing variable. Write your predictions in the table below.

Percent Changing Variables:	
55%	
Subgroup Symbol	Prediction
○	3.8 mW
△	1.5 mW

25

Next, have students fill in the sentence frame (notebook, page 25): *I acted like a scientist when*. Each student's response should be unique and specific. They should **not** write, "when I did an experiment," because this is general and applies to all of the students in the class. If students are having trouble with this sentence frame, ask them, "What did you do during SciTrek?"

If there is time, have students analyze their team graphs to make predictions from each subgroups' data. Students are asked to predict what the power would be if they were to use a changing variable value corresponding to 55%. To get started, have students look at their own data, on the graph, first. They should find 55% on the x-axis, draw a dotted line vertically to their trend line, then, find the predicted power by drawing a second dotted line horizontally across to the y-axis. Students should write their predicted power value next to their subgroup symbol in the chart. Have students repeat this process for the other trend line on their team graph. All values will likely be different.

Wrap-Up:

(2 minutes – Full Class – SciTrek Lead)

Ask students the following questions:

How did you act like a scientist during this project?

What did you do that, scientists do?

After discussing how they acted like scientists, and talking about how everyone does things scientists do in their everyday lives, tell students, "Next session, you will make posters, and present your findings. I am looking forward to hearing about all of your experiments."

Clean-Up:

1. Collect notebooks with attached nametags.
2. Make sure all calculators have a cover on and are placed back into the calculator box.
3. Put lamps, extension cords, and hair dryers, back in their boxes.
4. Place all other materials into your group box and bring them back to UCSB.

Day 7: Poster Making/Poster Presentations

Note: Timing is tight on this day. It is possible the class will only get through two of the three presentations during the allotted time. In this case, the teacher will need to lead the third poster presentation, outside of SciTrek time, before the next SciTrek session.

Schedule:

Introduction (SciTrek Lead) – 2 minutes
 Poster Making (SciTrek Mentors) – 25 minutes
 Practice Posters (SciTrek Mentors) – 5 minutes
 Poster Presentations (SciTrek Mentors/SciTrek Lead) – 26 minutes
 Wrap-Up (SciTrek Lead) – 2 minutes

Materials:

(3) Mentor Boxes:

- | | | |
|--|---|--|
| <input type="checkbox"/> Nametags | <input type="checkbox"/> (2) Pencils | <input type="checkbox"/> (2) Glues |
| <input type="checkbox"/> Notebooks | <input type="checkbox"/> (9) Paperclips | <input type="checkbox"/> (2) Clear rulers |
| <input type="checkbox"/> Mentor instructions | <input type="checkbox"/> (2) Highlighters | <input type="checkbox"/> (12) Sharpened SciTrek pencils (all same color) |
| <input type="checkbox"/> Mentor lab coat | <input type="checkbox"/> Scissors | |
| <input type="checkbox"/> Poster diagram | | |

Other Supplies:

- Poster paper tube

Lead Box:

- | | | |
|--|--|---|
| <input type="checkbox"/> (3) Extra notebooks | <input type="checkbox"/> (2) Stickers on how to present the <i>Graph: Specific</i> | <input type="checkbox"/> (2) Scissors |
| <input type="checkbox"/> Lead instructions | <input type="checkbox"/> (2) Pencils | <input type="checkbox"/> (2) Glues |
| <input type="checkbox"/> Solar Power picture packet | <input type="checkbox"/> (2) Wet erase markers | <input type="checkbox"/> Stapler |
| <input type="checkbox"/> Lead lab coat | <input type="checkbox"/> (2) Black pens | <input type="checkbox"/> (3) Clear rulers |
| <input type="checkbox"/> Poster diagram | <input type="checkbox"/> (9) Paperclips | <input type="checkbox"/> Scotch tape |
| <input type="checkbox"/> Time card | <input type="checkbox"/> (2) Highlighters | <input type="checkbox"/> (1 each color) Poster part packs |
| <input type="checkbox"/> (2) Stickers on how to present the <i>Results Table</i> | | |

Preparation:

At SciTrek

At the SciTrek office prior to going to module a SciTrek staff member will highlight, number, sticker, and staple in the supporting documents for poster presentations. They will use the chart below to ensure all students on the team have a speaking part. If a student is presenting multiple sections, a paperclip will be used to clip those sections together to make it easy for them to flip back and forth between the pages.

Speaking Parts	Notes
<ol style="list-style-type: none"> 1. Scientists' Names 2. Question 3. Experimental Set-Up: General 4. Experimental Set-Up: Specific (<i>Staple presentation sheet into notebook, pg. 21</i>) 5a. Results Table ○ (<i>Sticker, pg. 23</i>) 5b. Results Table Δ (<i>Sticker, pg. 23</i>) 6. Procedure (<i>paperclip instruction sheet to notebook and staple presentation piece into notebook, pg. 22</i>) 7. Graph: General (<i>Staple presentation sheet into notebook, pg. 24</i>) 8. Graph: Specific (<i>Sticker, fill in first blank in sticker, pg. 24</i>) 9. Conclusion 	<p>*Students highlighted in gray must be from the same subgroup (the subgroup with the most convincing data).</p> <p>*All students should have a speaking part. Depending on the size of the team it might be necessary to have students present more than one speaking part or divide speaking parts into two (Ex: two people present the procedure).</p>

#1 The scientists in our team are _____.

#2 QUESTION

Question our subgroup will investigate:

- If we change the shading amount _____, what will happen to the power produced by the solar panel _____?

EXPERIMENTAL SET-UP

Write your changing variable(s) (Ex: panel angle) and the values (Ex: 45°) you will use for your trials under each solar panel.

	D	E	F	G
Changing Variable(s):				
Shading Amount:	0/8	4/8	6/8	8/8

Why did your subgroup choose these values of the changing variable? We spread out our changing variable values so our data points will also be spread out.

Controls (variables you will hold constant):
Write your controls and the values you will use in all your trials (control value, Ex: power source/solar panel).

Class and Team Controls (same values between subgroups)		Subgroup Control (different values between subgroups)	
Power Source / Solar Panel	Panel Angle / 30°		
Temperature / RT			
Light Height / 14 cm			

SciTrek Member Approval: _____

QUESTION

Question our subgroup will investigate:

- If we change the shading amount _____, what will happen to the power produced by the solar panel _____?

#3 EXPERIMENTAL SET-UP

Write your changing variable(s) (Ex: panel angle) and the values (Ex: 45°) you will use for your trials under each solar panel.

	D	E	F	G
Changing Variable(s):				
Shading Amount:	0/8	4/8	6/8	8/8

Why did your subgroup choose these values of the changing variable? We spread out our changing variable values so our data points will also be spread out.

Controls (variables you will hold constant):
Write your controls and the values you will use in all your trials (control value, Ex: power source/solar panel).

Class and Team Controls (same values between subgroups)		Subgroup Control (different values between subgroups)	
Power Source / Solar Panel	Panel Angle / 30°		
Temperature / RT			
Light Height / 14 cm			

SciTrek Member Approval: _____

QUESTION

Question our subgroup will investigate:

- If we change the shading amount _____, what will happen to the power produced by the solar panel _____?

#4 EXPERIMENTAL SET-UP: SPECIFIC

(Once filled out, staple to notebook pg. 21)

If you are responsible for presenting your team's specific experimental set up, fill in the following sentence frame with information from your Experimental Set-Up. This is what you will read when you present.

Our team's subgroup control is panel angle. The values our team used are 30°, and 75°. We picked these values because we wanted our trend lines to be spread out so we spread our shading amounts across the range.

out our changing variable values so our data points will also be spread out.

Controls (variables you will hold constant):
Write your controls and the values you will use in all your trials (control value, Ex: power source/solar panel).

Class and Team Controls (same values between subgroups)		Subgroup Control (different values between subgroups)	
Power Source / Solar Panel	Panel Angle / 30°		
Temperature / RT			
Light Height / 14 cm			

SciTrek Member Approval: SL

Ex: Highlighted and Numbered Notebook Pages

Sticker

#5a RESULTS

We are subgroup 0. Our changing variable is shading amount and the values we used are 0/8, 10%, 4/8, 50%, 6/8, 75%, and 8/8, 100%.

Subgroup Control: Panel Angle Shading Amount Temperature Subgroup Symbol: 0

Variables	Trial D	Trial E	Trial F	Trial G
Power Source: Solar panel				
Panel Angle: <u>30°</u>				
Changing Amount: <u>0/8</u>	<u>4/8</u>	<u>6/8</u>	<u>8/8</u>	
Temperature: <u>Room Temp: 22°C</u>	<u>RT</u>			
Light Height: <u>14 cm</u>				

***5b is not shown. It is identical to 5a but given to a student in the other subgroup.**

Current (mA)	Power (mW)	5.4 mA x 2.1 V =	2.9 mA x 1.5 V =	1.7 mA x 1.9 V =	0.1 mA x 0.6 V =
	$P = I \times V$	<u>11.3 mW</u>	<u>5.5 mW</u>	<u>3.2 mW</u>	<u>0.1 mW</u>

The independent variable is the changing variable and the dependent variables are the current and voltage.

#6 PROCEDURE

Procedure Note: Make sure to include all values of your changing variable(s) in the procedure. Ex: For a subgroup that decided to change panel angle one step would be: Place the panel at an angle of 0°, 10°, 45°, 75°, and 90°.

Set up lamp using the spacing tool 14 cm above

- Place shading tool on solar panel at appropriate shading amount.
- Place the panel at the appropriate angle.
- Position panel directly under lamp, and turn lamp on.
- Do not heat the solar panel, leave at RT.
- Use multimeter to measure the current (mA) and voltage (V).
- Calculate the power by multiplying current and voltage.

SciTrek Member Approval: SL

#7: GRAPH: GENERAL

(Once filled out, staple to notebook pg. 24)

If you are responsible for presenting your team's graph, fill in the following sentence frame. This is what you will read when you present.

All of our graphs showed a decreasing trend.

We think subgroup 0 had the most convincing data because the data points were closest to the trend line.

Legend:
 Subgroup Control
 Panel Angle
 Shading Amount
 Temperature
 Subgroup Symbol: 0
 30°
 75°

#8 RESULTS Graph

Modified Name of Changing Variable: Panel Angle: Percent Angled
 Panel Angle: Percent Angled
 Shading Amount: Percent Shaded
 Temperature: Percent Heated

Set up your graph. (Check off the steps as you complete them.)
 Write the title for your graph by filling in the blanks.
 Label the y-axis (vertical) with what you calculated, including units (Ex: Power (mW)).
 Label the x-axis (horizontal) with your modified name of changing variable, including units (Ex: Percent Angled (%)).
 Select your subgroup control in the legend by checking the appropriate box. Then, put your subgroup control symbol next to your subgroup symbol.
 On the x-axis, circle your 4 changing variable values (as percentages). If a value is not there, write it in.
 Starting with the smallest changing variable value, determine the power, and put your subgroup symbol at the appropriate level. Write the power next to the point.
 Once you have plotted all 4 points, draw a trend line that best fits your data.

Plot the 0 group specific data.
 When the solar panel was 0 shaded, the power was 11.3 mW.

Effects of Shading amount and panel angle on the power

Legend:
 Subgroup Control
 Panel Angle
 Shading Amount
 Temperature
 Subgroup Symbol: 0
 30°
 75°

#9 CONCLUSION

We can conclude when the solar panel is less shaded, more power will be produced.

because when the solar panel was 0/8 shaded (0%), 11.3 mW of power was produced, and when the panel was 8/8 shaded (100%), 0.1 mW of power was produced.

I acted like a scientist when I graphed my results.

TEAM PREDICTIONS

Use your team graph to predict the power for each subgroup if you were to use 5% of your changing variable. Write your predictions in the table below.

Percent Changing Variables: 5%	
Subgroup Symbol	Prediction
<u>0</u>	<u>3.8 mW</u>
<u>Δ</u>	<u>1.5 mW</u>

SciTrek Lead:

- Notebooks should have been highlighted, stickered, and numbered at UCSB. Confirm this has taken place. If not, use the poster diagram page to have mentors do this quickly before starting SciTrek.
- Make sure mentors are setting out notebooks.
- Set up the document camera for the *Notes on Presentations* (picture packet, page 7).

SciTrek Mentors:

- Set out notebooks/nametags.

Note: Set notebooks where students will sit during the module, even if another student is currently at that desk. If needed, students will move to these spots after the Introduction.

Picture Packet Page and Notebook Page:

NOTES ON PRESENTATIONS
What variables affect the power produce by a solar panel?

Percent Changing Variable:	<input type="checkbox"/> Panel Angle <input checked="" type="checkbox"/> Shading Amount <input type="checkbox"/> Temperature	0%	50%	75%	100%
Power (mW):		11.3	5.5	3.2	0.1

Summary: As shading amount decreases, power increases.
Also, panel angle was a subgroup control and the smallest angle was the highest line on the graph.

Percent Changing Variable:	<input checked="" type="checkbox"/> Panel Angle <input type="checkbox"/> Shading Amount <input type="checkbox"/> Temperature	0%	25%	63%	88%
Power (mW):		11.8	9.2	5.4	1.3

Summary: As the panel is less angled, more power is produced.
Also, temperature was a subgroup control and both trend lines were on top of each other.

Percent Changing Variable:	<input type="checkbox"/> Panel Angle <input type="checkbox"/> Shading Amount <input checked="" type="checkbox"/> Temperature	12%	44%	76%	100%
Power (mW):		8.0	7.8	8.1	7.5

Summary: Temperature does not affect the amount of power produced by the solar panel.
Also, shading was a subgroup control and the least shaded panel line was the highest on the graph.

7

Picture Packet, Page 7

NOTES ON PRESENTATIONS
What variables affect the power produced by a solar panel?

Percent Changing Variable:	<input checked="" type="checkbox"/> Panel Angle <input type="checkbox"/> Shading Amount <input type="checkbox"/> Temperature	0%	25%	63%	88%
Power (mW):		11.8	9.2	5.4	1.3

Question: Why do all of your group's trend lines look like they are on top of each other?

Summary: As the panel is less angled, more power is produced.
Also, temperature was a subgroup control and both trend lines were on top of each other.

Percent Changing Variable:	<input type="checkbox"/> Panel Angle <input type="checkbox"/> Shading Amount <input checked="" type="checkbox"/> Temperature	12%	44%	76%	100%
Power (mW):		8.0	7.8	8.1	7.5

Question: If the temperature was 100°C, how much power do you think the solar panel would produce?

Summary: Temperature does not affect the amount of power produced by a solar panel.
Also, shading was a subgroup control and the least shaded panel line was the highest on the graph.

26

Introduction:

(2 minutes – Full Class – SciTrek Lead)

If students are not in their subgroups, tell them, “A notebook will be put on your desk, which is not your notebook and you should not move it. You will move to your notebook after the Introduction.”

Ask the class, “What is the class question we have been investigating?” Students should reply, “What variables affect the power produced by a solar panel?” Tell students, “When scientists complete their experiments, they make posters to present their findings to other scientists. Each team will create a poster to present to the class. This presentation will be your chance to tell the class what your team has discovered about the class question. You should write as neatly as possible on the poster parts so that the other class members can read your posters. You will have 25 minutes to make the posters, and then 5 minutes to practice presenting them with your teams. When you present, you will read from your notebooks.”

Poster Making:

(25 minutes – Subgroups – SciTrek Mentors)

Each team (6-11 students) will make one poster about their second experiment, so there will be three presentations total. Every student on the team will have both a writing and a speaking part in the presentation.

The notebooks will already be highlighted with what part each student will fill out and the corresponding poster part will be paper clipped to their notebooks. Note: Part 4 and 7 do not have poster parts to fill out. They will just fill out the white paper stapled in their notebook. Below are specific notes for the student doing each of the noted sections.

Part 5 (Results Table): Make sure these students completely fill in the stickers in their notebooks (shown below) as well as the results table poster piece.

We are subgroup _____. Our changing variable is _____, and the values we used are _____/_____, _____/_____, _____/_____, and _____/_____.

Part 6 (Procedure): Make sure when the student copies the procedure onto the poster part, they copy the modified steps that have been stapled into their notebook.

Part 7 (Graph General): Tell this student which subgroup's data (the subgroup of the person that is presenting the conclusion) was selected as the best data and have them think about why. Then have them record this on the white sheet stapled in their notebook.

Part 8 (Graph Specific): The following sentence frame sticker will be put in their notebook.

When the solar panel was _____% _____ the power was _____ mW.

(fill out this blank for the student)

percentage changing variable power

One of the blanks in the sentence frame will be filled out, do not fill in anymore of blanks. Students will fill in their blanks orally as they present. An example of a first sentence might be: When the solar panel was **0%** shaded the power was **11.3** mW. Where the student got the 0% and 11.3 from their graph. Practice reading the four sentences with the student.

Once students have finished their section(s), have students add to the *ways we acted like scientists* poster part. To do this, they can copy their *I acted like a scientist when* statements from page 25 of their notebooks, or come up with new ones.

As soon as students have completed some of their pieces, start gluing them onto the large poster paper, in landscape orientation, exactly as they are arranged in the example below. Do not allow students to glue the poster parts on the posters. Do not wait until students have completed all the pieces to start gluing them onto the posters.

Once the poster is complete, have students start practicing for the presentation. Make sure students read from their notebooks, instead of from the poster.

The poster diagram is a 2x3 grid of student work samples. Each sample is a rectangular card with a title and content. The top row contains: a question card (Student 1), a data table (Student 2), and a graph (Student 3). The bottom row contains: a procedure card (Student 4), another data table (Student 5), and another graph (Student 6). A central label 'Poster Diagram' is at the bottom.

Student 1 Question Card:
 question
 If we change the shading amount, what will happen to the amount of power produced by the solar panel?

Student 2 Data Table:
 RESULTS

Shading (%)	Volt	mA	Power (mW)
0%	1.8 V	6.3 mA	11.34
25%	1.5 V	5.2 mA	7.80
50%	1.2 V	4.1 mA	4.92
75%	0.9 V	3.0 mA	2.70
100%	0.6 V	2.0 mA	1.20

Student 3 Graph:
 Effects of Shading Amount and Power Produced by the Panel
 Graph showing Power (mW) vs. Percent Shaded (%). The curve shows a downward trend.

Student 4 Procedure Card:
 PROCEDURE
 1. Set up the circuit as shown.
 2. Measure the voltage across the solar panel at appropriate shading amounts.
 3. Measure the current through the solar panel at the same shading amounts.
 4. Calculate the power produced by the solar panel at each shading amount.
 5. Record the data in the table.

Student 5 Data Table:
 RESULTS

Shading (%)	Volt	mA	Power (mW)
0%	1.8 V	6.3 mA	11.34
25%	1.5 V	5.2 mA	7.80
50%	1.2 V	4.1 mA	4.92
75%	0.9 V	3.0 mA	2.70
100%	0.6 V	2.0 mA	1.20

Student 6 Graph:
 We can conclude that when the solar panel is less shaded, more power will be produced. Because when the solar panel is 0% shaded, it is a max of power was produced, and when the panel was 100% shaded, it was 0.1 mW of power was produced.

Practice Posters:

(5 minutes – Subgroups – SciTrek Mentors)

While mentors are practicing their poster presentations with their teams, the lead should organize posters, so they are presented from simplest to understand, to most difficult to understand (suggested order: shading amount, panel angle, and temperature).

Have your team practice their poster presentation, making sure they are reading the poster parts in the correct order (scientists' names, question, experimental set-up: general, experimental set-up: specific, results table \circ , results table Δ , procedure, results graph: general, results graph: specific, and conclusion). Make sure each student's part is highlighted in their notebook. If students are reading from multiple pages, use a paperclip to clip these pages together, to make it easier for them to flip back and forth. Remind students to read from their notebooks, rather than from their posters.

Do not let poster practice go over 5 minutes.

Poster Presentations:

(31 minutes – Full Class – SciTrek Mentors/SciTrek Lead)

Have students return to their original class seats. Ask the class, "What is the question we have been investigating?" Students should reply, "What variables affect the power produced by a solar panel?" Tell students, "During the presentations, you are going to take notes." Have them turn to page 26 in their notebooks, while you turn to page 7 of the picture packet. Tell them, "You will need to check the box for each team's changing variable after the team says their question. In addition, when the group presents their graph (specific), you will need to record the values of the changing variable as percentages, as well as the corresponding powers."

Tell students, "Everyone will need to generate at least one scientific question per presentation, and write it in their notebook. If you think of a question during the presentation, you can write it down then, or, you will be given 1 minute at the end of the presentation to write down your question. These questions should focus on helping you be able to understand or summarize the team's findings. After we have all written questions, you will be given time to ask them to the presenting group. These questions are important, because after asking questions, you will have to record a summary of what you learned from the team. In addition, if you ask a question during the presentations, you will receive a SciTrek pencil at the end of the session."

Explain to students, "One very important thing to an engineer is the ability to build something that works, as well as being cost efficient. When comparing different percentages of changing variable values, you should keep in mind the possible cost. If an expensive option would produce significantly higher power, it might be worth it to spend the extra money to build it; however, if the more expensive option would produce the same power as a cheaper option, it would be best to build the cheaper option. Therefore, before moving on to the next presentation, as a class we will decide which value of the changing variable would be the 'best' for a solar power company to use." Both you and the students will circle the "best" percent changing variable value in the presentation notes.

In addition to stopping the presentation after the question, also stop it after the team has presented their Experimental Set-Up: Specific and have the class identify the team's subgroup control. Then, record this above the data table on the *Notes on Presentations*, students do not need to record this if they do not want to. After the first presentation, stop the presentation after the team has read their procedure and have the class predict what trend they think the team saw both within their trend lines and between trend lines. Below is a list of what students should learn from each presentation along with the predictions they should be able to make.

Presentation 1 (Changing Variable: Shading Amount, Subgroup Control: Panel Angle)

What students should be able to predict:

For this presentation they will not be able to predict anything

What students should have learned from the presentation:

The less shading the higher the power

The less angle the higher the power

Presentation 2 (Changing Variable: Panel Angel, Subgroup Control: Temperature)

What students should be able to predict:

There should be a decreasing trend for panel angel (students learned this from the subgroup control of presentation 1)

What students should have learned from the presentation:

The less angled the higher the power (confirmed what team 1 saw)

The temperature does not affect power

Presentation 3 (Changing Variable: Temperature, Subgroup Control: Shading Amount)

What students should be able to predict:

There should be no trend (flat line) for temperature (students learned this from the subgroup control of presentation 2)

The subgroup's line with a small shading amount should be higher on the graph (student learned this from the changing variable of presentation 1)

What students should have learned from the presentation:

The temperature does not affect the power (confirmed what team 2 saw)

The less shading the higher the power (confirmed what team 1 saw)

Notebooks only have room for notes and questions on two presentations. Therefore, students will not take notes on their own presentation.

Mentors should make sure students are quiet and respectful when other teams are presenting. When your team is presenting, go to the front of the room with them; prompt students if they do not know who talks next and remind them to read from their notebooks.

After each team has given their presentation, take one of their notebooks and put the graph under the document camera, so that it may be seen during student question time. During this time, the lead and/or mentors should ask at least one question. Examples of possible questions are: "How do you know...?" or "Is there anything else you can do to get more information about your question?" Each team should answer approximately 10 questions (one question per student). When students are done asking questions, have them summarize what the team found and circle the percentage of the changing variable that would be "best" for a solar power company. In your summary make sure to include what the team learned about both their changing variable and their subgroup control.

An example filled out *Notes on Presentations* (left) and student notes (right) are shown below.

NOTES ON PRESENTATIONS
What variables affect the power produced by a solar panel?

Subgroup Control: Panel Angle

Percent Changing Variable:	<input type="checkbox"/> Panel Angle <input checked="" type="checkbox"/> Shading Amount <input type="checkbox"/> Temperature	0%	50%	75%	100%
Power (mW):		11.3	5.5	3.2	0.1

Summary: As shading amount decreases, power increases.
Also, panel angle was a subgroup control and the smallest angle was the highest line on the graph.

Subgroup Control: Temperature

Percent Changing Variable:	<input checked="" type="checkbox"/> Panel Angle <input type="checkbox"/> Shading Amount <input type="checkbox"/> Temperature	0%	25%	63%	88%
Power (mW):		11.8	9.2	5.4	1.3

Summary: As the panel is less angled, more power is produced. Also, temperature was a subgroup control and both trend lines were on top of each other.

Subgroup Control: Shading Amount

Percent Changing Variable:	<input type="checkbox"/> Panel Angle <input type="checkbox"/> Shading Amount <input checked="" type="checkbox"/> Temperature	12%	44%	76%	100%
Power (mW):		8.0	7.8	8.1	7.5

Summary: Temperature does not affect the amount of power produced by the solar panel. Also, shading was a subgroup control and the least shaded panel line was the highest on the graph.

Picture Packet, Page 7

NOTES ON PRESENTATIONS
What variables affect the power produced by a solar panel?

Percent Changing Variable:	<input checked="" type="checkbox"/> Panel Angle <input type="checkbox"/> Shading Amount <input type="checkbox"/> Temperature	0%	25%	63%	88%
Power (mW):		11.8	9.2	5.4	1.3

Question: Why do all of your group's trend lines look like they are on top of each other?

Summary: As the panel is less angled, more power is produced. Also, temperature was a subgroup control and both trend lines were on top of each other.

Percent Changing Variable:	<input type="checkbox"/> Panel Angle <input type="checkbox"/> Shading Amount <input checked="" type="checkbox"/> Temperature	12%	44%	76%	100%
Power (mW):		8.0	7.8	8.1	7.5

Question: If the temperature was 100°C, how much power do you think the solar panel would produce?

Summary: Temperature does not affect the amount of power produced by a solar panel. Also, shading was a subgroup control and the least shaded panel line was the highest on the graph.

After all poster presentations have been given, ask the class, “What did we learn about the power produced by a solar panel?” Have them summarize the class findings. The highlights from the experiments are shown below.

- As the *shading amount* decreases, the power increases.
- As the *panel angle* gets closer to 30°/0%, the power increases.
- The *temperature* does not affect the power.

Note: Timing is tight on this day. It is possible that students will only get through two of the three presentations during the allotted time. In this case, the teacher will need to lead the third poster presentation, outside of SciTrek time, before the next session.

Wrap-Up:

(2 minutes – Full Class – SciTrek Lead)

Tell students, “The mentors who have been working with you are undergraduate and graduate students who mentor their time so you can do experiments. This is the last day you will see your mentors, so we should say thank you and goodbye to them. I will come back and work with you one more day.”

Have students remove the paper parts of their nametags (which they can keep) from the plastic holders, and return the plastic holders to their mentors.

Have mentors pass out pencils to students who asked questions. If a student did not ask a question during the poster presentations, have them ask/answer a question about the experiments before the mentor gives them a pencil.

Clean-Up:

1. Collect plastic nametag holders and allow students to keep the paper part of their nametag.
2. Collect notebooks.
3. Leave posters in the classroom.
4. Place all other materials into your group box and bring them back to UCSB.
5. If you will not be attending the tie to standards day, remove all items from your lab coat pockets, remove your nametag, unroll your lab coat sleeves, and put your lab coat into the dirty clothes bag at UCSB.

Day 8: Analysis Assessment/Tie to Standards**Schedule:**

Analysis Assessment (SciTrek Lead) – 10 minutes

Tie to Standards (SciTrek Lead) – 50 minutes

Materials:**Lead Box:**

- | | | |
|---|--|--|
| <input type="checkbox"/> (3) Extra notebooks | <input type="checkbox"/> Lead lab coat | <input type="checkbox"/> (2) Pencils |
| <input type="checkbox"/> Notebooks | <input type="checkbox"/> (35) Analysis Assessments | <input type="checkbox"/> (2) Wet erase markers |
| <input type="checkbox"/> Lead instructions | <input type="checkbox"/> Time card | <input type="checkbox"/> (35) Clear rulers |
| <input type="checkbox"/> Solar Power picture packet | | |

Other Supplies:

- | | |
|---|--|
| <input type="checkbox"/> Bag with lamp, extension cord, and power strip | <input type="checkbox"/> Box of tie to standards materials (LED bulb, CFL bulb, Halogen bulb, hanging lightbulb holder, green and white LED cups, amp meter, multimeter with leads, multimeter with probe leads, black cloth, protractor, solar panel, solar panel holder, spacing tool shading tool, (2) binder clips (15 mm), (2) long wires with alligator clips) |
| <input type="checkbox"/> Calculator box | |

Notebook Pages and Picture Packet Pages:

TIE TO STANDARDS

1. What is power? A measure of energy over time.

Predicting Power

We know that different colored LEDs will turn on at different powers. The power required to turn on a green and white LED is given below.

Green LED: 3.6 mW White LED: 64.6 mW

2. Annotate the graph below, draw trend lines, label subgroup controls, and answer the questions.

Engineer Symbol	Shading Amount	Temperature
○	$\frac{0}{8}$	RT
△	$\frac{4}{8}$	RT
X	$\frac{6}{8}$	RT

Does this graph show a trend that is consistent with the class findings?
 YES NO

3. Using data from the graph, what power would you expect to calculate if you used a solar panel that was $\frac{5}{8}$ shaded, 40° angled (50°), and at room temperature?

Which experiment(s) should you look at?
 ○ △ X Prediction: 5.5 mW

Actual:
(Round to the nearest tenth)

Current: 2.6 mA
 Voltage: 1.9 V
 Power: 4.9 mW

4. Would this be enough power to light the green LED? YES NO

5. Would this be enough power to light the white LED? YES NO

Power Sources/Uses

6. What is power consumption? The power you use in some time.

7. What would we need to do if we wanted to monitor the power consumption in this classroom? Measure the current and voltage of devices in the room over some time period.

8. Why is it useful for us to be able to monitor the power consumption?
To know how much power we are using.

9. What is the main way we monitor our monthly power consumption?
Through our power bill.

In California, we are able to produce power from different energy sources. Some are renewable and some are non-renewable.

10. Match the definitions:

1. Renewable Energy Source

2. Non-renewable Energy Source

a. A source that is not replenished as fast as it is consumed (i.e. cannot be replenished within a human's lifetime).

b. A source that produces energy that is not used up or can be replenished within a human's lifetime.

Renewable Energy Sources	Non-renewable Energy Sources
<u>Solar</u>	<u>Coal</u>
<u>Wind</u>	<u>Gasoline</u>
<u>Biofuel</u>	<u>Natural Gas</u>

Effects of Power Use

In the table above, circle all energy sources that are burned to obtain energy.

11. When energy sources are burned, carbon dioxide (CO₂) is produced.

Scientists have found a link between carbon dioxide (CO₂) levels and temperature. Using the graphs below, determine how the two are related.

12. As CO₂ levels increase, atmospheric temperature increases, because in 2000, there were 375 ppm of CO₂ in the atmosphere and the temperature was 0.5°C above average, and in 1900, there were 290 ppm of CO₂ in the atmosphere and the temperature was 0.1°C below average.

13. If California uses non-renewable energy sources for power, what will happen to the amount of CO₂ in the atmosphere? It will increase.

14. What will this mean about average atmospheric temperatures? They will increase.

15. In California, 47% of our electrical energy comes from renewable sources.

Bright Choices

16. How can we minimize our impact on our CO₂ production?
Reduce electricity use and efficiently use electrical devices.
 We will look at 3 different types of lightbulbs:

1. LEDs 2. compact fluorescent (CFL) 3. incandescent/halogen

17. Lumens: How much light a lightbulb gives off.
 Is this important to hold constant when comparing lightbulbs? YES NO
(Circle one)

18. Temperature: What color of light a lightbulb gives off.
 Is this important to hold constant when comparing lightbulbs? YES NO
(Circle one)

Will lightbulbs with the same number of lumens need different amounts of power to light?

Type of lightbulb:	LED	CFL	Incandescent/Halogen
Voltage:	120 V	78 V	120 V
Current:	0.064 A	0.115 A	0.326 A
Power:	7.7 W	9.0 W	39.1 W

19. Which bulb is "best?" The LED, it uses less power to work.

The box for each of the lightbulbs is shown below. Compare the information on the boxes and answer the questions below.

Lighting Facts
Per Bulb

Brightness 550 lumens

Estimated Yearly Energy Cost \$0.84
Based on 3 hrs/day, 11¢/kWh. Cost depends on rates and use

Life 10 years
Based on 3 hrs/day

Light Appearance
Warm Cool
5000 K

Energy Used 7 watts

LED

Lighting Facts
Per Bulb

Brightness 550 lumens

Estimated Yearly Energy Cost \$1.00
Based on 3 hrs/day, 11¢/kWh. Cost depends on rates and use

Life 9.1 years
Based on 3 hrs/day

Light Appearance
Warm Cool
5000 K

Energy Used 9 watts

Contains Mercury
For more on clean up and safe disposal, visit epa.gov/cfl.

CFL

Lighting Facts
Per Bulb

Brightness 550 lumens

Estimated Yearly Energy Cost \$4.82
Based on 3 hrs/day, 11¢/kWh. Cost depends on rates and use

Life 2.3 years
Based on 3 hrs/day

Light Appearance
Warm Cool
2000 K

Energy Used 40 watts

Incandescent/Halogen

20. What does the life of the lightbulb tell us? How long the bulb will last.

21. What does the estimated yearly energy cost of the lightbulb tell us?
How much it costs to run the lightbulb.

22. The LED lightbulb is best because it uses the least power to work (7.7 W), it lasts the longest (10 years), and it costs the least amount of money to run (\$0.84).

Preparation:

SciTrek Lead:

1. If the teacher is not leading the tie to standards activity, do the following:
 - a. Give the teacher an extra notebook and have them fill it out with their students, to follow along during the tie to standards activity.
 - b. Collect the teacher's lab coat and put it in the lead box.
2. Pass out the analysis assessments and notebooks.
3. Set up the document camera for the tie to standards activity (notebook, pages 27-30).
4. Assemble the tie to standards set-ups accordingly:
 - a. Plug an extension cord into the wall and a power strip into the extension cord. We do not want to accidentally blow a circuit breaker during the *Bright Choices* section of the tie to standards activity, therefore, we must set this up accordingly.
 - b. Set up the Solar Panel Set-Up.
 - i. Use the shading tool to shade $\frac{2}{8}$ of the panel.
 - ii. Place a solar panel in the solar panel holder and turn the angle to 50°.
 - iii. Hook the multimeter up to the panel.
 - iv. Plug the lamp into the power strip.
 - v. Place the entire set-up near the document camera.
 - c. Set up the *Bright Choices* Set-Up.
 - i. Screw the LED bulb into the hanging lightbulb holder and set it in the tie to standards materials box.
 - ii. Have compact florescent and halogen bulbs nearby.
5. Put your lab coat in the lead box at the end of the day.

Analysis Assessment:

(10 minutes – Full Class – SciTrek Lead)

Tell students, "Before we start our activity today, we will determine how your ideas on analyzing and interpreting data are developing." Have students write their name, teacher's name, and date at the top of the assessment. Tell students, "When doing this assessment, you should work individually, so there should be no talking." As you are giving the assessment, walk around the room and verify students have written their names on their assessments.

For page 1, read the directions for annotating to the students. Then, have students annotate the first results table by underlining controls, circling changing variables, and boxing information about data collection. Read question 1b (*Can this group make a conclusion?*) and have students answer the question. Have students annotate the possible conclusion. Finally, read question 1d (*Is this a correct conclusion for the results table? If NO, what is wrong with the conclusion?*), and have students answer the question. Repeat this process for questions 2 and 3.

Pass out rulers to students. Read the directions for question 4 to students. Then, have students annotate the graph by underlining controls, circling changing variables, and boxing information about data collection. Have students plot the remaining points on the graph using circles as markers. Then, tell students, "Draw trend lines for each experiment on the graph." Read questions 4d-4f and give students time to answer each. When they are finished, collect the assessments and verify the students' names are on the top. Students should keep their rulers to use during the tie to standards activity.

Tie to Standards:

(50 minutes – Full Class – SciTrek Lead)

Have students open their notebook to page 27 while you open the class notebook to page 27 and place it under the document camera. Tell students, “I enjoyed hearing about your experiments last session, you were talking a lot about power during the presentations.” Ask students, “What is power?” Lead students to understand that power is energy over time and record this for question 1 while students do the same. Ask students, “Why do we care about the power a solar panel can produce?” If students are struggling with the answer tell them to think back to the LEDs on Day 1 of the module. Possible student response: devices operate at different amounts of power, and if we can figure out how to position a solar panel to produce a certain amount of power, we can use that solar panel to power a device.

Predicting Power (15 minutes)

Pass out a calculator to each student.

Tell students, “On the first day of this module we observed how much power it took to light a blue and red LED. Today we will look at a white and a green LED.” Direct students’ attention to the turn-on power for each LED at the top of page 27. Tell students, “In order to light a white LED, 64.6 mW of power are needed, and in order to light a green LED, 3.6 mW of power are needed. We will use the graph in question 2 to determine if it will be possible to light each LED using a solar panel at the given specifications.” Read the directions for question 2. Have students annotate the graph, and draw and label trend lines on their own. While they are doing this take the class notebook out from under the document camera and do the same. After ~2 minutes put the class notebook under the document camera so students can check their answers.

Once students have finished, ask them, “What was this team’s changing variable?” Students should reply, “Panel angle.” Then, ask students, “What was this team’s subgroup control?” Students should reply, “Shading amount.” Lastly, ask students, “What was this team’s team control?” Students should reply, “Temperature.” Ask students, “What did we learn about temperature from our class experiments?” Possible student response: temperature does not affect the power produced by a solar panel. Ask students, “If this team decided to run their experiments at 35°C instead of room temperature, how would that affect their results?” Possible student response: it should not affect their results since temperature does not affect the power produced by a solar panel. Tell students, “Therefore, we can cross off temperature in the controls because we will not have to worry about that.” Put an x over the temperature values in the controls while students do the same.

Ask students, “What did we learn about panel angle from our experiments?” Possible student response: as the panel is less angled, the power increases. Ask students, “What did we learn about shading amount from our experiments?” Possible student response: as the panel is less shaded, the power increases. Ask students, “Does this graph show a trend that is consistent with our class findings?” Students should reply, “Yes,” and circle this response to the question under the Graph 1 Controls box.

Read question 3 to the students (*Using data from the graph, what power would you expect to calculate if you used a solar panel that was $\frac{2}{8}$ shaded, 40% angled (50°), and at room temperature?*). Ask students, “If we want to answer this question, which experiment/experiments do we need to look at and how do you know?” Possible student response: the circle and triangle experiments because $\frac{2}{8}$ shading falls directly between $\frac{0}{8}$ and $\frac{4}{8}$ shading. Circle these symbols in question 3. Ask students, “How do we find the power?” Possible student response: we should draw an estimated trend line halfway between $\frac{0}{8}$ and $\frac{4}{8}$, and then use that trend line to determine the power. Have students draw their trend line and determine the predicted power on their own while you do the same in the class notebook. Tell students, “Once you have

finished, check your answer with mine.” To determine the power prediction, place your ruler vertically at the 40% mark and draw a dashed line up to your dashed trend line. Then, place your ruler horizontally at the intersection of your two dashed lines and draw another dashed line back to the y-axis. The point at which you hit the y-axis will be the predicted power. You should get 5.5 mW. Remind students that their prediction should be within 0.3 mW of the prediction written in the class notebook.

Tell students, “We will now test our predictions.” Place the multimeter under the document camera and tell students, “I have already set up a solar panel at $\frac{2}{8}$ shaded, 40% angled [50°], and room temperature, but to ensure no outside light will affect the results, we will put this black cloth over the set-up.” Turn on the lamp and place the black cloth over the lamp and solar panel set-up (the multimeter should be left outside of the cloth, and able to be placed under the document camera). Place the multimeter under the document camera and turn the multimeter dial to the setting boxed in black and have the students read and record the current produced by the solar panel. Turn the multimeter dial to the setting boxed in silver and have students read and record the voltage produced by the solar panel. Ask students, “How do we calculate power?” Students should reply, “We multiply the current and voltage together.” Have students use calculators to calculate the power while you do the same under the document camera. Have students check their answer with yours.

Remove the multimeter from under the document camera and turn off the lamp. Next, ask students, “Will this be enough power to light the green LED, and how do you know?” Possible student response: yes, the green LED only requires 3.6 mW of power to turn on. If they are having trouble, direct their attention to the top of page 27 where the turn-on power for each of the LEDs is located. Once the class has agreed that this will be enough power to light the green LED, circle “Yes” for question 4. Then, ask students, “Will this be enough power to light the white LED, and how do you know?” Possible student response: No, the white LED requires 64.6 mW of power to light. Once the class has agreed, circle “No” for question 5.

Tell students, “Next we will test these predictions.” Unhook the multimeter from the solar panel and attach the green LED cup via the alligator clips (remember, the red foot of the LED is clipped to the red lead, and the black foot of the LED is clipped to the black lead). Make sure the black cloth is over the entire set-up, except the LED cup, and turn on the lamp. The green LED should light. Shine the light around the room so every student can see the LED lit up. If they are having trouble telling the LED is lit, place your hand over the solar panel to block the light (the LED should unlight) and remove your hand (the LED should light). Unhook the green LED and attach the white LED in the same manor to the solar panel. The white LED should not light. Again, make sure that each student sees the unlit LED. Unhook the LED and set it aside. An example page 27 is shown below

TIE TO STANDARDS

1. What is **power**? A measure of energy over time.

Predicting Power

We know that different colored LEDs will turn on at different powers. The power required to turn on a green and white LED is given below.

Green LED: 3.6 mW White LED: 64.6 mW

2. Annotate the graph below, draw trend lines, label subgroup controls, and answer the questions.

Controls		
Engineer Symbol	Shading Amount	Temperature
○	$\frac{0}{8}$	RT
△	$\frac{4}{8}$	RT
X	$\frac{6}{8}$	RT

Does this graph show a trend that is consistent with the class findings?
 YES NO

3. Using data from the graph, what power would you expect to calculate if you used a solar panel that was $\frac{2}{8}$ shaded, 40% angled (50°), and at room temperature?

Which experiment(s) should you look at?
 ○ △ X Prediction: 5.5 mW

Actual:
(Round to the nearest tenth)

Current: 2.6 mA
 Voltage: 1.9 V
 Power: 4.9 mW

4. Would this be enough power to light the **green** LED? YES NO

5. Would this be enough power to light the **white** LED? YES NO

27

Power Sources/Uses (5 minutes)

Tell students, “Now we understand how to predict power, let’s think about how we use power, as well as where our power comes from.” Have students turn to page 28 in their notebooks while you do the same in the class notebook under the document camera. Ask students, “What is power consumption?” Have the students generate some ideas and lead them to the idea that power consumption is the amount of power we use in a given time. Record this for question 6. Ask students, “What would we need to do if we wanted to monitor the power consumption in this classroom?” Possible student response: measure the current and voltage of devices in the room. Record this for question 7. Ask students, “Why is it useful for us to be able to monitor the power consumption?” Possible student response: that way we can know how much power we are using. Record this for question 8. Lastly, ask students, “What is the main way we monitor our monthly power consumption?” Possible student response: through our power bill. Record this for question 9. If students are struggling, explain to them that every month, a local power company (Ex: In Santa Barbara, Southern California Edison) monitors our energy/power usage to determine how much we are consuming. They then send us a bill that tell us how much energy we used, and how much that energy costs.

Power Sources/Uses

6. What is **power consumption**? The power you use in some time.

7. What would we need to do if we wanted to monitor the power consumption in this classroom? Measure the current and voltage of devices in the room over some time period.

8. Why is it useful for us to be able to monitor the power consumption?
To know how much power we are using.

9. What is the main way we monitor our monthly power consumption?
Through our power bill.

Tell students, “In California, we are able to produce power from different energy sources. Some are renewable and some are non-renewable.” Read question 10 to students (*Match the definitions: renewable energy source, non-renewable energy source*). Have students read the definitions to

themselves, and raise their hand when they think they've found the match for each definition. Call on a student to share their answer and see if the class agrees. Once you've reached a consensus, draw lines connecting the correct phrase to the correct definition.

10. Match the definitions:

1. Renewable Energy Source	a. A source that is not replenished as fast as it is consumed (i.e. cannot be replenished within a human's lifetime).
2. Non-renewable Energy Source	b. A source that produces energy that is not used up or can be replenished within a human's lifetime.

Ask students, "What are some renewable or non-renewable energy sources that you know of?" List the student responses in the table under question 10. Possible student responses can be seen in the picture below. Only write down the sources students generate. They might not suggest all of the ones listed in this example.

Renewable Energy Sources	Non-renewable Energy Sources
<u>Solar</u>	<u>Coal</u>
<u>Wind</u>	<u>Gasoline</u>
<u>Biofuel</u>	<u>Natural Gas</u>

Note: The three main fossil fuels (fuels formed in the geological past from the remains of living organisms) are coal, oil, and natural gas. If oil is suggested as a non-renewable energy source, lead students to understand that the main use of oil is in gasoline and write down *gasoline* instead of *oil* in the table. Crude oil is used for other things such as kerosene, asphalt, and plastics but students do not have as close of connections to these as gasoline. In addition, it is easiest for students to understand that gasoline must be burned to release its energy.

Note: If students bring up nuclear energy, it should be put under a non-renewable energy source because there is a limited amount of uranium-235 on Earth.

Take down the Solar Panel Set-Up and replace it with the Bright Choices Set-Up. Make sure to replace the alligator clips in the multimeter with the probes, and that the LED bulb is screwed into the free-hanging lightbulb holder. Place the multimeter, LED bulb in free hanging holder, CFL bulb, halogen bulb, and amp meter, next to the document camera set-up.

Effects of Power Use (15 minutes)

Tell students, "Now that we understand where our power comes from, let's think about how our power consumption affects the world around us. Remember, power is the measure of energy over time. What form of energy is our solar panel producing?" Students should reply, "Electrical energy." Ask students, "In order to obtain electrical energy from our solar panel, what did we have to provide?" Possible student response: we had to turn on a lamp. Tell students, "This means that the energy from light can be harnessed by a tool like a solar panel, in order to convert the energy in light into electrical energy for us to use." Ask students, "If we wanted to obtain electrical energy from wind, another one of our renewable energy sources, what tool would we have to use?" Students should reply, "A wind turbine."

Tell students, "To transfer the energy into a form that is useful to us, some energy sources have to be burned." Have students tell you which energy sources are burned in the table and circle them in the class notebook while students circle them in their notebook. All the energy sources in the non-renewable category should be circled (with the exception of nuclear, if applicable). In addition, you might have to circle some renewable sources.

Renewable Energy Sources	Non-renewable Energy Sources
Solar	Coal
Wind	Gasoline
Biofuel	Natural Gas

Note: Biofuel is a type of fuel made from **biomass** (plant matter, algae matter, or animal waste). If you burn wood in a campfire this would be considered a biofuel. Biofuel/biomass may or may not come up with your students. You do not need to bring it up if it does not come up organically.

Ask students, “Do you know of a tool we would use to transfer the energy from energy sources we burn, into useful energy sources?” Students may not know the answer to this question, and that is okay. Lead them to understand that cars (gasoline), power plants (coal and natural gas), and stoves (natural gas) are tools that can be used to harness the energy from fossil fuels.

Tell students, “Whenever one of these energy sources is burned, carbon dioxide is produced.” Fill “carbon dioxide (CO₂)” in the blank for question 11.

Effects of Power Use
In the table above, circle all energy sources that are burned to obtain energy.
11. When energy sources are burned, <u>carbon dioxide (CO₂)</u> is produced.

Note: Nuclear power is produced through a process called fission, in which atoms are split to release heat. This does not require the burning of fuel, and thus does not produce greenhouse gas emissions. However, there are other serious environmental impacts from nuclear energy, including nuclear waste.

Turn to page 29 in the class notebook under the document camera while students do the same in their notebooks. Tell students, “Scientists have found a link between carbon dioxide (CO₂) levels and temperature. Using the graphs on the top of page 29, we need to determine what that link is.” Direct students’ attention to the graph titled *Atmospheric Carbon Dioxide Levels*. Ask students, “What does this graph show?” Possible student response: how carbon dioxide levels have changed over time. Inform students that “ppm” is a unit of measurement called “parts per million,” that essentially refers to how much of a chemical is in some volume. Ask students, “Does this graph have a trend, and if so, what is it?” Possible student response: yes, there is a trend; in approximately 1900, the CO₂ levels started to drastically increase. Direct students’ attention to the graph titled *Atmospheric Temperature Anomalies*. Ask students, “What is an anomaly?” Possible student response: an anomaly is something that is different from the normal. If students are not able to generate a definition of anomaly, give them the definition. Ask students, “What does this graph show?” Possible student response: how temperatures have changed over time. Tell students (if they do not understand what the data is showing), “A monthly mean temperature anomaly is describing how much the temperature in a month deviated from the expected or normal temperature.” Ask students, “Does this graph have a trend, and if so, what is it?” Possible student response: yes, there is a trend; in 1900 more temperatures were above the average temperature.

Tell students, “We want to make a conclusion from the data.” Ask students, “What is a conclusion?” Students should reply, “A claim supported by data.” Ask students, “What claim can we make about the link between CO₂ levels and temperature?” Possible student response: as CO₂ levels increase, the temperature anomalies also increase. Direct students’ attention to question 12 and fill in the blank, “As CO₂ levels increase, the average atmospheric temperature increases.” Tell students, “We need to determine supporting data for our claim from these graphs. What two points on our graph help convince

us that this claim is true?” Possible student response: we could use a labeled point close to where the CO₂ level started drastically increasing, 1900, and a labeled point as close to today’s date as possible, 2000. Students do not have to pick these years, this is just the most convenient choice. Tell students, “We will use our rulers to help us determine the CO₂ levels and temperature anomalies for the years we just picked.” Walk students through determining the CO₂ level at 1900 (290 ppm) and 2000 (375 ppm). Have students use the same process to determine the temperature anomalies on the second graph on their own, while you do the same in the class notebook. Check answers with the class after 1 minute. Make sure students understand when the numbers are below 0, this is telling them that the temperatures were below average and when the numbers are above 0, this is telling them that the temperatures were above average.

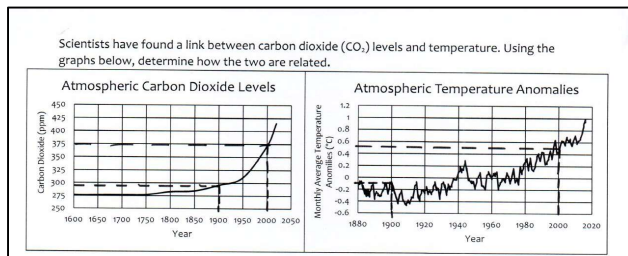

Tell students, “Now that we have our data points, we can put together our data statement.” Have one student share out a possible data statement, and have the other students use thumbs up/thumbs down to show agreement over the data statement. If the class agrees, write the data statement on the lines following the *because* in question 12. Possible student response: in 2000, there were 375 ppm of CO₂ in the atmosphere, and the temperature was 0.5°C above average, and in 1900, there were 290 ppm of CO₂ in the atmosphere, and the temperature was 0.1°C below average.

12. As CO₂ levels increase, atmospheric temperature increases, because in 2000, there were 375 ppm of CO₂ in the atmosphere and the temperature was 0.5°C above average, and in 1900, there were 290 ppm of CO₂ in the atmosphere and the temperature was 0.1°C below average.

Read question 13 to students (*If California uses non-renewable energy sources for power, what will happen to the amount of CO₂ in the atmosphere?*) Students should reply, “It will increase.” Record this answer for question 13. As students, “Why do you think this?” Possible student response: as non-renewable energy sources are burned, they produce CO₂, Therefore, the more electricity we use from non-renewable sources the more CO₂ in the air. Read question 14 to students (*What will this mean about the average atmospheric temperatures?*) Students should reply, “They will increase.” Record this for question 14. Ask students, “How do you know?” Possible student response: We know as CO₂ levels increase, the temperature increases, therefore, the more CO₂ in the air the hotter it will be. Ask students, “If we want to minimize the amount of CO₂ we are putting into the air, which types of energy sources should we try to use?” Students should reply, “Renewable energy sources.” Tell students, “In California, 47% of our electrical energy comes from **renewable sources**,” and record this for question 15.

13. If California uses non-renewable energy sources for power, what will happen to the amount of CO₂ in the atmosphere? It will increase.

14. What will this mean about average atmospheric temperatures? They will increase.

15. In California, 47% of our electrical energy comes from renewable sources.

Note: Biofuels do produce CO₂ when they are burned, but this is considered to be a carbon neutral process. While plants are alive, they take in CO₂ from the air, thus storing carbon in them. When they die/are used as fuel, they release that stored carbon back into the atmosphere as CO₂. Because the net carbon results to zero, the process is considered carbon neutral. When fossil fuels are burned, they release carbon that would normally not be released back into the atmosphere; therefore, this is not a carbon neutral process.

Bright Choices (15 minutes)

Ask students, “We know by using renewable energy sources we can minimize our impact on the amount of CO₂ we’re putting into the atmosphere. However, we cannot control the power sources being used for our electricity. Is there any way that we can minimize our impact on CO₂ production?” Possible student response: we can reduce our electricity use and use more efficient electrical devices. Record this for question 16.

Tell students, “We will now look at three different types of lightbulbs, to compare the amount of energy they use. This will help us determine which lightbulb is “best” at helping us minimize our impact on energy usage. The first lightbulb we will look at is called an LED.” Write this in the first blank on question 16, then hold the bulb under the document camera for the students to see. Tell students, “The second bulb we will look at is called a compact fluorescent lightbulb; this is abbreviated as CFL.” Write this in the second blank, then hold the bulb under the document camera for the students to see. Tell students, “The third bulb we will look at is called a halogen.” Write this in the third blank, then hold the bulb under the document camera for the students to see. Tell students, “There are some important terms we need to understand when looking at lightbulbs. The first is lumens. The number of lumens describes how much light is being given off by the lightbulb.” Record this for question 17. Ask students, “Is the number of lumens important to consider when comparing different types of lightbulbs and why?” Possible student response: yes, the number of lumens is important because we want lightbulbs that will all give off the same amount of light. Make sure students understand that the more lumens (the brighter the lightbulb), the more energy that would be used in the case of all the bulbs. Once the class agrees that this would be important to hold constant, circle *Yes* for question 17.

Tell students, “The second important term to understand is the temperature of the lightbulb. In this case, the temperature does not refer to the amount of heat produced by the lightbulb, but rather the color of the light produced by the lightbulb.” Record this for question 18. Tell students, “Changing the color given off by the lightbulb does not change the amount of energy needed for the bulb, therefore, we do not need to consider this when looking at the bulb.” Circle *No* for question 18 while students circle this in their notebooks.

Turn the class notebook to page 30 and instruct students to do the same in their notebooks. Make sure the extension cord plugged into a power strip plug (the lamp should be unplugged at this time), hanging lightbulb holder, multimeter with probes, and amp meter are all nearby. Tell students, “Each of these lightbulbs has the same number of lumens. We are going to test if they require different amounts of power. First, we will measure the voltage. All lightbulbs plug into wall outlets and our wall outlets give off the same amount of voltage. We can measure the voltage that comes out of plugs.” (**Note: This step could be dangerous for students so make sure to tell them they should under no circumstances try this at home.**) Turn the multimeter to the 200 V~ setting and place the multimeter under the document

camera. Place the black lead into one of the holes in one of the sockets on the power strip and place the red lead into the partner hole on the power strip. See picture below for example. (**Note:** it does not matter which lead goes into which hole because the current is alternating.) Have students read the voltage produced from the socket, then remove the probes. Ask students, “What is the voltage emitted in sockets?” Students should reply, “120 V.” Tell students, “LEDs and incandescent/halogen bulbs will operate directly at 120 V.” Fill this in the voltage box in the table under the LED and incandescent/halogen lightbulb.



Tell students, “Compact fluorescent lightbulbs are a little different. They need a voltage smaller than the standard 120 V to operate. In order to do this, they make use of a ballast inside the base of the bulb. This ballast scales the voltage to a smaller number.” Point to the bulky base of the CFL bulb and tell students, “This is where the ballast is housed in the bulb. Typically, 550 lumen CFLs bulbs (like the one we are using) operate at 65% of the standard wall outlet voltage which is a voltage of 78 V. Record this in the voltage in the box on the table under the CFL.

Note: The ballast adjusts the voltage so that the same amount of light is consistently given off by the bulb. Some of you may remember that when the first CFL bulbs came out, you turned them on and they were very dim and it took approximately five minutes for them to reach their full brightness. The ballasts now adjust the voltage up when the light turns on so the bulb does not have a warm-up time. Once the bulb is “warm” the voltage for 550 lumen bulbs is 65% of the wall voltage. For simplification purposes, this will not be brought up with students.

Next, tell students, “Now we have to determine if the current required by each lightbulb is different. To do this, we will use a device called an amp meter.” Place the amp meter under the document camera and turn it on to the 2 A setting. Tell students, “I will plug in each lightbulb to the socket and clamp the amp meter around the wire. The amp meter will then read the current to 3 decimal places.” Screw the LED bulb into the socket and turn it on. Tell students, “In our experiments, we measured the current in milliamps. In this experiment, we will measure current in amps. This is because we are working with larger currents now, so we need a unit larger than milliamps.” Clamp the amp meter around the wire and have students read the current to 3 decimal places. See picture below for example. Record the current in the current box under the LED lightbulb. Tell students, “Amps are abbreviated as capital ‘A.’”

Note: If you clamp around both wires you will get a current reading of 0. This is because one wire has electrons flowing in a forward direction and the other wire has electrons flowing in a backwards direction, causing the net current to read as 0 A. Once split, it does not matter which wire you choose to clamp the amp meter around.



Repeat this process for the CFL and halogen bulbs.

Will lightbulbs with the same number of lumens need different amounts of power to light?

Type of lightbulb:	LED	CFL	Incandescent/Halogen
Voltage:	120 V	78 V	120 V
Current:	0.064 A	0.115 A	0.326 A
Power:	7.7 W	9.0 W	39.1 W

Tell students, “In our experiments, we calculated power in milliwatts. In this experiment, we will calculate power in watts, which is abbreviated as capital ‘W,’ since we are working with larger amounts of power.” Have students use the calculator to calculate the power produced by each bulb and write their answers in the table, while you do the same in the class notebook. Have students check their answers with yours.

Once the class agrees on the power needed by each lightbulb, ask students, “Based on the information in the table, which lightbulb is ‘best’ and why?” Possible student response: The LED bulb is best, because it uses less power to run. Circle LED in question 19.

19. Which bulb is “best?” The LED, it uses less power to work.

Tell students, “In order to obtain all of this information without running an experiment, like we did, we can use the packaging of each lightbulb to help us compare and determine which bulb is ‘best.’” Direct students’ attention to the three *Lighting Facts* pictures on page 30 of their notebook. Tell students, “The lighting facts can be found on the back of each lightbulb package. It tells us the specifications of each bulb. The first fact sheet is for the LED, the second is for the CFL, and the third is for the halogen.” Direct students’ attention to the *Energy Used* section of the figure and tell them, “The lighting facts tells us the expected amount of energy used by each bulb. How do they compare with the energy we calculated in our experiment?” Possible student response: all bulbs need almost exactly the same calculated and expected values for energy.

Ask students, “What did we decided was important to keep the same between the lightbulbs in our experiment?” Students should reply, “The number of lumens.” Ask students, “How many lumens were in these three lightbulbs, and where did you find that information in the lighting facts?” Possible student response: the brightness on the lighting facts tells us they all have 550 lumens. Ask students, “What did we decided was not important to consider when comparing lightbulbs?” Students should reply, “The temperature/color of the lightbulb.” Ask students, “Where do you see this information in the lighting facts?” Possible student response: the light appearance. If students struggle, tell them, “Kelvin is a measurement of temperature, similar to Celsius or Fahrenheit.” Since the scale runs from “warm” to “cool” light, ask students, “Do higher temperature readings produce warmer or cooler light, and how do you know?” Possible student response: higher temperatures produce cooler light because 5,000 K is a higher temp and closer to *cool* on the scale, while 2,800 K is a lower temp and closer to *warm* on the scale. Explain to students, “The reason for this is because the sun is extremely hot, and thus sunlight is referred to as ‘natural light’ or ‘white light.’ So, lightbulbs with higher temperatures will produce what looks like white light. This is referred to as ‘cooler’ tones of light. Lights with lower temperatures will produce warmer tones and will appear more yellow.”

Ask students, “What does the life of the lightbulb tell us?” Possible student response: how long the bulb will last before burning out. Ask students, “Which of the lightbulbs has the longest and shortest life?” Students should reply, “The LED has the longest life (10 years) and the halogen has the shortest life (2.3 years).” Make sure to point out to students that these lifetimes are based on a three hour per day usage. Next, ask students, “What does the estimated yearly energy cost of the lightbulb tell us?” Possible student response: it tells us about how much it costs to run the lightbulb for three hours per day for one year. Ask students, “Which of the lightbulbs costs the least and the most amount of money to run for one year?” Students should respond, “The LED costs the least and the halogen costs the most.” Ask students, “Based on all of the information we’ve looked at, which lightbulb is ‘best’ and why?” Possible student response: the LED bulb is “best” because it uses the least power to work (7.7 W), it lasts the longest (10 years), and it costs the least amount of money to run (\$0.84). Fill this in on the class notebook for question 20 while students do the same in their notebooks

20. What does the life of the lightbulb tell us?	How long the bulb will last.
21. What does the estimated yearly energy cost of the lightbulb tell us?	How much it costs to run the lightbulb.
22. The _____ lightbulb is best because _____	LED lightbulb is best because it uses the least power to work (7.7 W), it lasts the longest (10 years), and it costs the least amount of money to run (\$0.84).

Only do this section if there is time: Ask students, “What other information is given about the CFL lighting facts that does not appear on the LED or halogen figures?” Possible student response: The CFL lighting facts says that the bulb contains mercury. Tell students, “Mercury is a very toxic gas that can fatally harm people if inhaled. If a CFL were to break, mercury gas would leak out and could harm the people in the room. Additionally, disposing of these lightbulbs is dangerous because of the hazardous material inside. If these lightbulbs are not disposed of properly, it is possible that the mercury could be absorbed into some local body of water and our entire water system would be contaminated. This is another reason why LED bulbs are ‘better’ than CFL bulbs.”

Tell students, “You can keep your notebooks, you have taught me a lot about energy and solar panels. I have learned that different devices require different powers. Solar panels can be used to generate this power, and if you know how the solar panel is set up, you can predict the amount of power it will produce. In addition, by making wise decisions about the lightbulbs we use, we can lower our carbon footprint. We will be back to do another module later in the year with you about thermal transfer in chemical reactions.”

Clean-Up:

1. Leave notebooks with students.
2. Make sure all calculators have their covers on and are placed back into the calculator box.
3. Place lamp, extension cord, and power strip back into the bag.
4. Put the green and white LED cups, lightbulbs, amp meter, multimeter, and probes back into the tie to standards box.
5. Place all other materials into the lead box and bring them back to UCSB.
6. Remove all materials from your lab coat pockets, remove your nametag, unroll your lab coat sleeves, and put your lab coat into the dirty clothes bag at UCSB.

Extra Practice Solutions:

EXTRA PRACTICE

Directions:

Circle if the statement is a CLAIM, DATA, or an OPINION.

1. a. The Nile River is 6,650 km long and the Amazon River is 6,575 km long. Claim Data Opinion
- b. McDonalds French fries have more salt than In-N-Out French fries. Claim Data Opinion
- c. Dogs weighing over 50 lbs. sleep more than smaller dogs. Claim Data Opinion
- d. 30 people used a black pen and 12 people used a blue pen. Claim Data Opinion
- e. Peaches are the most delicious fruit. Claim Data Opinion
- f. The car door handle was observed to be warmer after sitting in sunlight. Claim Data Opinion
- g. The tallest building in the world is in Dubai. Claim Data Opinion
- h. The more interesting the story, the longer the student will read. Claim Data Opinion

Directions for annotating: Underline control(s), circle changing variables, and box information about data collection.

2. a) Annotate the following results table.

Variables		Trial 1	Trial 2	Trial 3
<u>Coal Amount:</u>		1,500 Mg	2,500 Mg	3,500 Mg
<u>Number of Generators:</u>		3		
<u>Water Amount:</u>		4,400 L		
Data		Trial 1	Trial 2	Trial 3
Power (MW):		51 MW	67 MW	93 MW
Other:		Air around plant is light brown	Air around plant is brown	Air around plant is dark brown

b) Can this group make a conclusion? YES NO I DON'T KNOW

c) Annotate the following possible conclusion.

Possible Conclusion: When less coal is burned in the power plant the air will be less polluted, because when the amount of coal was 1,500 Mg the air around the plant was observed to be light brown and when the amount of coal was 3,500 Mg the air around the plant was observed to be dark brown.

d) Is this a correct conclusion for the results table? YES NO I DON'T KNOW
If NO, what is wrong with the conclusion?

3. a) Annotate the following results table.

Variables		Trial A	Trial B	Trial C
<u>Coal Amount:</u>		2,000 Mg	2,500 Mg	3,000 Mg
<u>Number of Generators:</u>		4		
<u>Water Amount:</u>		4,800 L	4,400 L	4,000 L
Data		Trial A	Trial B	Trial C
Power (MW):		27 MW	60 MW	92 MW
Other:		Air around plant is light brown	Air around plant is light brown	Air around plant is light brown

b) Can this group make a conclusion? YES NO I DON'T KNOW

c) Annotate the following possible conclusion.

Possible Conclusion: The less water used in the power plant the higher the power, because when 4,800 L of water were used, 27 MW of power were produced, and when 4,000 L of water were used, 92 MW of power were produced.

d) Is this a correct conclusion for the results table? YES NO I DON'T KNOW
If NO, what is wrong with the conclusion? More than 1 changing variable.

4. a) Annotate the following results table.

Variables		Trial A	Trial B	Trial C
<u>Coal Amount:</u>		2,500 Mg		
<u>Number of Generators:</u>		4		
<u>Water Amount:</u>		4,800 L	4,400 L	4,000 L
Data		Trial A	Trial B	Trial C
Power (MW):		42 MW	58 MW	75 MW
Other:		Air around plant is light brown	Air around plant is light brown	Air around plant is light brown

b) Can this group make a conclusion? YES NO I DON'T KNOW

c) Annotate the following possible conclusion.

Possible Conclusion: When the water amount was 4,400 L the power was 75 MW and when the water amount was 4,800 L the power was 42 MW because the more water used in the power plant, the lower the power.

d) Is this a correct conclusion for the results table? YES NO I DON'T KNOW
If NO, what is wrong with the conclusion? Claim and data switched.

Directions: Some engineers wanted to know how changing the percentage of water amount would affect the power produced by a power plant. They did 3 experiments, using a different coal amounts each time, and plotted most of their data on a graph. Answer question 5 using the graph below.

5. a) Annotate the graph.

b) Plot the data points from the chart below on the graph using circles (O) as markers.

Coal Amount: 2,500 Mg	
% of Water	Power (MW)
20	80
40	60
60	25
78	5

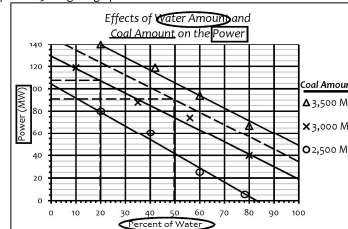

c) Draw trend lines on the graph for each data set.

d) In general, for all coal amounts, what happens as the percentage of water amount increases?

As percent water amount increases, power decreases

e) What will the power be if a power plant uses 3,000 Mg of coal and 20% water amount?

106 MW

f) What will the power be if a power plant uses 3,250 Mg of coal and 50% water amount?

90 MW