

Lead Information Packet

Module 2: Chromatography

5th Grade

This document is not intended to give you all of the information you need to lead the module. It is only intended to be a reference during the module. You can find the complete instructions at scitrek.chem.ucsb.edu/module as well as the notebook and picture packet used during the module.

Note: We **highly recommend** teachers give the final conclusion assessment outside of SciTrek sessions.

Important Things to Remember During the Module

1. You are responsible for keeping track of time in the classroom and making sure **all** activities run smoothly. There will be a time card in the lead box with suggested times to start/stop each activity.
2. You are responsible for keeping volunteers and students on track.
3. Walk around during times volunteers are working with students and help struggling groups/subgroups.

Types of Documents:

Notebook:

One given to every student and is filled out by the student. The lead will use a notebook to write in as an example for students. The notebook the lead uses is referred to as the class notebook in these instructions.

Notepad:

One given to every group and is filled out by the volunteer. In these instructions, the examples are narrower and taller than the notebook pages.

Picture Packet:

One per class that, if needed, the lead fills out. In these instructions, the examples are the same size as the notebook pages but are labeled.

In these instructions, all other example documents are labeled.

Day 1: Conclusion Assessment/Observations/Variables

Schedule: You are responsible for **BOLD** sections

Introduction (SciTrek Lead) – 2 minutes

Conclusion Assessment (SciTrek Lead) – 10 minutes

Observation Discussion (SciTrek Lead) – 2 minutes

Observations (SciTrek Volunteers) – 26 minutes

Variable Discussion (SciTrek Lead) – 5 minutes

Variables (SciTrek Volunteers) – 12 minutes

Wrap-Up (SciTrek Lead) – 3 minutes

Preparation:

1. Make sure volunteers are passing out nametags.
2. Make sure volunteers are setting up for the initial observation.
3. Set up the document camera for the class question (notebook, front cover).
4. Pass out the conclusion assessments.

Introduction: (2 minutes – Full Class – SciTrek Lead)

- Allow volunteers to introduce themselves.
- Introduce the module.

Conclusion Assessment: (10 minutes – Full Class – SciTrek Lead)

- Page 1 (top): Read the two questions aloud and have students fill them in.
- Page 1 (bottom): Read each statement and have students circle whether the statement is a claim, data, or opinion
- Page 2 (top): Have students underline controls, circle changing variable(s), and box information about data collection on the results table. Then, have students decide if the group could make a conclusion.
- Page 2 (bottom): Read each statement and have students identify if the statement is a claim or data and then circle if statement is a correct claim, correct data, or incorrect based on the results table.
- Page 3: Repeat the process for page 3.
- Collect assessments.

Observation Discussion: (2 minutes – Full Class – SciTrek Lead)

- Review the definition of an observation (a description using your five senses).
- Have students move to their groups.
 - If a student does not have a nametag, identify the group color with the least number of students in it and write the student's name on one of the extra nametags in the lead box using that color of marker.

Observations: (26 minutes – Groups – SciTrek Volunteers)

- Walk around and help groups who are struggling.
- Make sure groups are moving along and only spending ~6 minutes on the experimental set-up, ~2 minutes setting up the experiment, ~5 minutes with the strip in the water (they should **not** remove their strip from the water at time 1), and ~11 minutes measuring the smear.

OBSERVATIONS			
Experimental Set-Up: <u>Black Mr. Sketch pen</u> <u>graduated cylinder with 2 mL of water</u> <u>paper 11.5 cm high with line on it at 2 cm</u> <u>timer</u> <u>5 boxes of crayons</u> <u>test tube and test tube holder</u>			
	Time 0	Time 1	Time 2
Time:	0 s	3 min 20 s	7 min 10 s
Picture:			
Measurements/ Observations:	<ul style="list-style-type: none"> • Small black dot on line (2cm) • Strip put into test tube with water 	<ul style="list-style-type: none"> • Dot turned into smear • Black turned into blue and red 	<ul style="list-style-type: none"> • Smear got longer (3.0 cm) • Water went up paper (5.0 cm) • Blue, pink, red and orange all seen

2

OBSERVATIONS			
Experimental Set-Up: <u>Black Mr. Sketch pen</u> <u>Graduated cylinder with 2 mL of water</u> <u>Paper 11.5 cm high with line on it at 2 cm</u> <u>Timer</u> <u>5 boxes of crayons</u> <u>Test tube and test tube holder</u>			
	Time 0	Time 1	Time 2
Time:	0 s	3 min 20 s	7 min 10 s
Picture:			
Measurements/ Observations:	<ul style="list-style-type: none"> • Small black dot on line (2 cm) • Strip put into test tube with water 	<ul style="list-style-type: none"> • Dot turned into smear • Black turned into blue and red 	<ul style="list-style-type: none"> • Smear got longer (3.0 cm) • Water went up paper (5.0 cm) • Blue, pink, red, and orange all seen

3

Variable Discussion: (5 minutes – Full Class – SciTrek Lead)

- Have groups share what they did and learned.
 - Groups put a strip of paper with a black dot on it into a test tube with water; over time, the dot spread out into a ‘smear’ that showed many different colors.
- Ask students, “What is the most interesting thing you observed?” Have them decide as a class to investigate the question: What variables affect smears?
 - Write this class question on the front cover of the class notebook and have students copy it onto their notebooks.
- Review the definition of a variable (something in an experiment that can be changed).
- Explore one possible changing variable with the class and have students share how and why they believe this variable might affect the height and colors of the smear.

Variables: (12 minutes – Groups – SciTrek Volunteers)

- Walk around and help groups who are struggling.
- Make sure volunteers are having their group come up with three possible variables, as well as how and why they believe these variables might affect smears.
- Make sure students are generating at least one additional variable by themselves.

VARIABLES	
Variable	How will changing this variable affect the smears?
Pen Type	Smears will be longer if the pen type is _____. Pen type will _____ the colors of the smear.
Paper Type	Smears will be longer if the paper type is _____. Paper type will _____ the colors of the smear.
Liquid Type	Smears will be longer if the liquid type is _____. Liquid type will _____ the colors of the smear.
Choose your own!	

3

VARIABLES	
Variable	How will changing this variable affect the smears?
Pen Type	Smears will be longer if the pen type is not permanent. Pen type will change the colors of the smear.
Paper Type	Smears will be longer if the paper type is more absorbent. Paper type will not change the colors of the smear.
Liquid Type	Smears will be longer if the liquid type is thinner. Liquid type will not change the colors of the smear.
Time	Smears will be longer if the time is longer. Time will change the colors of the smear.
Pen Color	Pen color will not affect the height of the smear. Pen color will change the colors of the smear.

3

Wrap-Up: (3 minutes – Full Class – SciTrek Lead)

- Have each group share one variable with the class, as well as how and why they think this variable will (or will not) affect smears.
- Go over what students will do next session.

Day 2: Question/Materials Page/Experimental Set-Up/Procedure

Schedule: You are responsible for **BOLD** sections

- Introduction (SciTrek Lead) – 13 minutes**
- Question (SciTrek Volunteers) – 10 minutes
- Materials Page (SciTrek Volunteers) – 7 minutes
- Experimental Set-Up (SciTrek Volunteers) – 8 minutes
- Procedure (SciTrek Volunteers) – 19 minutes
- Wrap-Up (SciTrek Lead) – 3 minutes**

Preparation:

1. Make sure volunteers are setting out notebooks in such a way that allows students within the same subgroup to work together.
2. Set up the document camera for the Day 1 strip (picture packet, page 1), question (notebook, page 4), materials page (lead box), and experimental set-up (notebook, page 5).

Introduction: (13 minutes – Full Class – SciTrek Lead)

- Review the class question, as well as what students did and learned last session.
 - Show students the Day 1 strip (picture packet, page 1).
- Review experimental considerations with the class (notebook, page 4, top):
 - *You will only have access to the materials on the materials page.*
 - *The strips of paper cannot be in the liquid for more than 5 minutes.*
 - *All strips of paper must be put into the liquid at the same time.*
- Design an example experiment with the class.
 - For the changing variables, pick a variable with measurement values (Ex: liquid amount) and one without measurement values (Ex: pen color; notebook, page 4).
 - Show students how to write the question.
 - If we change the liquid amount and pen color, what will happen to the height and color of the smear?
 - Fill out the materials page for the example experiment (lead box).
 - Read step 1 and have students tell you what to do for each bolded word (underline controls and circle changing variables).
 - Go through the list of general materials and check them off.
 - Read steps 2 and 3. You should choose the control values, but let students choose the four changing variable values.
 - Remind students to pick changing variable values that are spread out.
 - Write trial letters next to changing variables values (Ex: Red A).
 - Fill out the experimental set-up for the example experiment (only *Trials A* and *B* for the changing variable; notebook, page 5).
 - Draw an additional line under the controls list for another control and its value.
 - If students choose to change three variables, there will be one additional blank for controls. Lead students to come up with “cap placement/on.”
 - Read the example procedure step that includes the changing variable (notebook, page 6, top).

Experimental Considerations:

1. You will only have access to the materials on the materials page.
2. The strips of paper cannot be in the liquid for more than 5 minutes.
3. All strips of paper must be put into the liquid at the same time.

Changing Variable(s) (Independent Variable(s))

You will get to perform two experiments. For your first experiment, decide which variable(s) (max three) you would like to test. For each changing variable you select, discuss with your subgroup why you think that variable will affect the smear.

Changing Variable 1: Liquid Amount
 Discuss with your subgroup how you think **changing variable 1** will affect the smear.

Changing Variable 2 (optional): Pen Color
 Discuss with your subgroup how you think **changing variable 2** will affect the smear.

Changing Variable 3 (optional): _____
 Discuss with your subgroup how you think **changing variable 3** will affect the smear.

QUESTION

Question our subgroup will investigate:

- If we change the liquid amount and pen color
insert each changing variable (independent variable)
 _____,
 what will happen to the height and color of the
insert what you are measuring/observing (dependent variable)
smear _____?

SciTrek Member Approval: _____

Get a materials page from your volunteer and fill it out before moving onto the experimental set-up.

4

Color (circle one): Orange Blue Green
Group Number (circle one): 1 2 3

MATERIALS PAGE

You will only have access to the following materials.

- For each bolded word, underline it if it is a control and circle it if it is a changing variable. Example control: Liquid Type, Example changing variable: Pen Type
- For variables that are controls, choose 1 value.
- For variables that are changing variables, choose 4 values and write the trial letter (A,B,C,D or E,F,G,H) next to each value. Example: Crayola A

General Materials:
 4 test tubes with caps test tube rack timer
 2 rulers 2 droppers 2 graduated cylinders

Liquid Type:
 rubbing alcohol (RA) soap vinegar
 water

Liquid Amount: A) 1 mL, B) 20 mL, C) 5 mL, D) 10 mL
 Any amount up to 20 mL (original liquid amount = 2 mL)

Paper Type:
 original paper coffee filter copy paper paper towel
 graph paper newspaper construction paper

Pen Type:
 Mr. Sketch (original) Crayola Expo
 Sharpie Rose Art BIC (Black Only)
 Dry Erase (Black Only) Paper Mate (Black Only)

Pen Color:
 red A orange yellow D green
 blue B purple black (original) brown
 The following colors can only be chosen if your pen type is Mr. Sketch.
 light pink dark pink light blue light green C

Initial Dot Height: 2 cm
 Any height up to 11.5 cm (original dot height = 2 cm)

Time: 5 min
 Any time up to 5 minutes

Materials Page

EXPERIMENTAL SET-UP

Write your changing variable(s) (Ex: pen color) and the values (Ex: blue) you will use for your trials under each strip of paper.

A

B

C

D

Changing Variable(s):

- Liquid Amount : 1 mL 20 mL _____
- Pen Color : Red Blue _____
- _____ : _____

Controls (variables you will hold constant):
 Write your controls and the values you will use in all your trials (control/value, Ex: container/test tube).

<u>Container</u> / <u>Test Tube</u>	<u>Paper Type</u> / <u>Original</u>
<u>Time</u> / <u>5 min</u>	<u>Pen Type</u> / <u>Mr. Sketch</u>
<u>Liquid Type</u> / <u>Water</u>	<u>Initial Dot</u> / <u>2 cm</u>
	<u>Height</u>
	<u>Cap Placement</u> / <u>On</u>

SciTrek Member Approval: _____

5

Question: (10 minutes – Subgroups – SciTrek Volunteers)

- Walk around and help subgroups who are struggling.
- Encourage subgroups to pick different changing variables.
- **Make sure volunteers are not giving advice on how many changing variables to use.**
- Make sure, for the second part of the question (*what you are measuring/observing*), students are specific (they should write, “the height and color of the smear” and not just “the smear”).

Materials Page: (7 minutes – Subgroups – SciTrek Volunteers)

- Walk around and help subgroups who are struggling.
- Make sure subgroups are underlining their controls and circling their changing variable(s).
- Make sure subgroups are filling out the materials page correctly and completely.

Experimental Set-Up: (8 minutes – Subgroups – SciTrek Volunteers)

- Walk around and help subgroups who are struggling.
- Make sure, within one subgroup, all students have the same order for their changing variable(s) values.
- Make sure all control blanks are filled out.

Procedure: (19 minutes – Subgroups – SciTrek Volunteers)

- Walk around and help subgroups who are struggling.
- Make sure procedures are concise, but still include all values of the controls and changing variable(s), as well as the data that will be collected.

Wrap-Up: (3 minutes – Full Class – SciTrek Lead)

- Go over what students will do next session.

<p>PROCEDURE</p> <p>Procedure Note: <small>Make sure to include all values of your changing variable(s) in the procedure (Ex: For a subgroup that decided to change pen color, one step would be: Put colored dot with Mr. Sketch pens A) red, B) blue, C) green, and D) yellow on original paper at 2 cm.)</small></p> <ol style="list-style-type: none"> 1. <u>Fill 4 test tubes with 5 mL of A) RA, B) vinegar, C) water, and D) soap.</u> 2. <u>Draw dots on original papers at A) 1 cm, B) 7 cm, C) 3 cm, and D) 5 cm with a black A) Mr. Sketch, B) Expo, C) Bic, and D) dry erase pen.</u> 3. <u>Put papers in test tubes and put cap on.</u> 4. <u>Wait 5 minutes.</u> 5. <u>Remove papers.</u> 6. <u>Measure smear heights and observe smear colors.</u> 	<p>Note: Procedure does not match the lead experiment</p>
--	--

Day 3: Results Table/Experiment/Graph/Conclusion Activity

Schedule: You are responsible for **BOLD** sections

- Introduction (SciTrek Lead) – 8 minutes**
- Results Table (SciTrek Volunteers) – 3 minutes
- Experiment (SciTrek Volunteers) – 17 minutes
- Graph (SciTrek Volunteers) – 10 minutes
- Conclusion Activity (SciTrek Lead) – 20 minutes**
- Wrap-Up (SciTrek Lead) – 2 minutes**

Preparation:

1. Make sure volunteers are setting out notebooks.
2. Make sure volunteers are setting up for the experiment.
3. Set up the document camera for the filled-out results table (picture packet, page 2), graph (notebook, page 8), and conclusion activity (notebook, pages 9 and 10).

Introduction: (8 minutes – Full Class – SciTrek Lead)

- Review the class question, as well as what students did and learned last session.
- Show students how to fill out the results table (picture packet, page 2).
- Use the checklist (notebook, page 8, top) to go over how to graph results.
 - Use the filled-out results table (picture packet, page 2) to fill out the graph (notebook, page 8).
 - Stress the importance of step 4 to ensure students’ graphs are in increasing order.
 - Only graph the results for the two smallest smear heights (0 cm and 7 cm).
- Show students how to label their test tubes with a blue wet erase pen.

RESULTS
Table

Fill out the table for each of your trials. For the variables that remain constant, write the value in trial A. Then, draw an arrow through each box indicating that this variable is a control.

Variables	Trial A	Trial B	Trial C	Trial D
Container:	Test Tube			
Time:	5 min			
Liquid Type:	RA	Soap	Water	Vinegar
Liquid Amount:	2 mL			
Paper Type:	Original			
Pen Color:	Red	Blue	Light Green	Yellow
Pen Type:	Mr. Sketch			
Initial Dot Height:	2 cm			
Cap Placement:	On			
Predictions	Trial A	Trial B	Trial C	Trial D
<small>Put a "T" in the trial that will give the tallest smear and an "S" in the trial that will give the shortest smear.</small>	T		S	
Data	Trial A ³	Trial B ¹	Trial C ⁴	Trial D ²
Smear Height:	7.5 cm	0 cm	7.5 cm	7 cm
Liquid Height:	9.5 cm	2 cm	9.5 cm	9 cm
Other:	Pink, Red	Liquid did not reach dot	Yellow	Blue, Green, Yellow

The independent variable(s) is(are) the changing variable(s) and the dependent variables are the final measurements/observations.

RESULTS
Graph

Set up your graph. (Check off the steps as you complete them.)

- Label the y-axis (vertical) with what you measured, including units (Ex: Smear Height (cm)).
- Determine an appropriate scale which will allow you to graph all of your data points and write the numbers on the given lines.
- Label the x-axis (horizontal) with your changing variable(s) #1, #2, and #3 (Ex: Liquid Type). Changing variable #2 and #3 will only be filled in if you have 2 or 3 changing variables.
- On your results table, label your measurements from 1 to 4, with 1 being the trial with the smallest measurement, and 4 being the trial with the largest measurement.

Plot your data in increasing order.

- Write the changing variable value(s) (Ex: Soap) for the trial that you labeled 1 under the first column.
- Graph your data for that trial and write the measurement above the bar.
- Repeat the process for the other trials.

Liquid Type: Soap Vinegar _____

Pen Color: Blue Yellow _____

Results Table: (3 minutes – Subgroups – SciTrek Volunteers)

- Walk around and help subgroups who are struggling.
- Make sure students are underlining controls, circling the changing variable(s), and boxing data collection boxes.
- Make sure control values are written in the *Trial A* box with an arrow through the rest of the trials' boxes, while changing variable(s) values are written in each trial's box.
- Make sure students are making predictions for which trial they think will produce the shortest (S) and tallest (T) smears.

Experiment: (17 minutes – Subgroups – SciTrek Volunteers)

- Walk around and help subgroups who are struggling.
- Make sure students are labeling the test tubes with a blue wet erase pen.
- Make sure students are drawing their initial dot height line and labeling the strips with pencil.
- Make sure students are putting all the strips into the test tubes at the same time.
- Make sure volunteers are removing all of the liquids as soon as students are done with them.
- Make sure students are drawing the liquid line, with pencil, as soon as the strips come out of the test tubes.

Graph: (10 minutes – Subgroups – SciTrek Volunteers)

- Walk around and help subgroups who are struggling.
- If none of the dots smeared, students can graph the liquid height instead of smear height.
 - If this is the case, the subgroup should go back and revise their question to be about liquid height.
- Make sure students are graphing their data from shortest smear/liquid height to tallest smear/liquid height.

- Make sure students have their changing variable values (Ex: water), not the trial letters (Ex: trial B), on the x-axis.
- Make sure students are writing the numerical value of the smear/liquid height on top of each column.

Conclusion Activity: (20 minutes – Full Class – SciTrek Lead)

- **Make sure to start the conclusion activity at least 15 minutes before the end of the session, even if students are not done with their graphs.**
- Review the definition of a conclusion (claim supported by data; notebook, page 9).
- Review the definition of a claim (a statement that can be tested).

- Have students give two examples of claims.

- Review the forms of data (observations and measurements).

- Read each statement.

- Have students independently circle if each statement is a claim, data, or opinion.
- For each statement have a student share their answer and then, have the rest of the class vote, using thumbs up/down, if the agree/disagree with the student. Once a class consensus has been reached, box the answer.
 - Students should not erase their original answers.
- When applicable, underline controls (descriptive numbers), box data collection, and double underline opinions.
- For claim statements, have students tell you what data would need to be collected to back up the claim.
- For data statements, have students tell you the claim that it could be paired with to make a conclusion.

- a. McDonald's served 100 customers, and Taco Bell served 75 customers

- Data

- Possible Claim: McDonalds serves more customers than Taco Bell

- b. blue is the best color

- Opinion

- c. butterflies that are larger than 15 cm, are attracted to bright colors

- Claim

- 15 cm is not a data measurement. It is called a descriptive number because it describes a control in the experiment.

- Possible Data: counting the number of butterflies that land on bright colored paper compared to the number of butterflies that land on black or brown paper.

- d. ice was observed floating on water

- Data

- Possible Claim: ice is less dense than water

- e. people buy more pizza than hamburgers

- Claim

SCIENTIFIC PRACTICES
Conclusions

1. Directions: Fill in the missing definition.

- Conclusion: a claim supported by data
 - **Claim:** A statement that can be tested. The explanation of the data, the first part of a conclusion.
 - Ex: Cats, on average, weigh less than dogs
 - **Data:** Evidence collected from experiment(s) (measurements or observations), the second part of a conclusion.
 - Ex: the average weight of a dog is 14 kg, and the average weight of a cat is 5 kg.

2. Directions: Circle if the statement is a CLAIM, DATA, or an OPINION.

a. McDonald's served 100 customers and Taco Bell served 75 customers Claim Data Opinion

b. blue is the best color Claim Data Opinion

c. butterflies that are larger than 15 cm, are attracted to bright colors Claim Data Opinion

d. ice was observed floating on water Claim Data Opinion

e. people buy more pizza than hamburgers Claim Data Opinion

f. the average male blue whale weighs 91,000 kg, while the average female blue whale weighs 122,000 kg Claim Data Opinion

g. the tastier the fruit, the more bugs on the fruit Claim Data Opinion

Circles are your initial thoughts and boxes are the correct answer.

9

- Possible Data: count the number of people that buy pizza and hamburgers
 - *f. the average male blue whale weighs 91,000 kg, while the average female blue whale weighs 122,000 kg*
 - Data
 - Possible Claim: female blue whales weigh more than male blue whales
 - *g. the tastier the fruit the more bugs on the fruit*
 - Opinion
- Read the directions (notebook, page 10).
 - Have students make matches between claims and data and then share out matches.
 - *Correct matches*
 - *Sony TVs are brighter than Samsung TVs, because Sony TVs give off 20 lumens of light and Samsung TVs give off 10 lumens of light.*
 - *The color purple is made from blue and red, because when blue and red paint were mixed the paint was observed to turn purple.*
 - Discuss why the statement *Wind turbines produce less energy than solar panels in California* does not match with *wind turbines produce 6,000 MW of energy and solar panels produce 5,000 MW of energy.*
 - Discuss why only the claim can be changed when the data and claim do not match.
 - If there is additional time you can continue on to the next page of the conclusion activity.

SCIENTIFIC PRACTICES
Conclusions

3. **Directions:** Draw a line connecting claims with the correct data. If there is no data that supports the claim, do not draw a line.

Claim	because	Data
1. People read more from electronic devices than books	/	a. Sony TVs give off 20 lumens of light and Samsung TVs give off 10 lumens of light.
2. Sony TVs are brighter than Samsung TVs	/	b. when blue and red paint were mixed the paint was observed to turn purple.
3. The color purple is made from blue and red	/	c. wind turbines produce 6,000 MW of energy and solar panels produce 5,000 MW of energy in California.
4. Wind turbines produce less energy than solar panels in California		d. the speed of light is measured to be $3 \times 10^8 \frac{m}{s}$.

10

Wrap-Up: (2 minutes – Full Class – SciTrek Lead)

- Go over what students will do next session.

Day 4: Conclusion Activity/Conclusion/Question/Materials Page/Experimental Set-Up/Procedure

Schedule: You are responsible for **BOLD** sections

- Introduction (SciTrek Lead) – 2 minutes**
- Conclusion Activity (SciTrek Lead) – 25 minutes**
- Conclusion (SciTrek Volunteers) – 5 minutes
- Question (SciTrek Volunteers) – 5 minutes
- Materials Page (SciTrek Volunteers) – 5 minutes
- Experimental Set-Up (SciTrek Volunteers) – 5 minutes
- Procedure (SciTrek Volunteers) – 11 minutes
- Wrap-Up (SciTrek Lead) – 2 minutes**

Preparation:

1. Make sure volunteers are passing out notebooks.
2. Set up the document camera for the conclusion activity (notebook, pages 11-13).

Introduction: (2 minutes – Full Class – SciTrek Lead)

- Review the class question, and what students did, and learned, last session.
- Review what they learned about conclusions.
 - What is a conclusion?
 - Claim supported by data
 - What is a claim?
 - Statement that can be tested
 - What type of information can be used for data?
 - Measurements, observations or calculations.

Conclusion Activity: (25 minutes – Full Class – SciTrek Lead)

- Have students identify and underline the controls, circle the changing variable(s), and box information about data collection on the results table (notebook, page 11).
- Read each statement.
 - As a class, discuss whether each statement is a claim or data and write a “C” or “D” on the line.
 - Have students help you annotate the statement by underlining controls, circling changing variables (every claim statement will have a changing variable), and boxing data.
 - Have students look at the results table to determine whether the statement is a correct claim, correct data, or incorrect.
 - Statements are incorrect if they are not supported by the results table, or if they have not been tested.
- Questions used for statements that are claims:
 - What type of statement is this and how do you know?
 - What would need to be the changing variable for this claim to be correct?
 - Is that variable a changing variable in the experiment?
 - If answer is yes:
 - Is this claim consistent with the data?
 - Is the statement a correct claim, correct data, or incorrect?
 - If answer is no:
 - Is the statement a correct claim, correct data, or incorrect?
- Questions used for statements that are data:
 - What type of statement is this and how do you know?
 - Is the data correct based on the results table?
 - Is this statement a correct claim, correct data, or incorrect?
- *a. the paper type affects the height the liquid travels up the paper*
 - Claim/Incorrect (Variable Held Constant)
- *b. black pen types are made up of different dye colors*
 - Claim/Correct Claim
- *c. when a black dot sits in water for 5 min, different pen types give different smear heights*
 - Claim/Correct Claim
 - The number in this claim is a descriptive number.

SCIENTIFIC PRACTICES
Conclusions

Variables	Trial A	Trial B
<u>Time:</u>	5 min	→
<u>Liquid Type:</u>	Water	→
<u>Liquid Amount:</u>	2 ml	→
<u>Paper Type:</u>	Original	→
<u>Pen Color:</u>	Black	→
<u>Pen Type:</u>	Mr. Sketch	Crayola
<u>Initial Dot Height:</u>	2 cm	→
Data	Trial A	Trial B
Smear Height:	3 cm	2 cm
Liquid Height:	5 cm	4 cm
Other:	Green Blue Red	Yellow Blue Red

4. Directions: **Step 1:** Identify the following statements as either CLAIM or DATA and write a C or D on the line. **Step 2:** Look at the results table and circle if the statement is a correct claim, correct data, or incorrect. Statements are INCORRECT if the statement does not agree with the data table or has not been tested.

	Step 1: Statement Type: C or D	Step 2: Based on the table, is the statement a correct claim, correct data, or incorrect?	
a. the <u>paper type</u> affects the height the liquid travels up the paper	C	Correct Claim Correct Data	Incorrect
b. <u>black pen types</u> are made up of different dye colors	C	Correct Claim Correct Data	Incorrect
c. when a <u>black dot sits in water for 5 min</u> , different <u>pen types</u> give different smear heights	C	Correct Claim Correct Data	Incorrect
d. the <u>black Crayola</u> was observed to contain <u>green</u> dye	D	Correct Claim Correct Data	Incorrect

What data can be used to support claim b above? Black Mr. Sketch was observed to contain green, blue, and red dyes while black Crayola was observed to contain yellow, blue, and red dyes.

- d. the black Crayola was observed to contain green dye
 - Data/Incorrect
- Have students determine data that backs up claim b.
 - Black Mr. Sketch was observed to contain green, blue, and red dyes while black Crayola contained yellow, blue, and red dyes.
- Have students repeat the process for page 12.
- a. the stronger the pen odor the larger the smear height
 - Claim /Incorrect (No Data Gathered)
- b. the black pen had a smear height of 3 cm and the red pen had a smear height of 1.5 cm
 - Data/Correct Data
- c. black and red pens are made from green dye
 - Claim/Incorrect (Inconsistent with Data)
- d. the thicker the liquid the shorter the smear height
 - Claim/Incorrect (More than One Changing Variable)
- Go over the two questions on the bottom of page 12.
- Have students identify and underline the controls, circle the changing variable(s), and box information about data collection, and then determine whether the scientists can make a conclusion (notebook, page 13).
- Tell students, "You will now determine whether a conclusion can be made from your first experiment, then design another experiment."

SCIENTIFIC PRACTICES
Conclusions

Variables	Trial A	Trial B
Time:	5 min	4 min
Liquid Type:	Water	Soap
Liquid Amount:	2 ml	
Paper Type:	Original	
Pen Color:	Black	Red
Pen Type:	Mr. Sketch	
Initial Dot Height:	2 cm	
Data		
	Trial A	Trial B
Smear Height:	3 cm	1.5 cm
Liquid Height:	5 cm	3.5 cm
Other:	Green Blue Red	Red Orange

5. **Step 1:** Statement Type: C or D **Step 2:** Based on the table, is the statement a correct claim, correct data, or incorrect?

a. the stronger the pen odor the larger the smear height C Correct Claim Correct Data **Incorrect**

b. the black pen had a smear height of 3 cm and the red pen had a smear height of 1.5 cm D Correct Claim **Correct Data** Incorrect

c. black and red pens are made from green dye C Correct Claim Correct Data **Incorrect**

d. the thicker the liquid the shorter the smear height C Correct Claim Correct Data **Incorrect**

If no claim can be made from the data state why not. No claim can be made because there is more than one changing variable.

If no claim can be made from the results, can you make a conclusion?
 YES NO

SCIENTIFIC PRACTICES
Conclusions

6. **Directions:** Decide if a claim/conclusion can be made for each of the following results tables and graph.

Table A

Variables	Trial A	Trial B
Time:	3 min	2 min
Pen Type:	Crayola	Mr. Sketch
Pen Color:	Black	
Paper Type:	Original	
Liquid:	Water	
Liquid Amount:	2 ml	4 ml
Data		
	Trial A	Trial B
Smear Height:	3 cm	4 cm

Can this scientist make a claim/conclusion? No

Table B

Variables	Trial A	Trial B
Time:	5 min	
Pen Type:	Mr. Sketch	
Pen Color:	Blue	
Paper Type:	Newspaper	Original
Liquid:	Vinegar	
Liquid Amount:	5 ml	
Data		
	Trial A	Trial B
Smear Height:	3.5 cm	4 cm

Can this scientist make a claim/conclusion? Yes

Table C

Variables	Trial A	Trial B
Time:	5 min	
Pen Type:	Rose Art	Exp o
Pen Color:	Black	
Paper Type:	Original	
Liquid:	Soap	
Liquid Amount:	2 ml	
Data		
	Trial A	Trial B
Smear Height:	3 cm	3 cm

Can this scientist make a claim/conclusion? Yes

Graph D

Can this scientist make a claim/conclusion? No

Making a Conclusion from Your Data

How many changing variables did you have in your experiment? 3

Can you make a conclusion from your data? YES NO

IF NO

Why? I cannot make a conclusion because my experiment had more than one changing variable.

IF YES

CONCLUSION

We can conclude _____ claim

because _____ data (measurement/observation)

SciTrek Member Approval DF

Conclusion: (5 minutes – Subgroups – SciTrek Volunteers)

- If subgroups have not finished their graph **do not** make them go back and finish it. Most likely these subgroups will not be able to make a conclusion; therefore, they will not use the data from their first experiment.
- Walk around and help subgroups who are struggling.
- Subgroups who can make a conclusion will need more help than those who cannot.
 - If a subgroup can make a conclusion, make sure they are making a claim, and using specific data to support that claim.

Question: (5 minutes – Subgroups – SciTrek Volunteers)

- Walk around and help subgroups who are struggling.
- Make sure subgroups are only picking one changing variable.
- Encourage subgroups to pick different changing variables.
- Make sure, for the second part of the question (what you are measuring/observing), students are specific (they should write, “the height and color of the smear” and not just “the smear”).

<p style="text-align: right;">Color (circle one): Orange <input checked="" type="radio"/> Blue <input type="radio"/> Green</p> <p style="text-align: right;">Group Number (circle one): 1 <input type="radio"/> <u>2</u> <input type="radio"/> 3</p> <p style="text-align: center;">MATERIALS PAGE</p> <p>You will only have access to the following materials.</p> <ol style="list-style-type: none"> For each bolded word, underline it if it is a control and circle if it is a changing variable. Example control: <u>Liquid Type</u>. Example changing variable: <u>Pen Type</u>. For variables that are controls, choose 1 value. For variables that are changing variables, choose 4 values and write the trial letter (A,B,C,D or E,F,G,H) next to each value. Example: <input checked="" type="checkbox"/> Crayola A <p>General Materials:</p> <table style="width: 100%;"> <tr> <td><input checked="" type="checkbox"/> 4 test tubes with caps</td> <td><input checked="" type="checkbox"/> test tube rack</td> <td><input checked="" type="checkbox"/> timer</td> </tr> <tr> <td><input checked="" type="checkbox"/> 2 rulers</td> <td><input checked="" type="checkbox"/> 2 droppers</td> <td><input checked="" type="checkbox"/> 2 graduated cylinders</td> </tr> </table> <p>Liquid Type:</p> <table style="width: 100%;"> <tr> <td><input type="checkbox"/> rubbing alcohol (RA)</td> <td><input type="checkbox"/> soap</td> <td><input type="checkbox"/> vinegar</td> </tr> <tr> <td colspan="3"><input checked="" type="checkbox"/> water</td> </tr> </table> <p>Liquid Amount: <u>5 mL</u> Any amount up to 20 mL (original liquid amount = 2 mL)</p> <p>Paper Type:</p> <table style="width: 100%;"> <tr> <td><input checked="" type="checkbox"/> original paper</td> <td><input type="checkbox"/> coffee filter</td> <td><input type="checkbox"/> copy paper</td> <td><input type="checkbox"/> paper towel</td> </tr> <tr> <td><input type="checkbox"/> graph paper</td> <td><input type="checkbox"/> newspaper</td> <td colspan="2"><input type="checkbox"/> construction paper</td> </tr> </table> <p>Pen Type:</p> <table style="width: 100%;"> <tr> <td><input checked="" type="checkbox"/> Mr. Sketch (original)</td> <td><input type="checkbox"/> Crayola</td> <td><input type="checkbox"/> Expo</td> </tr> <tr> <td><input type="checkbox"/> Sharpie</td> <td><input type="checkbox"/> Rose Art</td> <td><input type="checkbox"/> Bic (Black Only)</td> </tr> <tr> <td><input type="checkbox"/> Dry Erase (Black Only)</td> <td colspan="2"><input type="checkbox"/> Paper Mate (Black Only)</td> </tr> </table> <p>Pen Color:</p> <table style="width: 100%;"> <tr> <td><input type="checkbox"/> red</td> <td><input checked="" type="checkbox"/> orange <u>G</u></td> <td><input type="checkbox"/> yellow</td> <td><input type="checkbox"/> green</td> </tr> <tr> <td><input type="checkbox"/> blue</td> <td><input checked="" type="checkbox"/> purple <u>E</u></td> <td><input checked="" type="checkbox"/> black (original) <u>H</u></td> <td><input type="checkbox"/> brown</td> </tr> </table> <p>The following colors can only be chosen if your pen type is Mr. Sketch.</p> <table style="width: 100%;"> <tr> <td><input type="checkbox"/> light pink</td> <td><input type="checkbox"/> dark pink</td> <td><input type="checkbox"/> light blue</td> <td><input checked="" type="checkbox"/> light green <u>F</u></td> </tr> </table> <p>Initial Dot Height: <u>2 cm</u> Any height up to 11.5 cm (original dot height = 2 cm)</p> <p>Time: <u>4.5 min</u> Any time up to 5 minutes</p> <div style="text-align: center; border: 1px solid black; padding: 5px; width: fit-content; margin: 0 auto;">Materials Page</div>	<input checked="" type="checkbox"/> 4 test tubes with caps	<input checked="" type="checkbox"/> test tube rack	<input checked="" type="checkbox"/> timer	<input checked="" type="checkbox"/> 2 rulers	<input checked="" type="checkbox"/> 2 droppers	<input checked="" type="checkbox"/> 2 graduated cylinders	<input type="checkbox"/> rubbing alcohol (RA)	<input type="checkbox"/> soap	<input type="checkbox"/> vinegar	<input checked="" type="checkbox"/> water			<input checked="" type="checkbox"/> original paper	<input type="checkbox"/> coffee filter	<input type="checkbox"/> copy paper	<input type="checkbox"/> paper towel	<input type="checkbox"/> graph paper	<input type="checkbox"/> newspaper	<input type="checkbox"/> construction paper		<input checked="" type="checkbox"/> Mr. Sketch (original)	<input type="checkbox"/> Crayola	<input type="checkbox"/> Expo	<input type="checkbox"/> Sharpie	<input type="checkbox"/> Rose Art	<input type="checkbox"/> Bic (Black Only)	<input type="checkbox"/> Dry Erase (Black Only)	<input type="checkbox"/> Paper Mate (Black Only)		<input type="checkbox"/> red	<input checked="" type="checkbox"/> orange <u>G</u>	<input type="checkbox"/> yellow	<input type="checkbox"/> green	<input type="checkbox"/> blue	<input checked="" type="checkbox"/> purple <u>E</u>	<input checked="" type="checkbox"/> black (original) <u>H</u>	<input type="checkbox"/> brown	<input type="checkbox"/> light pink	<input type="checkbox"/> dark pink	<input type="checkbox"/> light blue	<input checked="" type="checkbox"/> light green <u>F</u>	<p>Changing Variable(s) (Independent Variable(s))</p> <p>For your second experiment, decide which variable(s) (max three) you would like to test.</p> <p>Changing Variable 1: <u>Pen Color</u></p> <p>Changing Variable 2 (optional): _____</p> <p>Changing Variable 3 (optional): _____</p> <p style="text-align: center;">QUESTION</p> <p>Question our subgroup will investigate:</p> <ul style="list-style-type: none"> • If we change the <u>pen color</u> <small>insert each changing variable (independent variable)</small>, what will happen to the <u>height and color of the smear</u> <small>insert what you are measuring/observing (dependent variable)</small>? <p style="text-align: right;">SciTrek Member Approval: <u>DF</u></p> <p style="text-align: center; font-size: small;">Get a materials page from your volunteer and fill it out before moving onto the experimental set-up.</p> <p style="text-align: right; font-size: x-small;">15</p>
<input checked="" type="checkbox"/> 4 test tubes with caps	<input checked="" type="checkbox"/> test tube rack	<input checked="" type="checkbox"/> timer																																								
<input checked="" type="checkbox"/> 2 rulers	<input checked="" type="checkbox"/> 2 droppers	<input checked="" type="checkbox"/> 2 graduated cylinders																																								
<input type="checkbox"/> rubbing alcohol (RA)	<input type="checkbox"/> soap	<input type="checkbox"/> vinegar																																								
<input checked="" type="checkbox"/> water																																										
<input checked="" type="checkbox"/> original paper	<input type="checkbox"/> coffee filter	<input type="checkbox"/> copy paper	<input type="checkbox"/> paper towel																																							
<input type="checkbox"/> graph paper	<input type="checkbox"/> newspaper	<input type="checkbox"/> construction paper																																								
<input checked="" type="checkbox"/> Mr. Sketch (original)	<input type="checkbox"/> Crayola	<input type="checkbox"/> Expo																																								
<input type="checkbox"/> Sharpie	<input type="checkbox"/> Rose Art	<input type="checkbox"/> Bic (Black Only)																																								
<input type="checkbox"/> Dry Erase (Black Only)	<input type="checkbox"/> Paper Mate (Black Only)																																									
<input type="checkbox"/> red	<input checked="" type="checkbox"/> orange <u>G</u>	<input type="checkbox"/> yellow	<input type="checkbox"/> green																																							
<input type="checkbox"/> blue	<input checked="" type="checkbox"/> purple <u>E</u>	<input checked="" type="checkbox"/> black (original) <u>H</u>	<input type="checkbox"/> brown																																							
<input type="checkbox"/> light pink	<input type="checkbox"/> dark pink	<input type="checkbox"/> light blue	<input checked="" type="checkbox"/> light green <u>F</u>																																							

Materials Page: (5 minutes – Subgroups – SciTrek Volunteers)

- Walk around and help subgroups who are struggling.
- Make sure subgroups are underlining their controls and circling their changing variable.
- Make sure subgroups are filling out the materials page correctly and completely.

Experimental Set-Up: (5 minutes – Subgroups – SciTrek Volunteers)

- Walk around and help subgroups who are struggling.

- Make sure, within one subgroup, all students have the same order for their changing variable values.
- Make sure all control blanks are filled out.

<p style="text-align: center;">PROCEDURE</p> <p>Procedure Note: Make sure to include all values of your changing variable(s) in the procedure (Ex: For a subgroup that decided to change pen color, one step would be: Put colored dot with Mr. Sketch pens E) red, F) blue, G) green, and H) yellow on original paper at 2 cm.)</p> <ol style="list-style-type: none"> 1. <u>Fill 4 test tubes with 5 mL of water.</u> _____ 2. <u>Draw dots at 2 cm on original papers with a E) purple, F) light green, G) orange, and H) black Mr. Sketch.</u> _____ 3. <u>Put papers in test tubes and put caps on.</u> _____ 4. <u>Wait for 4.5 minutes.</u> _____ 5. <u>Remove papers.</u> _____ 6. <u>Measure smear heights and observe smear colors.</u> _____ <p style="text-align: right;">SciTrek Member Approval <u>DF</u></p> <p style="text-align: right;">17</p>	<p>Changing Variable(s) (Independent Variable(s))</p> <p>For your second experiment, decide which variable(s) (max three) that you would like to test.</p> <p>Changing Variable 1: <u>Pen Color</u></p> <p>Changing Variable 2 (optional): _____</p> <p>Changing Variable 3 (optional): _____</p> <p style="text-align: center;">QUESTION</p> <p>Question our subgroup will investigate:</p> <ul style="list-style-type: none"> • If we change the <u>pen color</u>, what will happen to the <u>height and color of the smear</u>? <p style="text-align: right;">SciTrek Member Approval <u>DF</u></p> <p>Get a materials page from your SciTrek volunteer and fill it out before moving onto the experimental set-up.</p> <p style="text-align: right;">15</p>
--	---

Procedure: (11 minutes – Subgroups – SciTrek Volunteers)

- Walk around and help subgroups who are struggling.
- Make sure procedures are concise, but still include all values of the controls, and changing variable, as well as the data that will be collected.

Wrap-Up: (2 minutes – Full Class – SciTrek Lead)

- Go over what students will do next session.

Day 5: Results Table/Experiment/Graph/Conclusion

Schedule: You are responsible for **BOLD** sections

- Introduction (SciTrek Lead) – 20 minutes**
- Results Table (SciTrek Volunteers) – 5 minutes
- Experiment (SciTrek Volunteers) – 20 minutes
- Graph (SciTrek Volunteers) – 5 minutes
- Conclusion (SciTrek Volunteers) – 8 minutes
- Wrap-Up (SciTrek Lead) – 2 minutes**

Preparation:

1. Make sure volunteers are passing out notebooks.
2. Make sure volunteers are setting up for the experiment.
3. Set up the document camera for the conclusion example (notebook, page 18).

SCIENTIFIC PRACTICES
conclusions

Question: If we change the Paper height what will happen to the liquid height?

Variables	Trial A	Trial B	Trial C	Trial D
Container:	Test Tube			
Time:	5 min			
Liquid Type:	Water			
Liquid Amount:	2 ml			
Paper Type:	Original			
Pen Color:	Black			
Pen Type:	Mr. Sketch			
Initial Dot Height:	2 cm			
Paper Height:	5 cm	10 cm	15 cm	20 cm
Data	Trial A	Trial B	Trial C	Trial D
Smear Height:	3 cm	8 cm	9 cm	9 cm
Liquid Height:	5 cm	10 cm	11 cm	11 cm
Other:	blue orange red	blue orange red	blue orange red	blue orange red

Write a conclusion from the results above:

We can conclude that the liquid will reach the top of the paper if the paper is 11 cm or shorter because when the paper height was 5 cm, the liquid height was 5 cm (same as the paper height) and when the paper height was 20 cm, the liquid height was only 11 cm (not the top of the paper).

Introduction: (20 minutes – Full Class – SciTrek Lead)

- Review the class question, as well as what students did and learned last session.
- Review the definition of a conclusion (a claim supported by data).
- On the data table (notebook, page 18), have students identify and underline the controls, circle the changing variable, and box information about data collection.
- Have students identify the question the group was investigating.
- From the data, have students tell you how to draw the strips, smears, and water lines so students can visualize the experiment.

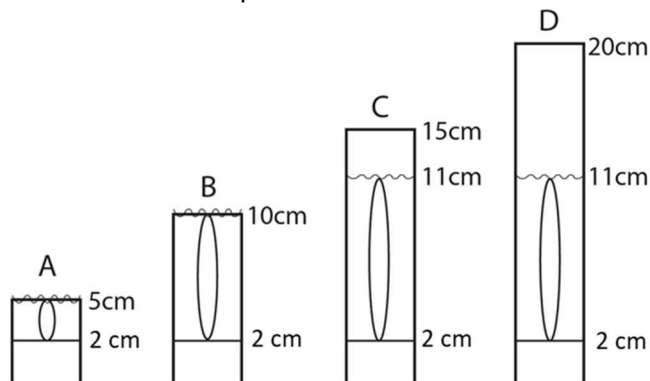

- Have students make a conclusion from the data.
 - We can conclude the liquid will reach the top of the paper if the paper is 11 cm or shorter, because when the paper height was 5 cm, the liquid height was 5 cm (same as the paper height) and when the paper height was 20 cm, the liquid height was only 11 cm (not the top of the paper).

Results Table: (5 minutes – Subgroups – SciTrek Volunteers)

- Walk around and help subgroups who are struggling.
- Make sure students are underlining controls, circling the changing variable, and boxing data collection boxes.
- Make sure control values are written in the *Trial E* box with an arrow through the rest of the trials' boxes, while changing variable values are written in each trial's box.
- Make sure students are making predictions for which trial they think will produce the shortest (S) and tallest (T) smears.

Experiment: (20 minutes – Subgroups – SciTrek Volunteers)

- Walk around and help subgroups who are struggling.
- Make sure students are labeling the test tubes with a blue wet erase pen.
- Make sure students are drawing their initial dot height line and labeling the strips with pencil.
- Make sure students are putting all the strips into the test tubes at the same time.
- Make sure volunteers are removing all of the liquids as soon as students are done with them.
- Make sure students are drawing the liquid line, with pencil, as soon as the strips come out of the test tubes.

Graph: (5 minutes – Subgroups – SciTrek Volunteers)

- Walk around and help subgroups who are struggling.
- If none of the dots smeared, students can graph the liquid height instead of smear height.
 - If students have to graph liquid height, have them go back and modify their question to be about liquid height.
- Make sure students are graphing their data from shortest smear/liquid height to longest smear/liquid height.
- Make sure students have their changing variable values (Ex: water), not the trial letters (Ex: trial F), on the x-axis.
- Make sure students are writing the numerical value of the smear/liquid height on top of each column.

Conclusion: (8 minutes – Subgroups – SciTrek Volunteers)

- Walk around and help subgroups who are struggling.
- Make sure subgroups are generating a claim (ideally the claim will allow them to make a prediction about future experiments) and using specific data points to support it.

RESULTS
Table

Fill out the chart for each of your trials. For the variables that remain constant, write the value in trial E. Then, draw an arrow through each box indicating that this variable is a control.

Variables	Trial E	Trial F	Trial G	Trial H
Container:	Test Tube	→	→	→
Time:	4.5 min	→	→	→
Liquid Type:	Water	→	→	→
Liquid Amount:	5 mL	→	→	→
Paper Type:	Original	→	→	→
Pen Color:	Purple	light green	Orange	Black
Pen Type:	Mr. Sketch	→	→	→
Initial Dot Height:	2 cm	→	→	→
Cap Placement:	On	→	→	→
Predictions	Trial E	Trial F	Trial G	Trial H
	T		S	
Data	Trial E	Trial F	Trial G	Trial H
	3	2	1	4
Measurements:				
Smear Height:	3.5 cm	3.5 cm	2.5 cm	4 cm
Liquid Height:	6 cm	5.5 cm	6 cm	6 cm
Observations:				
Other:	Purple, light purple, pink	light green, blue, yellow	Pink, orange	orange, pink, blue

Put a "T" in the trial that will give the tallest smear and an "S" in the trial that will give the shortest smear.

The independent variable(s) is(are) the changing variable(s) and the dependent variables are the final measurements/observations.

19

RESULTS
Graph

Set up your graph. (Check off the steps as you complete them.)

- Label the y-axis (vertical) with what you measured, including units (Ex: smear height (cm)).
- Determine an appropriate scale which will allow you to graph all of your data points and write the numbers on the given lines.
- Label the x-axis (horizontal) with your changing variable(s) #1, #2, and #3 (Ex: liquid type). Changing variable #2 and #3 will only be filled in if you have 2 or 3 changing variables.
- On your results table, label your measurements from 1 to 4, with 1 being the trial with the smallest measurement and 4 being the trial with the largest measurement.

Plot your data in increasing order.

- Write the changing variable value(s) (Ex: soap) for the trial that you labeled 1 under the first column.
- Graph your data for that trial and write the measurement above the bar.
- Repeat the process for the other trials.

Pen Color:	Orange	Light Green	Purple	Black
Changing Variable #1				
Changing Variable #2	:			
Changing Variable #3	:			

20

- If subgroups use observations as their data, make sure their data statement includes “we observed.”
- If subgroups use measurements as their data, make sure they are including numerical values in their data statements.
- Do not let subgroups reference trial letters in their conclusions.
- Volunteers struggle with conclusions, so you should check at least one conclusion from each group.
- If subgroups do not finish their conclusions, they can work on them during the next session.

Wrap-Up: (2 minutes – Full Class – SciTrek Lead)

- Go over what students will do next session.
- Have students attach their strips, via their nametag, to one of the notebooks in their subgroup.

Day 6: Conclusion/Poster Making

Schedule: You are responsible for **BOLD** sections

Introduction (SciTrek Lead) – 2 minutes

Conclusion (SciTrek Volunteers) – 18 minutes

Poster Making (SciTrek Volunteers) – 35 minutes

Wrap-Up (SciTrek Lead) – 5 minutes

Preparation:

1. Make sure volunteers are setting out notebooks.
2. Find a place to leave student posters.

Introduction: (2 minutes – Full Class – SciTrek Lead)

- Review the class question, what students did and learned last session, as well as what they will do today.

Conclusion: (18 minutes – Full Class – SciTrek Volunteers)

- Walk around and help subgroups who are struggling.
- Make sure subgroups are generating a claim (ideally the claim will allow them to make a prediction about future experiments) and use two specific data points to support it.
 - If subgroups use an observation as data, make sure their data statement includes “we observed.”
 - If subgroups use measurements as their data, make sure they are including numerical values in their data statements.
 - Do not let subgroups reference trial letters in their conclusion.
- Volunteers struggle with conclusions, so you should check at least one conclusion from each group.
- Make sure students fill out the sentence frame (notebook, page 21, bottom) *I acted like a scientist when.*

CONCLUSION	
<p>Generate a claim about how your changing variable affected your results. (Ex: the shorter the paper the shorter the smear height.)</p>	<p>We can conclude <u>that the pen color does not greatly affect the smear height, but does affect the color of the smear</u></p>
<p>What data do you have to support your claim? (Remember to include your measurements and/or observations, <u>not trail letters.</u>)</p>	<p>because <u>the smear height for the light green and purple pens were 3.5 cm, but we observed the smears for the light green pen contained light green, blue, and yellow while the smear for the purple pen contained purple, light purple and pink</u></p>
<p>Can you test the first part (claim) of the conclusion?</p> <p style="text-align: center;"> <input checked="" type="checkbox"/> YES <input type="checkbox"/> NO (If you checked this box go back and revise your claim so that it can be.) </p>	
<p>The second part of the conclusion is data because it contains a <u>measurement</u></p>	
<p>I acted like a scientist when <u>I observed the colors of the smears and measured the smear heights.</u></p>	

Poster Making: (35 minutes – Subgroups – SciTrek Volunteers)

- Help volunteers glue poster pieces onto the posters. When gluing, make sure **you** or the **volunteers** (not the students) are gluing the poster in the exact order that is shown on the diagram and the poster has a landscape orientation.
 - **Do not let the volunteers forget to glue the strips onto the poster.**
- Make sure the student in each subgroup who is presenting the results graph, has a sentence frame sticker in their notebook and a volunteer has gone over how to present the four sentences with the student several times.
- Each student should have the part(s) they are presenting highlighted and numbered, in their notebook: 1) scientists' names, 2) question, 3) experimental set-up, 4) procedure, 5) results graph, and 6) conclusion (see pictures below).
 - Remind volunteers if a student is presenting multiple parts, they should have multiple sections highlighted and numbered in their notebook and the sections should be paperclipped together.
- Volunteers often forget to highlight notebooks, so make sure this gets done before Day 7.

A larger version of this poster is in your lead box.

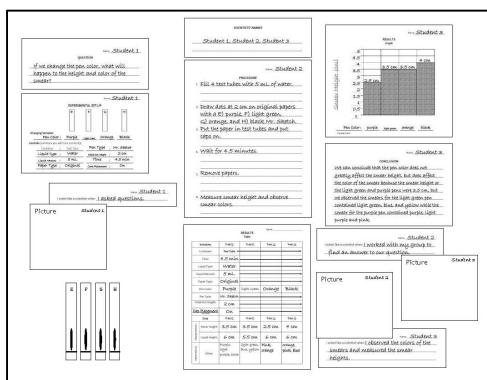

Changing Variable(s) (Independent Variable(s))
 For your second experiment, decide which variable(s) (max three) that you would like to test.

Changing Variable 1: Pen Color

Changing Variable 2 (optional): _____

Changing Variable 3 (optional): _____

#1 The scientists in our group are _____

#2 QUESTION
 Question our subgroup will investigate:
 • If we change the pen color what will happen to the height and color of the smear?

SciTrek Member Approval: DF

Get a materials page from your SciTrek volunteer and fill it out before moving onto the experimental set-up.

#3 EXPERIMENTAL SET-UP
 Write your changing variable(s) (Ex: pen color) and the values (Ex: blue) you will use for your trials under each strip of paper.

E	F	G	H
---	---	---	---

Changing Variable(s):
 1) Pen Color: Purple, Light green, Orange, Black

2) _____

3) _____

Controls (variables you will hold constant):
 Write the controls and the values you will use in all your trials (control values, Ex: container/test tube).

Container /	Test Tube	Pen Type /	Mr. Sketch
Liquid Type /	Water	Water pen height /	2 cm
Liquid Amount /	5 mL	Time /	4.5 min
Paper Type /	Original	Cap Placement /	On

SciTrek Member Approval: DF

#4 PROCEDURE

Procedure Note:
 Make sure to include all values of your changing variable(s) in the procedure (Ex: For a subgroup that decided to change pen color, one step would be: Put colored dot with Mr. Sketch pens (1) red, (2) blue, (3) green, and (4) yellow on original paper at 2 cm.)

1. Fill 4 test tubes with 5 mL of water.
2. Draw dots at 2 cm on original papers with a E) purple, F) light green, G) orange, and H) black Mr. Sketch.
3. Put papers in test tubes and put caps on.
4. Wait for 4.5 minutes.
5. Remove papers.
6. Measure smear heights and observe smear colors.

SciTrek Member Approval: DF

#5 RESULTS Graph

Set up your graph. (Check off the steps as you complete them.)

- 1) Label the y-axis (vertical) with what you measured, including units (Ex: smear height (cm)).
- 2) Determine an appropriate scale which will allow you to graph all of your data points and write the numbers on the given lines.
- 3) Label the x-axis (horizontal) with your changing variable(s) P₁, P₂, and P₃ (Ex: liquid type). Changing variable P₁ and P₂ will only be filled in if you have 2 or 3 changing variables.
- 4) On your results table, label your measurements from 1 to 4, with 1 being the trial with the smallest measurement and 4 being the trial with the largest measurement.

Plot your data in increasing order.

- 1) Write the changing variable value(s) (Ex: soap) for the trial that you labeled 1 under the first column.
- 2) Graph your data for that trial and write the measurement above the bar.
- 3) Repeat the process for the other trials.

Pen Color: Orange Light green Purple Black

The Smear height for _____ was _____

SciTrek Member Approval: _____

#6 CONCLUSION

Generate a claim about how your changing variable affected your results. (Ex: the shorter the paper the shorter the smear height.)

What data do you have to support your claim? (Remember to include your measurements and/or observations, not trail letters.)

We can conclude that the pen color does not greatly affect the smear height, but does affect the color of the smear

because the smear height for the light green and purple pens were 3.5 cm, but we observed the smears for the light green pen contained light green, blue, and yellow while the smear for the purple pen contained purple, light purple and pink

Can you test the first part (claim) of the conclusion?
 YES NO (If you checked this box go back and revise your claim so that it can be.)

The second part of the conclusion is data because it contains a measurement

I acted like a scientist when I observed the colors of the smears and measured the smear heights.

Wrap-Up: (5 minutes – Full Class – SciTrek Lead)

- Ask students the following questions:
 - How did you act like a scientist during this project?
 - What did you do, that scientists do?

Day 7: Poster Presentations

Schedule: You are responsible for **BOLD** sections

Introduction (SciTrek Lead) – 2 minutes

Practice Posters (SciTrek Volunteers) – 5 minutes

Poster Presentations (SciTrek Volunteers/SciTrek Lead) – 51 minutes

Wrap-Up (SciTrek Lead) – 2 minutes

Preparation:

1. Make sure volunteers are passing out notebooks.
2. Set up the document camera for the *Notes on Presentations* (picture packet, pages 3 and 4).
3. Organize posters so experiments featuring the same changing variable will be presented back-to-back and posters are presented from simplest to understand, to most difficult to understand (suggested order: time, paper type, liquid type, dot height, liquid amount, pen type, and pen color).

Introduction: (2 minutes – Full Class – SciTrek Lead)

- Review the class question, as well as what students did and learned last session.

Practice Posters: (5 minutes – Subgroups – SciTrek Volunteers)

- **Do not give students more than 5 minutes to practice or you will run out of time for presentations.**
- Make sure students are reading from their notebooks and practicing the posters in the following order: 1) scientists' names, 2) question, 3) experimental set-up, 4) procedure, 5) results graph, and 6) conclusion. They will **not** read the *I acted like a scientist when* or results tables from their posters.

Poster Presentations: (51 minutes – Full Class – SciTrek Volunteers/SciTrek Lead)

- Have students present their posters.
- While posters are being presented, record each subgroup's changing variable values, and their data (picture packet, pages 3 and 4) while students do the same (notebook, pages 22 and 23).
 - After a subgroup reads their question, stop the presentation and have the class identify the changing variable. Then, record it in the picture packet while students do the same in their notebook. If needed, change smear height to liquid height.
 - When a subgroup reads their results graph, record the values of the changing variable and their measurements.
- After each presentation, ask students:
 - What questions do you have for this subgroup?
- Once students have asked their questions (make sure each student answers a question; you should ask at least one question per presentation), have students summarize what they learned and record it (picture packet, pages 3 and 4); while students do the same (notebook, pages 22 and 23).
 - If students are unable to do this, encourage them to ask more questions.
- Students will not record information about their own subgroup's poster presentation.
- After all presentations are over, have students tell you the variable values they would select to cause the longest smear.

NOTES ON PRESENTATIONS
What variables affect smears?

Subgroup 1

Changing Variable: Time (min)	1	2	3	5
Smear Height (cm):	0.5	5	7.5	10

Summary: A longer time results in a taller smear.

Subgroup 2

Changing Variable: Paper Type	graph	news	paper towel	coffee filter
Smear Height (cm): Liquid Height	2	2.5	8	9

Summary: Sharpie does not smear in water.

Subgroup 3

Changing Variable: Paper Type	Construction	news	original	paper towel
Smear Height (cm):	0	0.5	4	8

Summary: More absorbent papers make taller smears.

Subgroup 4

Changing Variable: Liquid Type	soap	RA	vinegar	water
Smear Height (cm):	0.5	3	4	6

Summary: Thicker liquids result in shorter smears.

Picture Packet, Page 3

3

Subgroup 5

Changing Variable: Liquid Type	soap	vinegar	RA	Water
Smear Height (cm):	1	3	4	6

Summary: Agrees with previous subgroup.

Subgroup 6

Changing Variable: initial dot Height (cm)	1	2	4	3
Smear Height (cm):	1, down	2, down	5, up	6, up

Summary: If the liquid is above the dot, the smear goes down.

Subgroup 7

Changing Variable: Liquid Amount (mL)	10	20	1	5
Smear Height (cm):	2, down	2, down	3, up	7, up

Summary: When the liquid is just below the dot, it smears up the highest.

Subgroup 8

Changing Variable: Liquid Amount (mL)	Sharpie	Crayola	Mr. Sketch	Expo
Smear Height (cm):	0	7.5	7.5	8

Summary: Washable markers make smears and permanent markers do not.

Subgroup 9

Changing Variable: Pen Color	Orange	Light Green	Purple	Black
Smear Height (cm):	2.5	3.5	3.5	4

Summary: Pen color affect smear color more than smear height.

Picture Packet, Page 4

4

Wrap-Up: (2 minutes – Full Class – SciTrek Lead)

- Tell students, “The mentors who have been working with you are undergraduate and graduate students, who volunteer their time so you can do experiments. This is the last day you will see your volunteers, so we should say thank you and goodbye.”
- Have students remove the paper parts of their nametags (which they can keep) from the plastic holders, and return the plastic holders to their volunteers.

Day 8: Draw a Scientist/Tie to Standards/Content Assessment

Note: We **highly recommend** teachers give the conclusion assessment prior to Day 8 of the module. The suggested times in the lesson plan below are assuming students completed the conclusion assessment prior to SciTrek’s arrival.

Schedule: You are responsible for **BOLD** sections

Times if teacher gave assessment prior to SciTrek:

- Draw a Scientist (SciTrek Lead) – 5 minutes**
- Tie to Standards (SciTrek Lead) – 45 minutes**
- Content Assessment (SciTrek Lead) – 10 minutes**

Times if SciTrek must give assessment:

- Conclusion Assessment (SciTrek Lead) – 10 minutes**
- Draw a Scientist (SciTrek Lead) – 5 minutes**
- Tie to Standards (SciTrek Lead) – 35 minutes**
- Content Assessment (SciTrek Lead) – 10 minutes**

Preparation:

1. Get the conclusion assessments and put them in the lead box.
2. If the teacher is not leading the tie to standards activity, do the following:
 - a. Ask the teacher if they completed the SciTrek final survey. If not, give them the QR code from the lead box and ask them to go to the website (at a later time) and fill out the evaluation of the program.
 - b. Give the teacher an extra notebook and have them fill it out with their students, to follow along during the tie to standards activity.
 - c. Collect the teacher's lab coat, and put it in the lead box.
3. If you are a teacher and have not completed the SciTrek final survey, take the QR code from the lead box and fill out the evaluation of the program, at a later time.
4. Pass out notebooks.
5. Set up the document camera for the tie to standards activity (notebook, pages 24-26; picture packet, pages 1, 5, and 6).
6. Tape the *Matter Chart* to the board.
7. Have mixture and pure substances available for use during the tie to standards activity.
8. Put your lab coat in the lead box at the end of the day.

Conclusion Assessment: (10 minutes – Full Class – Given By Classroom Teacher Prior to SciTrek)

- Page 1 (top): Read the two questions aloud, and have students fill them in.
- Page 1 (bottom): Read each statement and have students circle whether the statement is a claim, data, or opinion.
- Page 2 (top): Have students underline controls, circle changing variable(s), and box information about data collection on the results table. Then, have students decide if the group could make a conclusion.
- Page 2 (bottom): Read each statement and have students identify if the statement is a claim or data and then circle if statement is a correct claim, correct data, or incorrect based on the results table.
- Page 3: Repeat the process for page 3.
- Page 4: Read the instruction then have students use the results table to write a conclusion.
- Page 5: Have students select if each of the scenario's would allow a student to answer their question.
- Page 6: Have students select values of variable for each trial that would allow them to answer the question. Then, have students write why they selected these values.
- Collect assessments.

Draw a Scientist: (5 minutes – Full Class – SciTrek Lead)

- Pass out the Draw a Scientist page.
- Give students exactly 4 minutes to draw a picture of a scientist.
- If the students drew a specific person, have them write who they drew on the line at the bottom of the page. Have them leave it blank if it is just a general person/picture.
- Collect assessments.

Tie to Standards: (45 minutes – Full Class – SciTrek Lead)

Mysterious Robbery (12 minutes)

- Tell students, “10 years ago a robbery happened that was never solved. The police have contacted you to solve the cold case. At the time of the crime, a note written in black pen was passed to the teller which read ‘Give me all your money.’ The teller handed over the money but kept the note. In the confusion that followed, the robber managed to get away. At the time there were eight suspects. Each of these suspects was found with a black pen on them (which the police still have). The only other evidence the police have from the original crime is the note.”
 - If asked, tell students, “No fingerprints or DNA were found.”
- Have students determine how they could help the police solve the crime.
 - If they took all the pens, they could determine what colors the black pens separate into and match it to the colors the pen on the note separated into.
- Ask students, “Would it be easier to identify the robber’s pen if they had a tall or short smear?” Students should reply, “Tall smear.”
- Have students help you decide which values of the variables they should tell the police to use to produce the tallest smear for question 1 (notebook, page 24).
 - Time: 10 minutes
 - Liquid type: Water
 - Liquid amount: Liquid level just below the dot
- Tell students, “I gave the police your suggested values and they ran the test.” Show them the data (picture packet, page 5).
- Have students identify the robber and then write a conclusion about their findings for question 2. Make sure the data statement contains “we observed.”

TIE TO STANDARDS

1. Circle the value of the variable that the police should use to process the evidence from the suspects that would give them the tallest smear.

Time: 3 min 5 min 10 min All would give similar height smears

Liquid Type: Water Soap Syrup All would give similar height smears

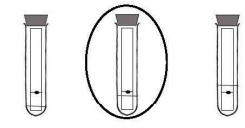
Amount of Liquid/Line Level:  All would give similar height smears

2. What conclusion can you make from the results the police collected?

We can conclude that the robber was number four claim because it was observed that the ink from the robber and number four were the same height and color. data

3. What did we learn about black ink? It is a mixture

24

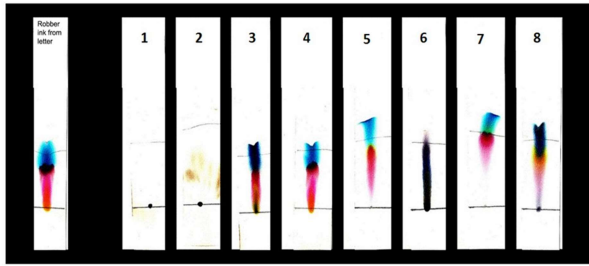

Picture Packet, Page 5

5

Mixture Discussion (10 minutes)

- Ask students, “What did you learn about black ink?” Students should reply, “Black ink is a mixture.” Fill in question 3.
- Go over the definition of matter with students and have them tell you if several objects around the room are matter. Then, tell them that things like dreams, ideas, and energy are not matter.
 - Write in “matter” in the top box in the chart on question 4.
- Ask students, “Is black ink matter?”

- Go over the definition of a mixture and review mixtures.
 - Write in 'mixture' in the bottom left box of the chart for question 4.
 - Give the example mixture of Lucky Charms and have students identify the parts of the mixture.
 - Have students come up with at least one other mixture that can be distinguished by eye and record it and its parts on the *Matter Chart*.
 - Tell students, "Sometimes you cannot see the individual parts of a mixture. Such as with black ink or air." Have students give you the parts of the mixture for air and record them on the *Matter Chart*.
 - Have students come up with at least one other mixture that cannot be distinguished by eye, and record it and its parts on the *Matter Chart*.

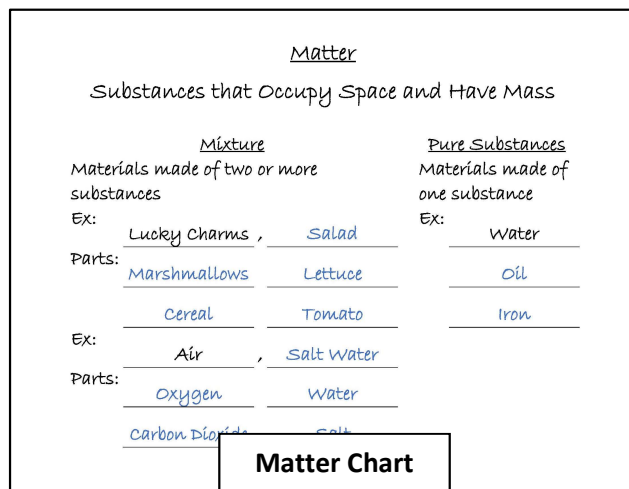

- Tell students, "Mixtures can be separated into pure substances." Review the definition of a pure substance with the students from the *Matter Chart*.
 - Write in "pure substance" in the bottom right box of the chart for question 4.
 - Give the example of water. Have students come up with two more pure substances and record them on the *Matter Chart*.
- Tell students, "Mixtures can be separated into pure substances by using differences in the physical properties of the parts of the mixture."
 - Write in "physical property" on the line under *matter* on the chart for question 4.
- Tell students, "A physical property is a property that can be measured or observed without changing the substance." Then, have students fill in the definition for question 5.
- Ask students, "What physical properties could you use to separate the Lucky Charms?" Record these properties under 'physical properties' on question 4.

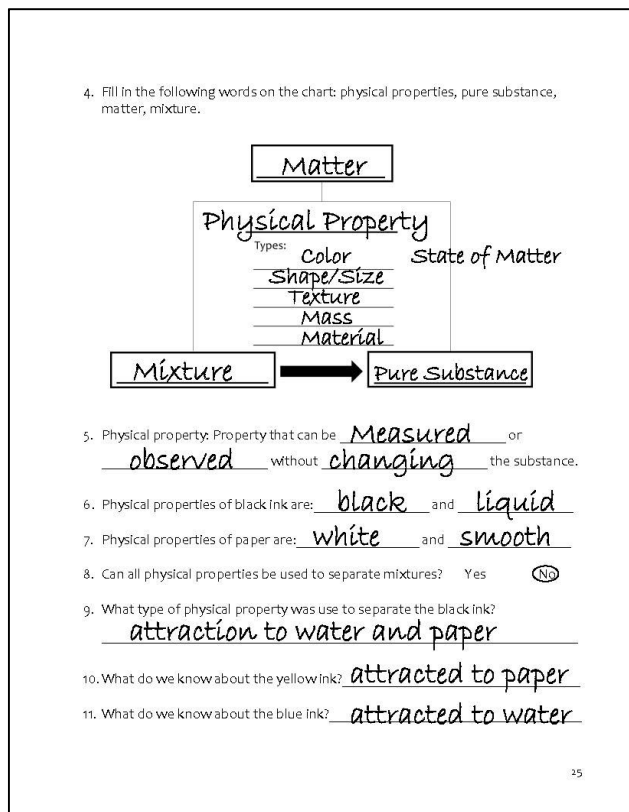

- Make sure students record the physical property (Ex: color) and not the values of the property (Ex: red, blue, etc.)
- If the blanks are not all filled, it is okay. You can add more physical properties as you go.
- Have students identify physical properties of the black ink and paper, and record these values in question 6 and 7.
 - If students come up with a physical property that is not on the list, add it to the list in question 4.
 - If you run out of room write, the additional properties in the margins.
- Ask students the following questions:
 - Is black ink a mixture or a pure substance? (mixture)
 - Were we able to separate the black ink into parts? (yes)
- Ask students, "Can all physical properties be used to separate mixtures? For instance, if we know the ink is made up of red and blue dyes, would that help us separate the mixture?" Students should reply, "No." Fill in question 8.

- Ask students the following questions:
 - How were we able to separate out the different dye colors? (put the strips in liquids)
 - Why did some colors travel farther up the paper than others? (some dyes are attracted to water more than the paper and were carried up the strip farther)
- Tell students, “The physical property we used to separate the blank ink was the ‘attraction to water’ and ‘attraction to paper.’”
- Show students the example strip from Day 1 (picture packet, page 1) and have them answer questions 10 and 11.

Separating Mixtures/Physical Properties (7 minutes)

- Show students the jar of water and sand (Tie to Standards box) and have them determine the following:
 - Physical properties of each component of the mixture (Ex: liquid and solid).
 - If the physical property they identified would be useful in separating the mixture.
 - If water and sand are pure substances.
- Record any new types of physical properties students come up in question 4.

Pure Substances (16 minutes)

- Tell students, “Physical properties can also be used to identify pure substances,” and have students fill out question 13.
- Pass out the labeled pure substances.
- Have students write down the physical properties of each of the pure substances.
- Collect labeled pure substances and pass out lettered pure substances.
- Have students identify the lettered pure substances.

Content Assessment: (10 minutes – Full Class – SciTrek Lead)

- Pass out content assessments.
- Read each question to students.
- Collect content assessments.

12. Determine how you would separate each mixture into two parts.

Mixture	List 3 Physical Properties of each part of the mixture		Helpful in Separating (circle one)	
	Water	Sand		
	Liquid	Solid	Yes	No
	Clear	Brown	Yes	No
	light	Heavy	Yes	No

Is water a pure substance? Yes No

Is sand a pure substance? Yes No

13. Physical properties can be used to separate mixtures and identify pure substances.

14. Write down physical properties of the four substances. You will use these to identify four unknown substances. You will not have access to the labeled substances when you are identifying the unknown substances.

Pure Substance	Physical Properties	Unknown Letter
Sugar	Brown, small granules, many different shaped pieces	B
Salt	White, small granules, square shaped pieces	C
Baking Soda	White powder	A
Corn Starch	White powder, sticks to sides of bag, crunches when pinched	D

26

Extra Practice Solutions:
EXTRA PRACTICE
Conclusions

Directions: On the results table, underline each control, circle each changing variable(s), and box information about data collection.

Variables		Trial A	Trial B
Time:		5 min	5 min
Liquid Type:		Water	Soap
Liquid Amount:		2 ml	2 ml
Paper Type:		Original	Original
Pen Color:		Red	Red
Pen Type:		Mr. Sketch	Mr. Sketch
Data		Trial A	Trial B
Smear Height:		4 cm	0.5 cm
Liquid Height:		6 cm	3 cm
Other:		Green Blue Red	Pink Orange

Can this group make a claim/conclusion? Yes No I Don't Know

- Step 1: Statement Type: C or D
- Step 2: Based on the table, is the statement a correct claim, correct data, or incorrect?
- the height of the smear in water was 4 cm and the height of the smear in soap was 0.5 cm **D** Correct Claim **Correct Data** Incorrect
 - the type of liquid does not affect the smear height **C** Correct Claim **Correct Data** **Incorrect**
 - with 2 ml of liquid, the thicker liquid results in a shorter smear height **C** **Correct Claim** **Correct Data** Incorrect
 - the color of the pen affects the smear height **C** Correct Claim **Correct Data** **Incorrect**
 - the liquid type affects the smear height **C** **Correct Claim** **Correct Data** Incorrect

What data can be used to support the correct claim(s) above? The thicker liquid (soap) had a 0.5 cm high smear and the thinner liquid (water) had a 4 cm high smear.