

Module 2: Chromatography

5th Grade

About the Instructions:

This document is intended for use by classroom teachers, SciTrek leads, and SciTrek volunteers. The document has been composed with input from teachers, leads, volunteers, and SciTrek staff to provide suggestions for future teachers/leads/volunteers. The instructions are not intended to be used as a direct script, but were written to provide teachers/leads/volunteers with a guideline to present the information that has worked in the past. Teachers/leads/volunteers should feel free to deviate from the instructions to help students reach the learning objectives of the module. Places in which you can be creative and mold the program to meet your individual teaching style, or to meet the needs of students in the class are: during class discussions, managing the groups/class, generating alternative examples, and asking students leading questions. However, while running the module make sure to cover all the material each day within the scheduled 60 minutes. In addition, no changes should be made to the academic language surrounding conclusions or the conclusion activity.

Activity Schedule:

There are no scheduling restrictions for this module.

Day 1: Conclusion Assessment/Observations/Variables (60 minutes)

Day 2: Question/Materials Page/Experimental Set-Up/Procedure (60 minutes)

Day 3: Results Table/Experiment/Graph/Conclusion Activity (60 minutes)

Day 4: Conclusion Activity/Conclusion/Question/Materials Page/Experimental Set-Up/Procedure (60 minutes)

Day 5: Results Table/Experiment/Graph/Conclusion (60 minutes)

Day 6: Conclusion/Poster Making (60 minutes)

Day 7: Poster Presentations (60 minutes)

Day 8: Draw a Scientist/Tie to Standards/Content Assessment (60 minutes)

*This schedule assumes the teacher has given the conclusion assessment before SciTrek comes on Day 8 of the module.

The exact module dates and times are posted on the SciTrek website (scitrek.chem.ucsb.edu/elementary) under the school/teacher. The times on the website include transportation time to and from outside of Chem 1204. Thirty minutes are allotted for transportation before and after the module. Therefore, if a module was running from 10:00-11:00, then the module times on the website would be from 9:30-11:30.

Student Groups:

For the initial observation (Day 1), students work in three groups of approximately ten students each. After Day 1, the groups of approximately ten students are further subdivided into three subgroups, approximately four students each, for the rest of the module. One volunteer is assigned to help each group (which is made up of three subgroups). We find groups/subgroups work best when they are mixed levels and mixed language abilities.

NGSS Performance Expectation Addressed:

5-PS1-3 Make observations and measurements to identify materials based on their properties.

Learning Objectives:

1. Students will be able to list at least one physical property of a substance.
2. Students will know mixtures can be separated based on the physical properties of individual substances in the mixture.
3. Students will know a conclusion is a claim supported by data.
4. Students will be able to classify a statement as claim, data, or opinion.
5. Students will be able to identify appropriate claims and data for a given data set.
6. Students will know they must only have one changing variable in order to draw a conclusion.
7. Students, in small groups, will be able to select a question and make experiment decision that allows them to answer their question and present their findings to the class.
8. Students will be able to list at least two ways they behaved like scientists.

Classroom Teacher Responsibilities:

In order for SciTrek to be sustainable, the program needs to work with teachers on developing their abilities to run student-centered, inquiry-based science lessons on their own in their classrooms. As teachers take over the role of SciTrek lead, SciTrek will expand to additional classrooms. Even when teachers lead the modules in their own classrooms, SciTrek will continue to provide volunteers, and all of the materials needed to run the module. Below is a sample timeline for teachers to take over the role as the SciTrek lead.

*Groups are made up of approximately ten students and are subdivided into three subgroups (approximately four students each) after Day 1 of the module.

1. Year 1
 - a. Classroom teacher leads a group (Role: Group Lead; this is referred to as a volunteer in these instructions)
2. Year 2
 - a. Classroom teacher co-leads the modules with a SciTrek staff member (Role: Co-Lead)
 - i. Classroom teacher will be responsible for leading entire class discussions (Ex: conclusion activity).
 - ii. Classroom teacher will be responsible for time management.
 - iii. Classroom teacher will be responsible for overseeing volunteers and helping any groups who are struggling.
 - iv. Classroom teacher will be responsible for all above activities. The SciTrek co-lead will only step in for emergencies.
 - v. The SciTrek co-lead will run the tie to standards activity.
3. Year 3 and beyond
 - a. Classroom teacher leads the modules (Role: Lead)
 - i. Classroom teacher will be responsible for leading entire class discussions (Ex: conclusion activity).
 - ii. Classroom teacher will be responsible for time management.
 - iii. Classroom teacher will be responsible for overseeing volunteers and helping any groups who are struggling.
 - iv. For year 3 a SciTrek staff member will co-lead the tie to standards activity with the classroom teacher, for subsequent years they will run the tie to standards independently.

SciTrek staff is counting on teacher involvement. Teachers should notify the SciTrek staff if they will not be present on any day(s) of the module. Additional steps can be taken to become a SciTrek lead faster than the proposed schedule above. Contact scitrekelementary@chem.ucsb.edu to learn more.

In addition, teachers are required to come to UCSB for the module orientation, approximately one week prior to the start of the module. Contact scitrekelementary@chem.ucsb.edu for exact times and dates, or see our website at scitrek.chem.ucsb.edu/elementary under your class's module times. At the orientation, teachers will go over module content, learn their responsibilities during the module, and meet the volunteers who will be helping in their classroom. Failure to come to the module orientation might result in loss of priority registration for the following year.

Prior to the Module (at least 1 week):

1. Come to the SciTrek module orientation at UCSB.

Notes for Teachers During the Module:

Note: We **highly recommend** you give the final conclusion assessment prior to **Day 8** of the module.

If possible, have a document camera available to the SciTrek lead every day of the module. If you do not have a document camera, please tell a SciTrek staff member at orientation.

Day 1:

Have students' desks/tables moved into three groups and cleared off.

Day 2 - 6:

Have students' desks/tables moved into nine groups and cleared off.

Day 7 - 8:

Have students' desks/tables cleared off. The desks/tables do not need to be moved into groups.

Scheduling Alternatives:

Some teachers have expressed interest in giving the students more time to work with the volunteers throughout the module. Below are options that will allow the students more time to work with the volunteers. If you plan to do any of the following options, please inform the SciTrek staff no later than your orientation date (approximately one week before your module, exact orientation times are found at: scitrek.chem.ucsb.edu/elementary). This will allow the SciTrek staff to provide you with all needed materials.

Day 1:

If you would like to have more time for your students to make observations and generate variables, you can give the conclusion assessment to your class, **before** SciTrek arrives.

Day 2:

If you would like to have more time for your students to design their experiments, you can do the example question/experimental set-up, outlined in the Introduction with your class, **before** SciTrek arrives.

Day 3:

If you would like to have more time for your students to perform their experiments, you can do one or both of the following activities with your class:

- 1) Example graph outlined in the Introduction, **before** SciTrek arrives.
- 2) Conclusion activity, **after** SciTrek leaves.

Day 4:

If you would like to have more time for your students to redesign their experiments, you can finish the conclusion activity with your class, **before** SciTrek arrives.

Day 5:

If you would like to have more time for your students to perform their experiments and write conclusions, you can do the example conclusion with your class, **before** SciTrek arrives.

Day 7:

If you would like to have more time for your students to discuss their experiments during poster presentations, you may take more time for each presentation and finish the presentations with your class, **after** SciTrek leaves.

Day 8:

If you would like more time for the tie to standards activity, you may give the conclusion assessment to your class, **before** SciTrek arrives. **(highly recommended)**

Materials Used for this Module:

1. Crayola crayons, 8 count
2. Large plastic test tubes with caps (baby soda bottles) (Steve Spangler Science)
3. Large plastic test tubes rack (Steve Spangler Science)
4. Nalgene graduated cylinders 10 mL (Fisher Part Number: 08-572-5A)
5. Chromatography paper (roll 2 cm x 100 m (thickness 0.18mm) cut into 11.5 cm strips) (Fisher Part Number: S47087)
6. Other papers (all papers are cut into 2 cm x 11.5 cm strips)
Papers (coffee filter, construction paper, graph paper, newspaper, paper towel, and copy paper)
7. Rulers (Office Depot Part Number: 21215472)
8. MyChron Timers (Fisher Part Number: S65330)
9. Disposable pipets (droppers) (Fisher Part Number: 13-711-7M)
10. Markers
Mr. Sketch (red, orange, yellow light green, dark green, light blue, dark blue, purple, light pink, dark pink, black, and brown)
Crayola (red, yellow, green, blue, purple, black, and brown)
Expo-Overhead pens (red, yellow, green, blue, purple, black, and brown)
Sharpie (red, yellow, green, blue, purple, black, and brown)
Rose Art (red, yellow, green, blue, purple, black, and brown)
Other Black Pens (Bic, Dry Erase, and Paper Mate)
11. Water
12. Rubbing alcohol (RA)
13. White vinegar
14. Dish soap (without dilution, the dish soap is too thick to be absorbed by the paper, therefore, a soap solution is made by mixing equal parts of water and dish soap)
15. 4 oz. Natural polyethylene wide mouth oblong bottle with 38/400 cap with F217 liner (United States Plastic Corp: 66557)
16. 1 oz. Plastic cups (Smart and Final) labeled: water, RA, soap, and vinegar
17. Bags with 2 oz. of the following: baking soda, corn starch, salt, and sugar (both labeled with their names and A, B, C, and D) (Uline Part Number: S485)
18. Bottle containing sand and water

All printed materials used by SciTrek (notebooks, materials page, picture packet, poster parts, instructions, and nametags) can be made available for use and/or editing by emailing scitrekelementary@chem.ucsb.edu.

Types of Documents:**Notebook:**

One given to every student and is filled out by the student. The lead will use a notebook to write in as an example for students. The notebook the lead uses is referred to as the class notebook in these instructions.

Notepad:

One given to every group and is filled out by the volunteer. In these instructions, the examples are narrower and taller than the notebook pages.

Picture Packet:

One per class that, if needed, the lead fills out. In these instructions, the examples are the same size as the notebook pages, but they are labeled.

In these instructions, all other example documents are labeled.

Day 1: Conclusion Assessment/Observations/Variables**Schedule:**

Introduction (SciTrek Lead) – 2 minutes
Conclusion Assessment (SciTrek Lead) – 10 minutes
Observation Discussion (SciTrek Lead) – 2 minutes
Observations (SciTrek Volunteers) – 26 minutes
Variable Discussion (SciTrek Lead) – 5 minutes
Variables (SciTrek Volunteers) – 12 minutes
Wrap-Up (SciTrek Lead) – 3 minutes

Materials:**(3) Volunteer Boxes:**

- | | | |
|---|--|--|
| <input type="checkbox"/> Nametags | <input type="checkbox"/> (2) Dry erase markers | <input type="checkbox"/> Test tube stand |
| <input type="checkbox"/> (NS+1) Notebooks | <input type="checkbox"/> (2) Rulers | <input type="checkbox"/> 10 mL graduated cylinder |
| <input type="checkbox"/> Volunteer instructions | <input type="checkbox"/> Paper towels | <input type="checkbox"/> (2) Pieces of chromatography paper with pencil line drawn 2 cm above bottom |
| <input type="checkbox"/> Picture of experimental set-up | <input type="checkbox"/> Timer | <input type="checkbox"/> Black marker (Mr. Sketch) |
| <input type="checkbox"/> Volunteer lab coat | <input type="checkbox"/> Water (8 oz) | <input type="checkbox"/> (5) Boxes of crayons (8 colors) |
| <input type="checkbox"/> (2) Pencils | <input type="checkbox"/> Dropper | |
| | <input type="checkbox"/> Test tube with cap | |

Other Supplies:

- | | |
|---------------------------------------|------------------------------------|
| <input type="checkbox"/> (3) Notepads | <input type="checkbox"/> (3) Trays |
|---------------------------------------|------------------------------------|

Lead Box:

- | | | |
|---|--|--|
| <input type="checkbox"/> (3) Blank nametags | <input type="checkbox"/> (2) Pencils | <input type="checkbox"/> (2) Test tubes with caps |
| <input type="checkbox"/> (3) Extra notebooks | <input type="checkbox"/> (2) Wet erase markers | <input type="checkbox"/> (2) Test tube stands |
| <input type="checkbox"/> Lead instructions | <input type="checkbox"/> (2) Black pens | <input type="checkbox"/> (2) 10 mL graduated cylinders |
| <input type="checkbox"/> Chromatography picture packet | <input type="checkbox"/> (3) Markers (orange, blue, green) | <input type="checkbox"/> (4) Pieces of chromatography paper with pencil line drawn 2 cm above bottom |
| <input type="checkbox"/> Picture of experimental set-up | <input type="checkbox"/> (2) Rulers | <input type="checkbox"/> (2) Black markers (Mr. Sketch) |
| <input type="checkbox"/> Lead lab coat | <input type="checkbox"/> Paper towels | <input type="checkbox"/> (5) Boxes of crayons (8 colors) |
| <input type="checkbox"/> (35) Conclusion assessments | <input type="checkbox"/> (2) Timers | |
| <input type="checkbox"/> Time card | <input type="checkbox"/> Water (8 oz) | |
| | <input type="checkbox"/> (2) Droppers | |

Notepad and Notebook Pages:

OBSERVATIONS

Experimental Set-Up: Black Mr. Sketch pen
graduated cylinder with 2 mL of water
paper 11.5 cm high with line on it at 2 cm
timer
5 boxes of crayons
test tube and test tube holder

	Time 0	Time 1	Time 2
Time:	0 s	3 min 20 s	7 min 10 s
Picture:			
Measurements/ Observations:	<ul style="list-style-type: none"> • Small black dot on line (2cm) • Strip put into test tube with water 	<ul style="list-style-type: none"> • Dot turned into smear • Black turned into blue and red 	<ul style="list-style-type: none"> • Smear got longer (3.0 cm) • Water went up paper (5.0 cm) • Blue, pink, red and orange all seen

2

OBSERVATIONS

Experimental Set-Up: Black Mr. Sketch pen
Graduated cylinder with 2 mL of water
Paper 11.5 cm high with line on it at 2 cm
Timer
5 boxes of crayons
Test tube and test tube holder

	Time 0	Time 1	Time 2
Time:	0 s	3 min 20 s	7 min 10 s
Picture:			
Measurements/ Observations:	<ul style="list-style-type: none"> • Small black dot on line (2 cm) • Strip put into test tube with water 	<ul style="list-style-type: none"> • Dot turned into smear • Black turned into blue and red 	<ul style="list-style-type: none"> • Smear got longer (3.0 cm) • Water went up paper (5.0 cm) • Blue, pink, red, and orange all seen

2

VARIABLES	
Variable	How will changing this variable affect the smears?
Pen Type	Smears will be longer if the pen type is _____. Pen type will _____ the colors of the smear.
Paper Type	Smears will be longer if the paper type is _____. Paper type will _____ the colors of the smear.
Liquid Type	Smears will be longer if the liquid type is _____. Liquid type will _____ the colors of the smear.
Choose your own!	

3

VARIABLES	
Variable	How will changing this variable affect the smears?
Pen Type	Smears will be longer if the pen type is not permanent. Pen type will change the colors of the smear.
Paper Type	Smears will be longer if the paper type is more absorbent. Paper type will not change the colors of the smear.
Liquid Type	Smears will be longer if the liquid type is thinner. Liquid type will not change the colors of the smear.
Time	Smears will be longer if the time is longer. Time will change the colors of the smear.
Pen Color	Pen color will not affect the height of the smear. Pen color will change the colors of the smear.

3

Preparation:

SciTrek Lead:

1. Make sure volunteers are passing out nametags.
2. Make sure volunteers are setting up for the initial observation.
3. Set up the document camera for the class question (notebook, front cover).
4. Pass out the conclusion assessments.

SciTrek Volunteers:

1. Pass out nametags.
 - a. You may need to do this during the Introduction. Quietly set each student's nametag on their desk without talking to them. If names are not written on their desk, ask the classroom teacher or lead to help you when they are not talking with the class.
2. Assemble the experimental set-up (shown in picture below as well as in color in the experimental set-up picture in your group box) on a tray.
 - a. Fill a 10 mL graduated cylinder with 2 mL of water.
 - b. Place the test tube (with cap) in the test tube stand.
 - c. Set the piece of chromatography paper (with the pencil line drawn at 2 cm from the bottom of the paper), test tube & stand, graduated cylinder with 2 mL of water, black Mr. Sketch marker, paper towel, timer, ruler, and 5 boxes of crayons on the tray.



Introduction:

(2 minutes – Full Class – SciTrek Lead)

For UCSB Lead:

“Hi, we are scientists from UCSB and we want to show you what we do as scientists. We will show you an experiment and then you can make observations, come up with a class question, and design your own experiment to help answer the class question. We want to show you that you can do science and have fun.”

For Teacher Lead:

“I have asked some scientists from UCSB to come and help us with a long-term science investigation. We will make observations, come up with a class question, and you will design your own experiment to help answer the class question.”

Allow the UCSB volunteers to introduce themselves and share their majors.

Conclusion Assessment:

(10 minutes – Full Class – SciTrek Lead)

Tell students, “Before we start with the module, we will determine how your ideas on conclusions are developing.” Have students write their name, teacher’s name, and date at the top of the assessment. Tell students, “When doing this assessment, you should work individually, so there should be no talking.” As you are giving the assessment, walk around the room and verify students have written their names on their assessments.

For page 1 (top), read questions 1 and 2 aloud and give students time to answer each before moving on to the next question.

For page 1, question 3 (bottom), read the instructions to students. Then, read each of the statements aloud and have students circle whether the statement is an example of a claim, data, or opinion.

For page 2 (top), have students annotate the results table by underlining controls, circling changing variables, and boxing information about data collection. Then, have them decide if the group could make a conclusion, question 4.

For page 2, question 5 (bottom), read step 1 of the instructions aloud to students (*Identify the following statements as either CLAIM or DATA and write a C or D on the line.*). Then, have students fill in whether they think statement *a* is a claim or data by writing a C or D on the line. Tell students, “This part is similar to question 3 of the assessment.” Read step 2 of the instructions aloud to students (*Look at the results table and circle if the statement is a correct claim, correct data, or incorrect. Statements are INCORRECT if*

the statement does not agree with the results table or has not been tested.). Point to the results table and have students circle whether they think statement *a* is a correct claim, correct data, or incorrect claim or data. Once students have completed statement *a*, read statement *b* aloud and tell students, “Write a C or D on the line depending on whether you think the statement is a claim or data.” After about 15 seconds tell students, “Now, look at the results table and circle whether the statement is a correct claim, correct data, or incorrect.” Repeat the process for statements *c-e*.

For page 3, questions 6-7, repeat the process.

When students are finished, collect the assessments and verify students’ names are written on the top of the papers.

Observation Discussion:

(2 minutes – Full Class – SciTrek Lead)

Tell students, “Scientists make many observations.” Ask the class, “What is an observation? What are the types of things you can record for an observation?” If they have trouble, show them an object and let them make observations. Turn these specific observations into general features of an observation. Examples of possible general observations are: color, texture, size, weight, temperature, etc. Lead students to understand an observation is a description using your five senses.

Tell students, “In this experiment we are going to make observations of a strip of paper at three different times. The first time will be *before* we put the paper in the test tube with water and the other two times will be *after* the paper is put in the test tube with water.” Remind them to record both written and illustrated observations in their notebooks.

Tell the class, “You will now get in your groups and make observations. To determine your group, you will need to look at the color of your nametag (orange, blue, or green).” Tell each colored group where to go, as well as to bring a pencil.

If a student does not have a nametag, identify the group color with the least number of students in it, and write the student’s name on one of the extra nametags in the lead box, using that color of marker.

Observations:

(26 minutes – Groups – SciTrek Volunteers)

Once students come over to your group, have them sit in boy/girl fashion. Verify the tray of materials is set up as described in the Set-Up section then, set the tray in the middle of the table. Pass out a notebook to each student. Have students fill out their name, teacher’s name, group color (color of their name on their nametag: orange, blue, or green), and their volunteer’s name on the front cover of their notebooks. Students will leave the subgroup number, and class question blank. Then, have students turn to page 2 of their notebooks.

As a group, have students generate approximately six observations about the experimental set-up. Observations should be recorded in the notepad under *Experimental Set-Up*, and then, copied by students into their notebooks. Observations about the experimental set-up should be recorded in bullet points to save time. Verify students know the container holding the liquid is called a ‘graduated cylinder,’ and it is used to measure liquid amounts. Make sure to record the following observations about the experimental set-up: liquid amount (2 ml), paper height (11.5 cm), line height on paper (2 cm). Encourage students to make other observations (~1 minute) that are not on the notepad and write them in their notebooks. This should take you no longer than 6 minutes.

With the black Mr. Sketch marker, make a dot in the middle of the line on the paper (the smaller the dot, the better the results). Have students look at the paper and tell them, “Remember what this looks like because this will be your ‘time 0’ observation.” Pour the 2 mL of water into the test tube. Bend the paper slightly length-wise (as seen in the picture on the right) so it will fit in the test tube. Then, place the paper, with the dot on the bottom, into the test tube, cap the system, and start the timer. It is important that this is done prior to having students record their time 0 observations so that enough time passes (~ 3 minutes) between time 0 and time 1. Record 0 seconds under the time, because this is when the strip of paper was put into the test tube. Then, have students draw a picture of their observations of the paper at time 0 using the black crayon. In addition, have students generate written measurements/observations and record these under the time 0 section of the table on the notepad and have students copy this information into their notebook.

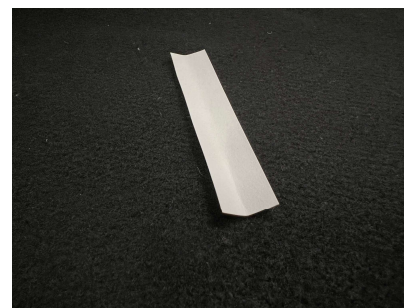

After students have completed their time 0 observations, record the time on the timer. This will be time 1 (~3 minutes). **Do not stop the timer, or take the strips out of the test tube a time 1.** Have students draw a picture of what the paper looks like at time 1 using the crayons on the tray. Make sure students draw their picture to match the strip of paper in front of them; a common mistake students make is drawing the dye colors going up from the bottom of the paper instead of up from the line. After their pictures are complete, make written observations as a group about time 1 and record these on the notepad and have the students copy this information into their notebooks.

After students have completed their time 1 observations, remove the paper and place it on a paper towel on the table. At the same time, stop the timer. Record this time (~7 minutes) for time 2 on the notepad. Ask students, “What do you see now, that will be gone by tomorrow?” They should reply, “The water line.” Tell students, “In order to know the location of the water, we use a pencil to trace the water level.” Have students draw a picture of the strip, including the water line, for time 2. Then, as a group, have students generate written measurements/observations and record these on the notepad. Make sure, in the time 2 measurements/observations section of the table, students record the height of the smear and the height of the liquid. Have students copy these /measurements/observations from the notepad into their notebooks.

If there is additional time, have students write a summary of what happened during the experiment. An example filled-out observations is shown below.

OBSERVATIONS			
Experimental Set-Up: <u>Black Mr. Sketch pen</u>			
<u>graduated cylinder with 2 mL of water</u>			
<u>paper 11.5 cm high with line on it at 2 cm</u>			
<u>timer</u>			
<u>5 boxes of crayons</u>			
<u>test tube and test tube holder</u>			
	Time 0	Time 1	Time 2
Time:	0 s	3 min 20 s	7 min 10 s
Picture:			
Measurements/ Observations:	<ul style="list-style-type: none"> • Small black dot on line (2cm) • Strip put into test tube with water 	<ul style="list-style-type: none"> • Dot turned into smear • Black turned into blue and red 	<ul style="list-style-type: none"> • Smear got longer (3.0 cm) • Water went up paper (5.0 cm) • Blue, pink, red and orange all seen

2

OBSERVATIONS			
Experimental Set-Up: <u>Black Mr. Sketch pen</u>			
<u>Graduated cylinder with 2 mL of water</u>			
<u>Paper 11.5 cm high with line on it at 2 cm</u>			
<u>Timer</u>			
<u>5 boxes of crayons</u>			
<u>Test tube and test tube holder</u>			
	Time 0	Time 1	Time 2
Time:	0 s	3 min 20 s	7 min 10 s
Picture:			
Measurements/ Observations:	<ul style="list-style-type: none"> • Small black dot on line (2 cm) • Strip put into test tube with water 	<ul style="list-style-type: none"> • Dot turned into smear • Black turned into blue and red 	<ul style="list-style-type: none"> • Smear got longer (3.0 cm) • Water went up paper (5.0 cm) • Blue, pink, red, and orange all seen

3

Variable Discussion:

(5 minutes – Full Class – SciTrek Lead)

Ask the class questions to review the experiment they carried out. Make sure, by the end of the discussion, students have described the set-up and identified what happened to the dot. Ask the class, "What was the most interesting observation?" Possible student response: the black dot spreading out into multiple colors. By the end of the discussion, make sure students agree to call the colored mark that formed, a 'smear.' Tell the class, "Since we are all interested in the smear, we will work together to answer the question, 'What variables affect smears?,' We will write this question on the front page of our notebooks." Write this question on the front page of the class notebook under the document camera, and have students copy the question onto the cover of their notebooks.

Lead students through the following questions, and explanations:

What does the word 'variable' mean to a scientist?

variables are the parts of the experiment you can change

Do you think there are multiple variables that will affect the smears?

multiple variables might affect the smears

Explain, this is why we will need to work as a class to answer the class question: "What variables affect smears?"

Tell the class, "You are going to think about variables, in the experiment, you could change, in order to help us answer the class question. In addition to generating variables, you should think about how and/or why these variables might affect the outcome of the experiment." Ask the class, "What do you think is a variable that might affect the smear?" Then, have them tell you how and why they think that variable would affect the height and color of the smear. Probe them on how they would design an experiment to test whether this variable affected the smear. Finally, have the students make a prediction of the results

for the experiment they proposed. Remind students, “Predictions can be wrong, and we will not know the true answers until we carry out the experiment.”

Ex: *Variable:* paper type

Why might this variable affect the smear? Different papers might absorb different amounts of liquid.

How would you test this variable? Get different types of paper and put black dots on them and put them in water.

Prediction: The more absorbent the paper, the taller the smear would be, but the colors of the smear would stay the same.

Tell students, “You will now generate more variables and analyze them, in your groups.”

Variables:

(12 minutes – Groups – SciTrek Volunteers)

As a group, generate a variable and make a prediction about how it could affect the height and color of the smear. Encourage and challenge students to explain why they think their prediction is correct, and how this variable could affect the smear. If needed, you can write down a sentence frame for students to use. Repeat this process two more times, record these ideas on the notepad and have students copy them into their notebooks. If students have different predictions, they can write their own predictions in their notebooks. Next, students will individually generate additional variables, make predictions about how different values of these variables will affect the smear, and record their ideas in their notebooks. Have students share these ideas with the group.

Prepare one student to share a variable and why they think it will affect the smear, during the class discussion.

VARIABLES	
Variable	How will changing this variable affect the smears?
Pen Type	Smears will be longer if the pen type is _____. Pen type will _____ the colors of the smear.
Paper Type	Smears will be longer if the paper type is _____. Paper type will _____ the colors of the smear.
Liquid Type	Smears will be longer if the liquid type is _____. Liquid type will _____ the colors of the smear.
Choose your own!	

3

VARIABLES	
Variable	How will changing this variable affect the smears?
Pen Type	Smears will be longer if the pen type is not permanent. Pen type will change the colors of the smear.
Paper Type	Smears will be longer if the paper type is more absorbent. Paper type will not change the colors of the smear.
Liquid Type	Smears will be longer if the liquid type is thinner. Liquid type will not change the colors of the smear.
Time	Smears will be longer if the time is longer. Time will change the colors of the smear.
Pen Color	Pen color will not affect the height of the smear. Pen color will change the colors of the smear.

3

Wrap-Up:

(3 minutes – Full Class – SciTrek Lead)

Have one student from each group share a variable they generated, as well as how and why they think it will affect the smear. Make sure, students tell you their predictions about how different values of that variable will affect the smear.

Tell students, “Next session, you will design an experiment to answer the class question: What variables affect smears?”

Clean-Up:

1. Collect notebooks with attached nametags.
2. Put the cap on the test tube so the water does not spill.
3. Place materials into your group box and bring them back to UCSB.

Day 2: Question/Materials Page/Experimental Set-Up/Procedure
Schedule:

Introduction (SciTrek Lead) – 13 minutes
 Question (SciTrek Volunteers) – 10 minutes
 Materials Page (SciTrek Volunteers) – 7 minutes
 Experimental Set-Up (SciTrek Volunteers) – 8 minutes
 Procedure (SciTrek Volunteers) – 19 minutes
 Wrap-Up (SciTrek Lead) – 3 minutes

Materials:
(3) Volunteer Boxes:

- | | | |
|---|--|--|
| <input type="checkbox"/> Nametags | <input type="checkbox"/> Volunteer lab coat | <input type="checkbox"/> (2) Pencils |
| <input type="checkbox"/> Notebooks | <input type="checkbox"/> (3) Materials pages (subgroup color & number indicated) | <input type="checkbox"/> (2) Red pens |
| <input type="checkbox"/> Volunteer instructions | | <input type="checkbox"/> Paper notepad |

Lead Box:

- | | | |
|--|--|--|
| <input type="checkbox"/> (3) Blank nametags | <input type="checkbox"/> Lead lab coat | <input type="checkbox"/> (2) Wet erase markers |
| <input type="checkbox"/> (3) Extra notebooks | <input type="checkbox"/> (3) Materials pages | <input type="checkbox"/> (2) Black pens |
| <input type="checkbox"/> Lead instructions | <input type="checkbox"/> Time card | <input type="checkbox"/> (3) Markers (orange, blue, green) |
| <input type="checkbox"/> Chromatography picture packet | <input type="checkbox"/> (2) Pencils | <input type="checkbox"/> Paper notepad |
| | <input type="checkbox"/> (2) Red pens | |

Notebook Pages:

Experimental Considerations:

- You will only have access to the materials on the materials page.
- The strips of paper cannot be in the liquid for more than 5 minutes.
- All strips of paper must be put into the liquid at the same time.

Changing Variable(s) (Independent Variable(s))

You will get to perform two experiments. For your first experiment, decide which variable(s) (max three) you would like to test. For each changing variable you select, discuss with your subgroup why you think that variable will affect the smear.

Changing Variable 1: Liquid Type
Discuss with your subgroup how you think **changing variable 1** will affect the smear.

Changing Variable 2 (optional): Pen Type
Discuss with your subgroup how you think **changing variable 2** will affect the smear.

Changing Variable 3 (optional): Initial Dot Height
Discuss with your subgroup how you think **changing variable 3** will affect the smear.

QUESTION

Question our subgroup will investigate:

- If we change the liquid type, pen type, and initial dot height insert each changing variable (independent variable), what will happen to the height and color of the smear insert what you are measuring/observing (dependent variable)?

SciTrek Member Approval: DF

Get a materials page from your volunteer and fill it out before moving onto the experimental set-up.

4

EXPERIMENTAL SET-UP

Write your changing variable(s) (Ex: pen color) and the values (Ex: blue) you will use for your trials under each strip of paper.

A

B

C

D

Changing Variable(s):

- Liquid Type : RA Vinegar Water Soap
- Pen Type : Mr. Sketch Expo Bic Dry Erase
- Initial Dot Height : 1 cm 7 cm 3 cm 5 cm

Controls (variables you will hold constant):
Write your controls and the values you will use in all your trials (control/value, Ex: container/test tube).

Container / Test Tube Paper Type / Original
Time / 5 min Pen Color / Black
Liquid Amount / 5 mL Cap Placement / On

SciTrek Member Approval: DF

5

PROCEDURE

Procedure Note:
Make sure to include all values of your changing variable(s) in the procedure (Ex: For a subgroup that decided to change pen color, one step would be: Put colored dot with Mr. Sketch pens A) red, B) blue, C) green, and D) yellow on original paper at 2 cm.)

- Fill 4 test tubes with 5 mL of A) RA, B) vinegar, C) water, and D) soap.
- Draw dots on original papers at A) 1 cm, B) 7 cm, C) 3 cm, and D) 5 cm with a black A) Mr. Sketch, B) Expo, C) Bic, and D) dry erase pen.
- Put papers in test tubes and put cap on.
- Wait 5 minutes.
- Remove papers.
- Measure smear heights and observe smear colors.

SciTrek Member Approval: DF

6

Preparation:

SciTrek Lead:

1. Make sure volunteers are setting out notebooks in such a way that allows students within the same subgroup to work together.
2. Set up the document camera for the example Day 1 strip (picture packet, page 1), question (notebook, page 4), materials page (lead box), and experimental set-up (notebook, page 5).

SciTrek Volunteers:

1. Set out notebooks/nametags to allow students in the same subgroup (same number on the front of their notebook) to work together.
2. Make sure you have three materials pages, each filled out with a subgroup number (1, 2, or 3) and your group's color, to give to subgroups after they complete their question.
3. Have a red pen available to approve subgroups' questions, experimental set-ups, and procedures (notebook, pages 4-6).

Note: Set notebooks where students will sit during the module, even if another student is currently at that desk. If needed, students will move to these spots after the Introduction.

Introduction:

(13 minutes – Full Class – SciTrek Lead)

If students are not in their subgroups, tell them, "A notebook will be put on your desk, which is not your notebook and you should not move it. You will move to your notebook after the Introduction."

Ask students, "What did we do and learn during our last session?" Then, show them the picture of the example strip (picture packet, page 1) to help remind them. Possible student response: we put a black dot on a piece of paper and observed that the dot separated into different colors when the paper absorbed water. We also generated variables that might affect the smear. Ask the class, "What is the class question we will be investigating?" Students should reply, "What variables affect smears?"

Tell students, "One way scientists answer questions is by performing experiments. Today, you will design an experiment to help answer the class question." Ask the class, "Do you think there are multiple variables that could affect the smear?" Possible student response: there are probably multiple variables.

Explain to students, "Many times, when there is a broad question, like our class question, scientists break it down into smaller, more specific questions which small groups of scientists can investigate. The scientists then compile their work to answer the broader question. Therefore, each subgroup is going to generate a smaller question to investigate. Once we put all the subgroups' research together, we should be able to answer the class question."

Subgroups will first generate a question based on the changing variable(s) they plan to explore. They will then fill out their materials page, which will allow them to determine their experimental set-up. The experimental set-up will help them generate a procedure, or a set of steps to conduct an experiment. Go over the experimental considerations (notebook, page 4) with students so they understand the limitations in the experiments they can design.

Experimental Considerations:

1. *You will only have access to the materials on the materials page.*
2. *The strips of paper cannot be in the liquid for more than 5 minutes.*
3. *All strips of paper must be put into the liquid at the same time.*

Tell students, “We are now going to generate an example question/experimental set-up together. I will write it in the class notebook, so you will be able to refer back to it when you are completing the process yourselves.” Make sure students **do not** fill out the example question/experimental set-up in their notebooks, as they will be completing these pages for their own experiments in subgroups.

Tell students, “For the example experiment, the changing variables will be liquid amount and pen color.” Note: As an alternative you can choose any other two changing variables as long as one has numeric values and the other has word values. Then, write down the changing variables in the class notebook (notebook, page 4), under the document camera. Tell students, “When you are going through this process in your subgroups, you may select one, two, or three changing variables.”

Show students how to insert the changing variables and what they plan to measure/observe into the question frame to generate the question that will be investigated, “If we change the liquid amount and pen color, what will happen to the height, and color, of the smear?”

Experimental Considerations:

1. You will only have access to the materials on the materials page.
2. The strips of paper cannot be in the liquid for more than 5 minutes.
3. All strips of paper must be put into the liquid at the same time.

Changing Variable(s) (Independent Variable(s))

You will get to perform two experiments. For your first experiment, decide which variable(s) (max three) you would like to test. For each changing variable you select, discuss with your subgroup why you think that variable will affect the smear.

Changing Variable 1: Liquid Amount
 Discuss with your subgroup how you think **changing variable 1** will affect the smear.

Changing Variable 2 (optional): Pen Color
 Discuss with your subgroup how you think **changing variable 2** will affect the smear.

Changing Variable 3 (optional): _____
 Discuss with your subgroup how you think **changing variable 3** will affect the smear.

QUESTION

Question our subgroup will investigate:

- If we change the liquid amount and pen color
insert each changing variable (independent variable)

what will happen to the height and color of the
insert what you are measuring/observing (dependent variable)
smear ?

SciTrek Member Approval: _____

Get a materials page from your volunteer and fill it out before moving onto the experimental set-up.

4

Tell students, “Once you have determined your question, and have approval, your volunteer will give you a materials page for determining the values of your controls and changing variable(s).” Ask students, “What is a control?” Make sure, by the end of the conversation, students understand controls are variables that are held constant during an experiment. For example, if the pen type was Mr. Sketch for all of the trials, then one of their controls would be pen type. These controls, and control values, can be different from the original experiment they conducted on Day 1, but must remain constant throughout all the trials they do for this experiment.

Show students the materials page (lead box), and read the first step (*For each bolded word, underline if it is a control and circle if it is a changing variable.*). Then, have students tell you what to do for each bolded word. Read steps 2 and 3 on the materials page (*For variables that are controls, choose 1 value. For variables that are changing variables, choose 4 values and write the trial letter next to each value.*). Read the general materials to students, ask them if they need each one, and check the box when they say yes.

Go through the remaining items on the materials page. If a variable is a control, then choose (do not let students choose) a single value, such as the original value (Ex: water for liquid type). Make sure to follow all restrictions listed (Ex: liquid amount may only be 0 ml – 20 ml). Assign each control value to a student, and tell them, “You are in charge of remembering this control, and its value, to help when filling out the experimental set-up.” For variables that are changing variables, allow students to select the values. Write the trial letter next to each selected value. Ask students, “Do we want a narrow, or wide, range of values for the changing variables and why?” Guide students through selecting a wide range of values for both changing variables. If they choose a value contrary to their proposed experimental design, question them on their reasoning. For example, if they said they wanted to use a wide range of liquid amounts, and they picked 10 ml, 11 ml, 12 ml, and 13 ml, ask them, “Would the selected values allow us to best answer the question?” Allow them to change their values if needed. Assign the changing variable values to the students who chose them to remember for the experimental set up.

<p style="text-align: center;">Color (circle one): Orange Blue Green Group Number (circle one): 1 2 3</p> <p style="text-align: center;">MATERIALS PAGE</p> <p>You will only have access to the following materials.</p> <ol style="list-style-type: none"> For each bolded word, underline it if it is a control and circle it if it is a changing variable. Example control: <u>Liquid Type</u>. Example changing variable: <u>Pen Type</u>. For variables that are controls, choose 1 value. For variables that are changing variables, choose 4 values and write the trial letter (A,B,C,D or E,F,G,H) next to each value. Example: <input checked="" type="checkbox"/> Crayola A <p>General Materials:</p> <table style="width: 100%;"> <tr> <td><input checked="" type="checkbox"/> 4 test tubes with caps</td> <td><input checked="" type="checkbox"/> test tube rack</td> <td><input checked="" type="checkbox"/> timer</td> </tr> <tr> <td><input checked="" type="checkbox"/> 2 rulers</td> <td><input checked="" type="checkbox"/> 2 droppers</td> <td><input checked="" type="checkbox"/> 2 graduated cylinders</td> </tr> </table> <p>Liquid Type:</p> <table style="width: 100%;"> <tr> <td><input type="checkbox"/> rubbing alcohol (RA)</td> <td><input type="checkbox"/> soap</td> <td><input type="checkbox"/> vinegar</td> </tr> <tr> <td colspan="3"><input checked="" type="checkbox"/> water</td> </tr> </table> <p>Liquid Amount: <u>(A) 1 mL, (B) 20 mL, (C) 5 mL, (D) 10 mL</u> Any amount up to 20 mL (original liquid amount = 2 mL)</p> <p>Paper Type:</p> <table style="width: 100%;"> <tr> <td><input checked="" type="checkbox"/> original paper</td> <td><input type="checkbox"/> coffee filter</td> <td><input type="checkbox"/> copy paper</td> <td><input type="checkbox"/> paper towel</td> </tr> <tr> <td><input type="checkbox"/> graph paper</td> <td><input type="checkbox"/> newspaper</td> <td colspan="2"><input type="checkbox"/> construction paper</td> </tr> </table> <p>Pen Type:</p> <table style="width: 100%;"> <tr> <td><input checked="" type="checkbox"/> Mr. Sketch (original)</td> <td><input type="checkbox"/> Crayola</td> <td><input type="checkbox"/> Expo</td> </tr> <tr> <td><input type="checkbox"/> Sharpie</td> <td><input type="checkbox"/> Rose Art</td> <td><input type="checkbox"/> Bic (Black Only)</td> </tr> <tr> <td><input type="checkbox"/> Dry Erase (Black Only)</td> <td colspan="2"><input type="checkbox"/> Paper Mate (Black Only)</td> </tr> </table> <p>Pen Color:</p> <table style="width: 100%;"> <tr> <td><input checked="" type="checkbox"/> red <u>A</u></td> <td><input type="checkbox"/> orange</td> <td><input checked="" type="checkbox"/> yellow <u>D</u></td> <td><input type="checkbox"/> green</td> </tr> <tr> <td><input checked="" type="checkbox"/> blue <u>B</u></td> <td><input type="checkbox"/> purple</td> <td><input type="checkbox"/> black (original)</td> <td><input type="checkbox"/> brown</td> </tr> </table> <p>The following colors can only be chosen if your pen type is Mr. Sketch.</p> <table style="width: 100%;"> <tr> <td><input type="checkbox"/> light pink</td> <td><input type="checkbox"/> dark pink</td> <td><input type="checkbox"/> light blue</td> <td><input checked="" type="checkbox"/> light green <u>C</u></td> </tr> </table> <p>Initial Dot Height: <u>2 cm</u> Any height up to 11.5 cm (original dot height = 2 cm)</p> <p>Time: <u>5 min</u> Any time up to 5 minutes</p> <div style="border: 1px solid black; padding: 5px; text-align: center; margin-top: 10px;">Materials Page</div>	<input checked="" type="checkbox"/> 4 test tubes with caps	<input checked="" type="checkbox"/> test tube rack	<input checked="" type="checkbox"/> timer	<input checked="" type="checkbox"/> 2 rulers	<input checked="" type="checkbox"/> 2 droppers	<input checked="" type="checkbox"/> 2 graduated cylinders	<input type="checkbox"/> rubbing alcohol (RA)	<input type="checkbox"/> soap	<input type="checkbox"/> vinegar	<input checked="" type="checkbox"/> water			<input checked="" type="checkbox"/> original paper	<input type="checkbox"/> coffee filter	<input type="checkbox"/> copy paper	<input type="checkbox"/> paper towel	<input type="checkbox"/> graph paper	<input type="checkbox"/> newspaper	<input type="checkbox"/> construction paper		<input checked="" type="checkbox"/> Mr. Sketch (original)	<input type="checkbox"/> Crayola	<input type="checkbox"/> Expo	<input type="checkbox"/> Sharpie	<input type="checkbox"/> Rose Art	<input type="checkbox"/> Bic (Black Only)	<input type="checkbox"/> Dry Erase (Black Only)	<input type="checkbox"/> Paper Mate (Black Only)		<input checked="" type="checkbox"/> red <u>A</u>	<input type="checkbox"/> orange	<input checked="" type="checkbox"/> yellow <u>D</u>	<input type="checkbox"/> green	<input checked="" type="checkbox"/> blue <u>B</u>	<input type="checkbox"/> purple	<input type="checkbox"/> black (original)	<input type="checkbox"/> brown	<input type="checkbox"/> light pink	<input type="checkbox"/> dark pink	<input type="checkbox"/> light blue	<input checked="" type="checkbox"/> light green <u>C</u>	<p style="text-align: center;">EXPERIMENTAL SET-UP</p> <p>Write your changing variable(s) (Ex: pen color) and the values (Ex: blue) you will use for your trials under each strip of paper.</p> <div style="display: flex; justify-content: space-around; align-items: center; margin: 10px 0;"> <div style="border: 1px solid black; width: 20px; height: 60px; text-align: center; line-height: 60px;">A</div> <div style="border: 1px solid black; width: 20px; height: 60px; text-align: center; line-height: 60px;">B</div> <div style="border: 1px solid black; width: 20px; height: 60px; text-align: center; line-height: 60px;">C</div> <div style="border: 1px solid black; width: 20px; height: 60px; text-align: center; line-height: 60px;">D</div> </div> <p>Changing Variable(s):</p> <p>1) <u>Liquid Amount</u> : <u>1 mL</u> <u>20 mL</u> _____</p> <p>2) <u>Pen Color</u> : <u>Red</u> <u>Blue</u> _____</p> <p>3) _____ : _____</p> <p>Controls (variables you will hold constant): Write your controls and the values you will use in all your trials (control/value, Ex: container/test tube).</p> <table style="width: 100%; border-collapse: collapse;"> <tr> <td style="border-bottom: 1px solid black;">Container</td> <td style="border-bottom: 1px solid black;">/</td> <td style="border-bottom: 1px solid black;">Test Tube</td> <td style="border-bottom: 1px solid black;">Paper Type</td> <td style="border-bottom: 1px solid black;">/</td> <td style="border-bottom: 1px solid black;">Original</td> </tr> <tr> <td style="border-bottom: 1px solid black;">Time</td> <td style="border-bottom: 1px solid black;">/</td> <td style="border-bottom: 1px solid black;">5 min</td> <td style="border-bottom: 1px solid black;">Pen Type</td> <td style="border-bottom: 1px solid black;">/</td> <td style="border-bottom: 1px solid black;">Mr. Sketch</td> </tr> <tr> <td style="border-bottom: 1px solid black;">Liquid Type</td> <td style="border-bottom: 1px solid black;">/</td> <td style="border-bottom: 1px solid black;">Water</td> <td style="border-bottom: 1px solid black;">Initial Dot Height</td> <td style="border-bottom: 1px solid black;">/</td> <td style="border-bottom: 1px solid black;">2 cm</td> </tr> <tr> <td colspan="3"></td> <td style="border-bottom: 1px solid black;">Cap Placement</td> <td style="border-bottom: 1px solid black;">/</td> <td style="border-bottom: 1px solid black;">On</td> </tr> </table> <p style="text-align: right; margin-top: 10px;">SciTrek Member Approval: _____</p>	Container	/	Test Tube	Paper Type	/	Original	Time	/	5 min	Pen Type	/	Mr. Sketch	Liquid Type	/	Water	Initial Dot Height	/	2 cm				Cap Placement	/	On
<input checked="" type="checkbox"/> 4 test tubes with caps	<input checked="" type="checkbox"/> test tube rack	<input checked="" type="checkbox"/> timer																																																																
<input checked="" type="checkbox"/> 2 rulers	<input checked="" type="checkbox"/> 2 droppers	<input checked="" type="checkbox"/> 2 graduated cylinders																																																																
<input type="checkbox"/> rubbing alcohol (RA)	<input type="checkbox"/> soap	<input type="checkbox"/> vinegar																																																																
<input checked="" type="checkbox"/> water																																																																		
<input checked="" type="checkbox"/> original paper	<input type="checkbox"/> coffee filter	<input type="checkbox"/> copy paper	<input type="checkbox"/> paper towel																																																															
<input type="checkbox"/> graph paper	<input type="checkbox"/> newspaper	<input type="checkbox"/> construction paper																																																																
<input checked="" type="checkbox"/> Mr. Sketch (original)	<input type="checkbox"/> Crayola	<input type="checkbox"/> Expo																																																																
<input type="checkbox"/> Sharpie	<input type="checkbox"/> Rose Art	<input type="checkbox"/> Bic (Black Only)																																																																
<input type="checkbox"/> Dry Erase (Black Only)	<input type="checkbox"/> Paper Mate (Black Only)																																																																	
<input checked="" type="checkbox"/> red <u>A</u>	<input type="checkbox"/> orange	<input checked="" type="checkbox"/> yellow <u>D</u>	<input type="checkbox"/> green																																																															
<input checked="" type="checkbox"/> blue <u>B</u>	<input type="checkbox"/> purple	<input type="checkbox"/> black (original)	<input type="checkbox"/> brown																																																															
<input type="checkbox"/> light pink	<input type="checkbox"/> dark pink	<input type="checkbox"/> light blue	<input checked="" type="checkbox"/> light green <u>C</u>																																																															
Container	/	Test Tube	Paper Type	/	Original																																																													
Time	/	5 min	Pen Type	/	Mr. Sketch																																																													
Liquid Type	/	Water	Initial Dot Height	/	2 cm																																																													
			Cap Placement	/	On																																																													

Tell students, “Once you have completed your materials page, you will fill out your experimental set-up. First, you will fill out the information on the changing variable(s).” Ask students, “What are the changing variables for the example experiment, and what values did we select?” Then, fill in the values, for trials A and B only. Tell students, “Second, you will fill in information about your controls.” Draw an additional control line under the existing control list. Ask students, “What is one of the controls, and its value, for the example experiment?” Show students how to record the control on the left side of the slash (Ex: liquid amount), and the value of that control on the right side of the slash (Ex: 2 ml) by doing so in the class notebook. There are seven possible variables to choose from on the materials page. If a subgroup changes three variables, they will be left with one control blank empty after inserting in the information from the materials page. Since all control blanks must be filled out, tell students, “You may need to generate an additional control that does not come from the materials page.” Lead students to realize this should be “cap placement/on.”

Ask students, “Should everyone choose the same changing variable and why or why not?” Possible student response: no, because we will not learn as much about the class question. Tell students, “This means you should try to explore a changing variable you think few other subgroups are exploring. Once

your subgroup has completed your experimental set-up, you should raise your hands and get it approved by your volunteer.” Above is an example of what should be filled out for the experimental set-up in the class notebook. Note that several sections are left blank by the lead, but students will fill these in for their own notebooks.

Tell students, “After you finish your experimental set-up, you will write a procedure for your experiment that you will be able to follow next session. When writing a procedure, you should include all values of your controls, and changing variable(s), as well as what data you will collect.” Show students the example procedure step on page 6 of their notebook (*Put colored dot with Mr. Sketch pens A) red, B) blue, C) green, and D) yellow on original paper at 2 cm.*). Tell students, “Once your procedure is completed, you will get it approved by a volunteer.”

Have students start the design process. Place the example question (notebook, page 4) under the document camera so students may refer to it as they design their experiments. As subgroups move onto their experimental set-ups, put the example experimental set-up (notebook, page 5) under the document camera.

Question:

(10 minutes – Subgroups – SciTrek Volunteers)

Have subgroups decide what changing variable(s) they want to explore for their first experiment. Do not try and sway students in any particular direction when choosing their number of changing variables. If they only have one changing variable, do not encourage them to have more. If they have two/three changing variables, do not encourage them to have fewer. Students will analyze their data, and then perform an additional experiment to correct any mistakes they made on their first experiment.

After subgroups have decided on their changing variable(s), have them fill out their question. When you sign off on their question, give them a materials page with their subgroup color and number designated in the upper right-hand corner. An example filled-out question is shown below.

Experimental Considerations:

1. You will only have access to the materials on the materials page.
2. The strips of paper cannot be in the liquid for more than 5 minutes.
3. All strips of paper must be put into the liquid at the same time.

Changing Variable(s) (Independent Variable(s))

You will get to perform two experiments. For your first experiment, decide which variable(s) (max three) you would like to test. For each changing variable you select, discuss with your subgroup why you think that variable will affect the smear.

Changing Variable 1: Liquid Type
 Discuss with your subgroup how you think **changing variable 1** will affect the smear.

Changing Variable 2 (optional): Pen Type
 Discuss with your subgroup how you think **changing variable 2** will affect the smear.

Changing Variable 3 (optional): Initial Dot Height
 Discuss with your subgroup how you think **changing variable 3** will affect the smear.

QUESTION

Question our subgroup will investigate:

- If we change the liquid type, pen type, and initial dot height
insert each changing variable (independent variable)
 what will happen to the height and color of the smear
insert what you are measuring/observing (dependent variable) ?

SciTrek Member Approval: DF

Get a materials page from your volunteer and fill it out before moving onto the experimental set-up.

4

Materials Page:

(7 minutes – Subgroups – SciTrek Volunteers)

Have subgroups underline their controls and circle their changing variable(s) on the materials page. Then, have them use the materials page to choose the values for their controls and changing variable(s). For the changing variable(s) values, have students write the trial letter (A, B, C, D) next to the value they select. Ask students, “Why did you choose the values you did for your controls and changing variable(s)?, Will these values make it easier or harder to answer your question?”

Make sure students have picked liquid amounts, initial dot heights, and times, that are within the limitations given on the materials page. An example filled-out materials page is shown in the Experimental Set-Up section below.

Experimental Set-Up:

(8 minutes – Subgroups – SciTrek Volunteers)

Have subgroups use their materials page to fill in their experimental set-ups (notebook, page 5). For subgroups who have three changing variables, there will be one control blank that will not come from the materials page. For this control, students should write “cap placement/on.” When you sign off on their experimental set-ups, ensure all students within a subgroup have the same trial letters corresponding to the same changing variable values; then, collect the materials page and verify that it is filled out correctly and completely. Filling out the materials page is essential for students to obtain the correct materials for their experiments on Day 3. An example filled-out experimental set-up is shown below (right).

Color (circle one): Orange Blue Green
 Group Number (circle one): 1 2 3

MATERIALS PAGE

You will only have access to the following materials.

- For each bolded word, underline it if it is a control and circle it if it is a changing variable. Example control: Liquid Type, Example changing variable: Pen Type
- For variables that are controls, choose 1 value.
- For variables that are changing variables, choose 4 values and write the trial letter (A,B,C,D or E,F,G,H) next to each value. Example: Crayola A

General Materials:

4 test tubes with caps test tube rack timer
 2 rulers 2 droppers 2 graduated cylinders

Liquid Type:

rubbing alcohol (RA) A soap D vinegar B
 water C

Liquid Amount: 5 mL
 Any amount up to 20 mL (original liquid amount = 2 mL)

Paper Type:

original paper coffee filter copy paper paper towel
 graph paper newspaper construction paper

Pen Type:

Mr. Sketch (original) A Crayola Expo B
 Sharpie Rose Art Bic (Black Only) C
 Dry Erase (Black Only) D Paper Mate (Black Only)

Pen Color:

red orange yellow green
 blue purple black (original) brown
 The following colors can **only** be chosen if your pen type is Mr. Sketch.
 light pink dark pink light blue light green

Initial Dot Height: A) 1 cm, B) 7 cm, C) 3 cm, D) 5 cm
 Any height up to 11.5 cm (original dot height = 2 cm)

Time: 5 min
 Any time up to 5 minutes

Materials Page

EXPERIMENTAL SET-UP

Write your changing variable(s) (Ex: pen color) and the values (Ex: blue) you will use for your trials under each strip of paper.

A

B

C

D

Changing Variable(s):

- Liquid Type : RA Vinegar Water Soap
- Pen Type : Mr. Sketch Expo Bic Dry Erase
- Initial Dot Height : 1 cm 7 cm 3 cm 5 cm

Controls (variables you will hold constant):
 Write your controls and the values you will use in all your trials (control/value, Ex: container/test tube).

Container / Test Tube Paper Type / Original
Time / 5 min Pen Color / Black
Liquid Amount / 5 mL Cap Placement / On

SciTrek Member Approval: DF

5

Procedure:

(19 minutes – Subgroups – SciTrek Volunteers)

After each subgroup has filled out their experimental set-up, they can start on their procedure (notebook, page 6). Make sure students within the same subgroup are collaborating to write their procedure. Keep procedures as brief as possible, while still conveying the pertinent information (control values, changing variable values, and the data they will collect) about the experiment. An example step for a subgroup who had pen color as a changing variable would be, “Put colored dot with Mr. Sketch A) red, B) blue, C) green, and D) yellow on original paper at 2 cm.” Some subgroups may struggle with writing procedures. You can have these subgroups dictate each step while you transcribe them onto a notepad found in your group box. Give this sheet to students to copy into their notebooks. Once students have finished, they should raise their hands and get their procedures approved by their volunteer. An example filled-out procedure is shown below.

PROCEDURE

Procedure Note:
 Make sure to include all values of your changing variable(s) in the procedure (Ex: For a subgroup that decided to change pen color, one step would be: Put colored dot with Mr. Sketch pens A) red, B) blue, C) green, and D) yellow on original paper at 2 cm.)

1. Fill 4 test tubes with 5 mL of A) RA, B) vinegar, C) water, and D) soap.
2. Draw dots on original papers at A) 1 cm, B) 7 cm, C) 3 cm, and D) 5 cm with a black A) Mr. Sketch, B) Expo, C) Bic, and D) dry erase pen.
3. Put papers in test tubes and put cap on.
4. Wait 5 minutes.
5. Remove papers.
6. Measure smear heights and observe smear colors.

SciTrek Member Approval DF
6

If there is time, have your subgroups fill out the variables and prediction section of the results table (see Day 3 for directions and example page).

Wrap-Up:

(3 minutes – Full Class – SciTrek Lead)

If there is time, have one student from each subgroup share what question they will investigate. Tell students, “Next session, you will start your experiments. All of your experiments will help us answer the class question: What variables affect smears?”

Clean-Up:

1. Collect notebooks with attached nametags.
2. Place materials into your group box and bring them back to UCSB.

Day 3: Results Table/Experiment/Graph/Conclusion Activity

Schedule:

- Introduction (SciTrek Lead) – 8 minutes
- Results Table (SciTrek Volunteers) – 3 minutes
- Experiment (SciTrek Volunteers) – 17 minutes
- Graph (SciTrek Volunteers) – 10 minutes
- Conclusion Activity (SciTrek Lead) – 20 minutes
- Wrap-Up (SciTrek Lead) – 2 minutes

Materials:

(3) Volunteer Boxes:

- | | | |
|---|---|--|
| <input type="checkbox"/> Nametags | <input type="checkbox"/> Paper notepad | <input type="checkbox"/> (12) Small cups (labeled with liquid types) |
| <input type="checkbox"/> Notebooks | <input type="checkbox"/> (6) Rulers | <input type="checkbox"/> Vinegar |
| <input type="checkbox"/> Volunteer instructions | <input type="checkbox"/> Paper towels | <input type="checkbox"/> Soap |
| <input type="checkbox"/> Volunteer lab coat | <input type="checkbox"/> Water | <input type="checkbox"/> Rubbing alcohol |
| <input type="checkbox"/> (3) Pencils | <input type="checkbox"/> (3) Test tube stands | |
| <input type="checkbox"/> (2) Red pens | | |
- (3) Ziploc bags (quart size), labeled (with subgroup number), each with the following:
- | | | |
|--|--|--|
| <input type="checkbox"/> Wet erase pen | <input type="checkbox"/> (2) Droppers | <input type="checkbox"/> Paper towel |
| <input type="checkbox"/> (2) 10 mL Graduated cylinders | <input type="checkbox"/> Requested strips of paper | <input type="checkbox"/> Timer |
| <input type="checkbox"/> (4) Test tubes with caps | <input type="checkbox"/> Requested pens | <input type="checkbox"/> Filled-out materials page |

Other Supplies:

-
- Bucket with lid

Lead Box:

- | | | |
|--|---|---|
| <input type="checkbox"/> (3) Extra notebooks | <input type="checkbox"/> Black pens | <input type="checkbox"/> Bag 1: lead chromatography supplies ((4) 10 mL graduated cylinders, (8) test tubes with caps, (8) droppers, (12) small cups (labeled with liquid types), paper towels) |
| <input type="checkbox"/> Lead instructions | <input type="checkbox"/> Paper notepad | <input type="checkbox"/> Bag 2: lead chromatography supplies (chromatography paper (minimum 30), 6 paper types (minimum 20 each), 8 different black pens, 5 sets of different colored markers) |
| <input type="checkbox"/> Chromatography picture packet | <input type="checkbox"/> (6) Rulers | |
| <input type="checkbox"/> Lead lab coat | <input type="checkbox"/> (2) Timers | |
| <input type="checkbox"/> Time card | <input type="checkbox"/> Water | |
| <input type="checkbox"/> (2) Pencils | <input type="checkbox"/> (2) Test tube stands | |
| <input type="checkbox"/> (2) Red pens | <input type="checkbox"/> Vinegar | |
| <input type="checkbox"/> (2) Wet erase markers | <input type="checkbox"/> Soap | |
| | <input type="checkbox"/> Rubbing alcohol | |

Notebook Pages:

RESULTS
Table

Fill out the table for each of your trials. For the variables that remain constant, write the value in trial A and then draw an arrow through each box indicating that this variable is a control.

Variables	Trial A	Trial B	Trial C	Trial D
Container:	Test Tube			
Time:	5 min			
Liquid Type:	RA	Vinegar	Water	Soap
Liquid Amount:	5 mL			
Paper Type:	Original			
Pen Color:	Black			
Pen Type:	Mr. Sketch	Expo	Bic	Dry Erase
Initial Dot Height:	1 cm	7 cm	3 cm	5 cm
Cap Placement:	On			
Predictions	Trial A	Trial B	Trial C	Trial D
Put a "T" in the trial that will give the tallest smear and an "S" in the trial that will give the shortest smear.	T		S	
Data	Trial A	Trial B	Trial C	Trial D
Smear Height:	8 cm	0.5 cm	0 cm	0 cm
Liquid Height:	8 cm	7.5 cm	8 cm	2 cm
Observations:	Smear went down and up black in liquid black, pink, purple	Yellow, red, blue, purple	Dot did not move	Liquid did not reach dot

The independent variable(s) is(are) the changing variable(s) and the dependent variables are the final measurements/observations.

RESULTS
Graph

Set up your graph. (Check off the steps as you complete them.)

- Label the y-axis (vertical) with what you measured, including units (Ex: smear height (cm)).
- Determine an appropriate scale which will allow you to graph all of your data points and write the numbers on the given lines.
- Label the x-axis (horizontal) with your changing variable(s) #1, #2, and #3 (Ex: liquid type). Changing variable #2 and #3 will only be filled in if you have 2 or 3 changing variables.
- On your results table, label your measurements from 1 to 4, with 1 being the trial with the smallest measurement and 4 being the trial with the largest measurement.

Plot your data in increasing order.

- Write the changing variable value(s) (Ex: soap) for the trial that you labeled 1 under the first column.
- Graph your data for that trial and write the measurement above the bar.
- Repeat the process for the other trials.

Liquid Type:	Water	Soap	Vinegar	RA
Changing Variable #1	Bic	Dry Erase	Expo	Mr. Sketch
Changing Variable #2	3 cm	5 cm	7 cm	1 cm
Changing Variable #3				

SCIENTIFIC PRACTICES
Conclusions

1. Directions: Fill in the missing definition.

- **Claim:** a claim supported by data
 - **Claim:** A statement that can be tested. The explanation of the data, the first part of a conclusion.
 - Ex: Cats, on average, weigh less than dogs
 - **Data:** Evidence collected from experiment(s) (measurements or observations), the second part of a conclusion.
 - Ex: the average weight of 4 dogs is 14 kg, and the average weight of 4 cats is 5 kg.

2. Directions: Circle if the statement is a CLAIM, DATA, or an OPINION.

- McDonald's served 100 customers and Taco Bell served 75 customers. Claim Data Opinion
- blue is the best color. Claim Data Opinion
- butterflies that are larger than 15 cm are attracted to bright colors. Claim Data Opinion
- ice was observed floating on water. Claim Data Opinion
- people buy more pizza than hamburgers. Claim Data Opinion
- the average male blue whale weighs 91,000 kg, while the average female blue whale weighs 72,000 kg. Claim Data Opinion
- the tastier the fruit, the more bugs on the fruit. Claim Data Opinion

Circles are your initial thoughts and boxes are the correct answer.

SCIENTIFIC PRACTICES
Conclusions

3. Directions: Draw a line connecting claims with the correct data. If there is no data that supports the claim, do not draw a line.

Claim	because	Data
1. People read more from electronic devices than books	/	a. Sony TVs give off <u>20 lumens</u> of light and Samsung TVs give off <u>10 lumens</u> of light.
2. Sony TVs are brighter than Samsung TVs	/	b. when blue and red paint were mixed the paint was <u>observed</u> to turn purple.
3. The color purple is made from blue and red	/	c. wind turbines produce 6,000 MW of energy and solar panels produce 5,000 MW of energy in California.
4. Wind turbines produce less energy than solar panels in California	/	d. the speed of light is measured to be $3 \times 10^8 \frac{m}{s}$

Preparation:

SciTrek Lead:

1. Make sure volunteers are setting out notebooks.
2. Make sure volunteers are setting up for the experiment.
3. Set up the document camera for the filled-out results table (picture packet, page 2), graph (notebook, page 8), and conclusion activity (notebook, pages 9 and 10).

SciTrek Volunteers:

1. Set out notebooks/nametags.
2. Pour all of the liquids your subgroups will need into the small, labeled cups.
3. Have test tube stands, liquids, bags with supplies (labeled with subgroup number), and rulers ready to give subgroups when they finish their results table.

Note: Set notebooks where students will sit during the module, even if another student is currently at that desk. If needed, students will move to these spots after the Introduction.

Introduction:
(8 minutes – Full Class – SciTrek Lead)

If students are not in their subgroups, tell them, “A notebook will be put on your desk, which is not your notebook and you should not move it. You will move to your notebook after the Introduction.”

Ask the class, “What is the class question we are investigating?” Students should reply, “What variables affect smears?” Tell students, “Today, you will conduct your experiments to answer this question. However, before you start your experiments, you need to fill out the results table (some students might have completed this in the previous session).” Put the filled-out results table (picture packet, page 2; below, left) under the document camera. Tell students, “You should first underline controls, circle changing variables, and box information about data collection. For controls, you will write the control value in the *Trial A* box. Then, draw an arrow through the remaining trials’ boxes. For the changing variable(s), you will write the changing variable value in each box.” Show students both of these on the filled-out results table. Tell students, “Once you have filled out your results table, you will make predictions about which trial will produce the shortest and tallest smears. You will write a ‘S’ in the box of the trial you think will produce the shortest smear, and an ‘T’ in the box of the trial you think will produce the tallest smear. If you think all trials will produce the same sized smear, you will write ‘same’ over all boxes. Once finished, you can raise your hands and you will receive your experimental supplies from your volunteer.”

Tell students, “When you record your data, you will make two measurements: the smear height and the liquid height. In addition, you will record any other observations, such as the colors that are observed.” Show students where they will record these three things on the results table.

Tell students, “Once you have collected your data, you will display your measurements on a graph.” Show them how to make a graph using the example data, but make sure they **do not** copy this data into their notebooks; they will graph their own data. Take out the example results table (picture packet, page 2; below, left) and put it under the document camera. Also, have the class notebook open to page 8. Tell students, “For this example experiment, the question was, ‘If we change the pen color and the liquid type, what will happen to the height of the smear?’” Point to the checklist at the top of page 8 of the class notebook and tell students, “In order to make a graph, you will need to follow the checklist at the top of this page.”

Go through the checklist, and use the results table in the picture packet, to show students how to set up the graph and plot the data points. For the example, only plot the first two data points.

Set up your graph. (Check off the steps as you complete them.)

Tell students, "First, we need to set up the graph, before we can plot the data."

- Label the y-axis (vertical) with what you measured, including units (Ex: Smear Height (cm)).*

Tell students, "Since the question is about smear height, I will graph smear height." Write "smear height (cm)" on the y-axis of the graph.

Note: When students do their actual experiment, if none of the dots smear, they can go back and modify their question to be "...what will happen to the liquid height," then plot liquid height instead of smear height.

- Determine an appropriate scale which will allow you to graph all of your data points and write the numbers on the given lines.*

Tell students, "We need to make sure the tallest smear can be plotted on the graph."

Have students refer to the results table in the picture packet and ask them to identify the tallest smear that was measured (7.5 cm). Then ask, "Would we be able to fit this smear height on the graph if we counted by ones?" Students should reply, "Yes." When students make their own graphs, they should only count by halves, ones, or twos. Number the y-axis, making sure students know to start counting at zero. Completely number the y-axis to the top; do not stop numbering after you have passed the largest number you will graph. For example, with a maximum smear height of 7.5 cm, you would number all the way to 10 cm.

- Label the x-axis (horizontal) with your changing variable(s) #1, #2, and #3 (Ex: Liquid Type). Changing variable #2 and #3 will only be filled in if you have 2 or 3 changing variables.*

Ask students, "What are the changing variables in this experiment?" Students should reply, "Liquid type and pen color." Record "Liquid Type" as changing variable #1, and "Pen Color" as changing variable #2.

- On your results table, label your measurements from 1 to 4, with 1 being the trial with the smallest measurement, and 4 being the trial with the largest measurement.*

Tell students, "Graphs are used to see how changing variables affect a measurement. One way to make it easier to find patterns is to graph the data in increasing order." Put the example results table (picture packet, page 2; below, left) under the document camera, and have students help determine the order in which the trials will be graphed (B, D, A then C). Write the appropriate number by each trial. This is the step that both students and volunteers often forget, so emphasize its importance when completing it with the class.

Plot your data in increasing order.

Tell students, "Now that you have determined the order in which you will graph your data, you need to plot your data in increasing order. To do this, there are a few steps you need to follow."

- Write the changing variable value(s) (Ex: soap) for the trial that you labeled 1 under the first column.*

Ask students, "Which trial was labeled 1?" Students should reply, "Trial B." Then, ask them, "What should I write next to liquid type and pen color for the first column?" Write "soap" for liquid type and "blue" for pen color in the class notebook.

- Graph your data for that trial and write the measurement above the bar.

Ask students, "What smear height should we graph for the first column?" Students should reply, "0 cm." Put your finger at zero, and tell students, "Tell me when to stop once I reach the appropriate level." Once you have reached the level, draw the line, write the numerical value over the line, and quickly shade below the line. Tell students, "Look how quickly I filled in the column. I challenge you to fill your graph in faster than I did, when you graph your own data."

- Repeat the process for the other trials.

Ask students, "What are the values of the changing variables for the trial we will graph next?" Students should reply, "Vinegar for liquid type, and yellow for pen color." Write these in the next column. Ask students, "What is the smear height for this trial?" Students should reply, "7 cm." Have students help you identify 7 cm on the graph, then, draw a line, and write the numerical value over the line. Tell students, "I will only graph the first two data points, but in your subgroups, you will graph all four points."

RESULTS Table

Fill out the table for each of your trials. For the variables that remain constant, write the value in trial A. Then, draw an arrow through each box indicating that this variable is a control.

Variables	Trial A	Trial B	Trial C	Trial D
Container:	Test Tube			
Time:	5 min			
Liquid Type:	RA	Soap	Water	Vinegar
Liquid Amount:	2 mL			
Paper Type:	Original			
Pen Color:	Red	Blue	Light Green	Yellow
Pen Type:	Mr. Sketch			
Initial Dot Height:	2 cm			
Cap Placement:	On			
Predictions	Trial A	Trial B	Trial C	Trial D
	T		S	
Data	Trial A ³	Trial B ¹	Trial C ⁴	Trial D ²
Smear Height:	7.5 cm	0 cm	7.5 cm	7 cm
Liquid Height:	9.5 cm	2 cm	9.5 cm	9 cm
Other:	Pink, Red	Liquid did not reach dot	Yellow	Blue, Green, Yellow

Put a "T" in the trial that will give the tallest smear and an "S" in the trial that will give the shortest smear.

RESULTS Graph

Set up your graph. (Check off the steps as you complete them.)

- Label the y-axis (vertical) with what you measured, including units (Ex: Smear Height (cm)).
- Determine an appropriate scale which will allow you to graph all of your data points and write the numbers on the given lines.
- Label the x-axis (horizontal) with your changing variable(s) #1, #2, and #3 (Ex: Liquid Type). Changing variable #2 and #3 will only be filled in if you have 2 or 3 changing variables.
- On your results table, label your measurements from 1 to 4, with 1 being the trial with the smallest measurement, and 4 being the trial with the largest measurement.

Plot your data in increasing order.

- Write the changing variable value(s) (Ex: Soap) for the trial that you labeled 1 under the first column.
- Graph your data for that trial and write the measurement above the bar.
- Repeat the process for the other trials.

Liquid Type: Soap Vinegar
Changing Variable #1
Pen Color: Blue Yellow
Changing Variable #2
: _____
Changing Variable #3

Picture Packet, Page 2

Tell students, "To keep track of which test tube corresponds to which trial, you should use a blue, wet erase pen, and write directly onto the top portion of the test tube." Show students what the wet eraser pen looks like and how to label a trial letter directly onto the top portion of a test tube, as seen in the picture on the right. Tell students, "This is the only pen you should be writing on the test tube with."

Tell students, "You will now fill out your results tables and start your experiments. When you are done with your experiments, you can graph your results."

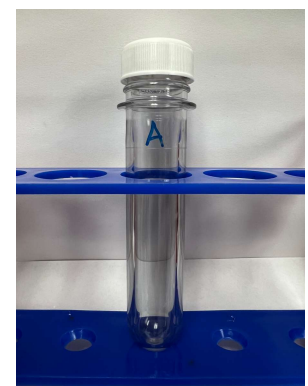

Results Table:

(3 minutes – Subgroups – SciTrek Volunteers)

Have students underline the variables that are controls, circle the variable(s) that is/are their changing variable(s), and box information about data collection. When writing the values make sure for controls, they only write the value of the control in the *Trial A* box, then, draw an arrow through the remaining trials' boxes. For the changing variable(s), they should write the values in each trial's corresponding box.

When students have finished, have them make predictions about the smears. Have them write an "S" in the box of the trial they think will produce the smallest smear and a "T" in the box of the trial they think will produce the tallest smear. They will leave two of the boxes empty. If they think all trials will produce the same smear height, have them write "same" over all of the boxes. It is okay if the students in a subgroup have different predictions. An example filled-out results table is shown in the Experiment Section below (left).

Experiment:

(17 minutes – Subgroups – SciTrek Volunteers)

Once subgroups have finished their results tables, give them their requested materials. If students are missing any of their experimental materials, the lead box has extra materials. Students should label each of their test tubes with the trial letters (A, B, C, and D) using a blue, wet erase pen. In addition, make sure students draw their initial dot height line and label their strips (A, B, C, and D) using a pencil, not a pen, so they can tell them apart later. As soon as students are done with their liquids, remove the liquids, graduated cylinders, and droppers, and put them in the bucket (please do not put trash in the bucket). It is important to do this as soon as possible so students do not play with, or spill, their liquids. When the experiment is finished, place all test tubes and caps in the bucket and put the test tube stand, timer, and pens, in your group box. Once students have finished their experiments, they can record their findings. Make sure subgroups trace the liquid line (with pencil) onto their strips so they can easily see/measure it later, if needed. Once students have finished their measurements, have them place their strips in a safe place so they can attach them to their notebook at the end of the day. If your group has things under control, help other subgroups. As soon as subgroups finish their experiments, they can graph their results. An example filled-out results table is shown below (left).

RESULTS Table

Fill out the table for each of your trials. For the variables that remain constant, write the value in trial A and then draw an arrow through each box indicating that this variable is a control.

Variables	Trial A	Trial B	Trial C	Trial D
Container:	Test Tube			
Time:	5 min			
Liquid Type:	RA	Vinegar	Water	Soap
Liquid Amount:	5 mL			
Paper Type:	Original			
Pen Color:	Black			
Pen Type:	Mr. Sketch	Expo	Bic	Dry Erase
Initial Dot Height:	1 cm	7 cm	3 cm	5 cm
Cap Placement:	On			
Predictions	Trial A	Trial B	Trial C	Trial D
	T		S	
Data	Trial A	Trial B	Trial C	Trial D
	4	3	1	2
Smear Height:	8 cm	0.5 cm	0 cm	0 cm
Liquid Height:	8 cm	7.5 cm	8 cm	2 cm
Other:	Smear went down and up black in liquid black, pink, purple	Yellow, red, blue, purple	Dot did not move	Liquid did not reach dot

The independent variable(s) is(are) the changing variable(s) and the dependent variables are the final measurements/observations.

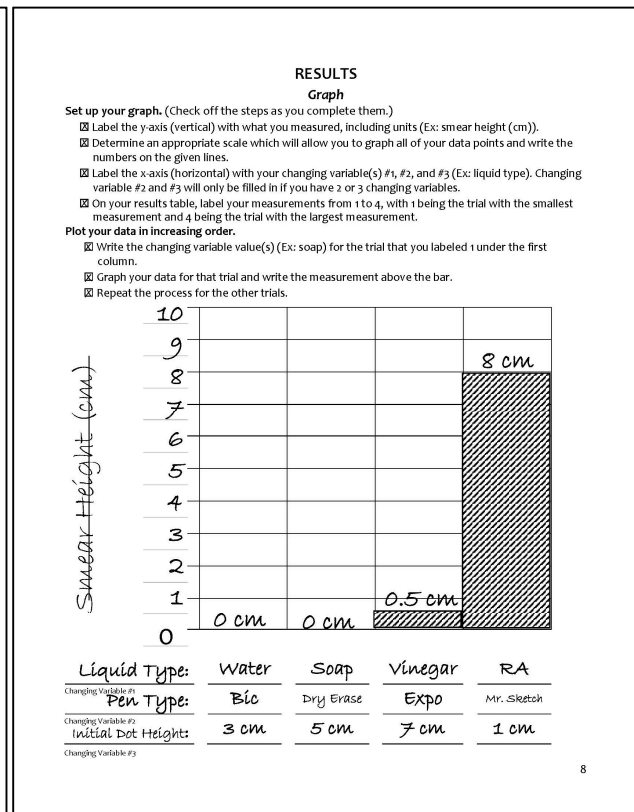

Graph:

(10 minutes – Subgroups – SciTrek Volunteers)

Help subgroups fill out their graphs by having them complete the checklist on the top of page 8. Be sure students label the y-axis with “Smear Height (cm)” (or “Liquid Height (cm),” if needed) and the x-axis with all of their changing variable(s). If students pick systems in which the dot did not smear, they can go back to page 4 and revise their question from “...what will happen to the height of the smear?” to “...what will happen to the height of the liquid?” Students will need to decide what scale to use on the y-axis. Students can use halves, ones, or twos. Step 4 of the graphing checklist has students label their measurements in increasing order (1-4) on their results table to ensure that they are graphed in increasing order, as seen in the example above. This makes it easier for the students to see trends in their data. In the example above, the trials were graphed in the following order: C, D, B, A. Once students have graphed their values, make sure they write the numerical value of the smear or liquid height on top of each column, so it is easy to quickly read the graph. An example filled-out graph is shown above (right).

If students finish early, they can start working on the conclusion activity on page 9 of their notebooks by themselves.

Note: It is okay if students do not complete their graph by the time the lead starts the conclusion activity. **Do not** have students go back and finish their graph (even if they only changed one variable). Students who do not finish their first graph will present their second experiment and, therefore, will not need their first graph.

Conclusion Activity:

(20 minutes – Full Class – SciTrek Lead)

Note: Even if all students are not finished with their graphs, it is important to start the conclusion activity at least 15 minutes before the end of the session.

Have students turn to page 9 in their notebooks while you turn to page 9 in the class notebook displaying, it under the document camera. Tell students, “Before you analyze your results and draw a conclusion, it is important that you recognize and understand other scientists’ conclusions.”

Ask the class, “What is a conclusion?” After listening to the students’ answers, make sure they understand a conclusion is a **claim supported by data**. Write this definition on page 9 of the class notebook for students to copy.

Tell students, “In order to make a conclusion, we need to make sure we understand the difference between a claim and data.” First, read the definition of a claim, then, read the example. Ask students, “Can you test the statement cats, on average, weigh less than dogs?” Students should reply, “Yes.” Tell students, “Because you can test this statement it is a claim.” Have two students suggest possible claims. For each suggested claim ask the class, “Can this statement be verified by testing?” Have students hold their thumb up if it can, making it a claim, and down if it cannot. Several examples are shown below.

Examples: rabbits are faster than mice
 giraffes are taller than horses
 watermelons weigh more than pumpkins

Next, read the definition of data and the example. The example data supports the example claim, therefore, by combining the two statements, a conclusion can be formed. This conclusion would be: Cats, on average, weigh less than dogs, because the average weight of a dog is 14 kg, and the average weight of a cat is 5 kg. Tell students, “Data often contains a numerical measurement such as a height (5 m), or a mass (20 kg). When you see data in a statement, you should box it.” Have students identify, and then box, the data in the statement (14 kg and 5 kg). Ask students, “Does data have to contain a numerical measurement?” By the end of the conversation, make sure students understand data can also exist in the form of observations. Tell students, “When a statement contains observational data, the statement will say things like ‘we observed,’ ‘we recorded,’ or something else to let you know the experiment was carried out.” If desired you can point out that animal type was the changing variable and circle cats and dogs.

Ask students, “Are all statements either a claim or data?” Lead students to realize some statements are neither a claim nor data. A common example of a statement that is not a claim or data is an opinion statement. Have students generate an example of an opinion statement.

Ex: Rabbits are cuter than cats.

Read the directions to part 2 aloud to the class. Tell students, “You will look for clues in the statements to identify whether it is a claim, data, or opinion.” For each statement, read it aloud to students and give students approximately 15 seconds to circle the answer. Then, have a student share what they think the correct answer is and why. Have students vote using thumbs up/thumbs down if they agree/disagree with the student’s reasoning. After the class has come to a consensus, tell students, “We will now box the correct answer. But we will not erase our original answer because scientists like to see which concepts/categories they are struggling with.” Mark the correct answer on the class notebook for students to copy. If the statement is a claim, have the students state the data they would need to collect

in order to make a conclusion. If the statement is data, have the students generate a claim that could be supported by that data.

For each statement, underline any controls, box any information that is data, and double underline any opinions.

SCIENTIFIC PRACTICES
Conclusions

1. **Directions:** Fill in the missing definition.

- **Conclusion:** a claim supported by data
 - **Claim:** A statement that can be tested. The explanation of the data, the first part of a conclusion.
 - Ex: Cats, on average, weigh less than dogs
 - **Data:** Evidence collected from experiment(s) (measurements or observations), the second part of a conclusion.
 - Ex: the average weight of a dolphin is 14 kg, and the average weight of a cat is 5 kg.

2. **Directions:** Circle if the statement is a CLAIM, DATA, or an OPINION.

a. McDonald's served 100 customers and Taco Bell served 75 customers Claim Data Opinion

b. blue is the best color Claim Data Opinion

c. butterflies that are larger than 15 cm, are attracted to bright colors Claim Data Opinion

d. ice was observed floating on water Claim Data Opinion

e. people buy more pizza than hamburgers Claim Data Opinion

f. the average male blue whale weighs 91,000 kg, while the average female blue whale weighs 122,000 kg Claim Data Opinion

g. the tastier the fruit, the more bugs on the fruit Claim Data Opinion

Circles are your initial thoughts and boxes are the correct answer.

9

Below are the explanations and answers to part 2, letters a-g, on page 9.

a. McDonalds served 100 customers, and Taco Bell served 75 customers

What type of statement is this, and how do you know?

Data, because it contains a measurement

What claim could be paired with this statement to make a conclusion?

McDonalds serves more customers than Taco Bell

b. blue is the best color

What type of statement is this, and how do you know?

Opinion, because it contains the word best

c. butterflies that are larger than 15 cm, are attracted to bright colors

What type of statement is this, and how do you know?

Claim, because this is something that you can test

What data would you need to obtain to support the claim?

Count the number of butterflies that are larger than 15 cm that land on a brightly colored paper and compare that with the number of butterflies that land on black or brown paper

Are the numbers in this statement a measurement from the experiment?

No, the numbers are describing the experiment and are called descriptive numbers. Tell students, “Descriptive numbers are controls because they are values that are the same for all trials.” Write “descriptive number” above *15 cm*.

d. *ice was observed floating on water*

What type of statement is this, and how do you know?

Data, because it contains an observation

What claim could be paired with this statement to make a conclusion?

Ice is less dense than water

e. *people buy more pizza than hamburgers*

What type of statement is this, and how do you know?

Claim, because it can be tested

What data would you need to obtain to support the claim?

Count the number of people that buy pizza and hamburgers in one day

f. *the average male blue whale weighs 91,000 kg, while the average female blue whale weighs 122,000 kg*

What type of statement is this, and how do you know?

Data, because it contains a measurement

What claim could be paired with this statement to make a conclusion?

Female blue whales weigh more than male blue whales

g. *the tastier the fruit, the more bugs on the fruit*

What type of statement is this, and how do you know?

Opinion, because it contains the word tastier

Have students turn to page 10 in their notebooks. While you put the same page of the class notebook under the document camera.

Tell students, “You are now going to try matching claims with supporting data. Be sure to read the statements carefully, because not all of the claims will make a match. Only draw lines between the claims that match up with supporting data.” Allow students approximately 2 minutes to work by themselves, then go over the answers as a class.

Ask the class, “Has anyone identified a match?” Then, have them give you the number and the letter of the possible match. Read each suggested claim/data match and have the rest of the class show whether they agree/disagree using thumbs up/thumbs down. If they disagree, ask a student to explain. Continue asking students if they are able to make any other connections until all possible matches are made.

SCIENTIFIC PRACTICES
Conclusions

3. **Directions:** Draw a line connecting claims with the correct data. If there is no data that supports the claim, do not draw a line.

Claim	because	Data
1. People read more from electronic devices than books	/	a. Sony TVs give off <u>20 lumens</u> of light and Samsung TVs give off <u>10 lumens</u> of light.
2. Sony TVs are brighter than Samsung TVs	/	b. when blue and red paint were mixed the paint was <u>observed</u> to turn purple.
3. The color purple is made from blue and red	/	c. wind turbines produce 6,000 MW of energy and solar panels produce 5,000 MW of energy in California.
4. Wind turbines produce less energy than solar panels in California	/	d. the speed of light is measured to be $3 \times 10^8 \frac{m}{s}$.

10

Below are correct matches that can be made from this activity.

1. Sony TVs are brighter than Samsung TVs, because Sony TVs give off 20 lumens of light and Samsung TVs give off 10 lumens of light.
This is a correct match, because the data clearly supports the claim using numerical values as data to make a conclusion.

2. The color purple is made from blue and red, because when blue and red paint were mixed, the paint was observed to turn purple.
This is a correct match, because the data clearly supports the claim, using an observation to make a conclusion.

Below are incorrect matches that can be made from this activity.

1. Wind turbines produced less energy than solar panels in California, because wind turbines produce 6,000 MW of energy and solar panels produce 5,000 MW of energy in California.
This is an incorrect match, because the data does not support the claim. The claim says less energy is produced by wind turbines, however, the data supports the opposite claim, solar panels produce less energy. Ask students, "In order to make a conclusion, do you think scientists can change the claim or the data?" Students should realize that scientists can change their claims, but they cannot change their data. In addition, scientists must include all data when generating a claim.

2. More people read from electronic devices than books, because the speed of light is measured to be $3 \times 10^8 \frac{m}{s}$.
This is an incorrect match because the data has nothing to do with the claim, and thus does not support it. Therefore, this is an incorrect conclusion.

If there is additional time, you can continue on to the next page of the conclusion activity. For details on how to do this see Day 4.

Wrap-Up:

(2 minutes – Full Class – SciTrek Lead)

Tell students, “Next session, you will analyze other scientists’ data to identify appropriate claims and data statements. You will then analyze your own data, and either write a conclusion for your experiment or determine why you cannot draw a conclusion. Afterwards, you will get to design a second experiment.”

Clean-Up:

1. Collect notebooks with attached nametags.
2. Put all liquid and dishes into the bucket.
3. Place all other materials into your group box and bring them back to UCSB.

Day 4: Conclusion Activity/Conclusion/Question/Materials Page/Experimental Set-Up/Procedure

Schedule:

Introduction (SciTrek Lead) – 2 minutes
 Conclusion Activity (SciTrek Lead) – 25 minutes
 Conclusion (SciTrek Volunteers) – 5 minutes
 Question (SciTrek Volunteers) – 5 minutes
 Materials Page (SciTrek Volunteers) – 5 minutes
 Experimental Set-Up (SciTrek Volunteers) – 5 minutes
 Procedure (SciTrek Volunteers) – 11 minutes
 Wrap-Up (SciTrek Lead) – 2 minutes

Materials:

(3) Volunteer Boxes:

- | | | |
|---|--|--|
| <input type="checkbox"/> Nametags | <input type="checkbox"/> Volunteer lab coat | <input type="checkbox"/> (2) Pencils |
| <input type="checkbox"/> Notebooks | <input type="checkbox"/> (3) Materials pages (subgroup color/number indicated) | <input type="checkbox"/> (2) Red pens |
| <input type="checkbox"/> Volunteer instructions | | <input type="checkbox"/> Paper notepad |

Lead Box:

- | | | |
|--|--|--|
| <input type="checkbox"/> (3) Extra notebooks | <input type="checkbox"/> Lead lab coat | <input type="checkbox"/> (2) Red pens |
| <input type="checkbox"/> Lead instructions | <input type="checkbox"/> (3) Materials pages | <input type="checkbox"/> (2) Wet erase markers |
| <input type="checkbox"/> Chromatography picture packet | <input type="checkbox"/> Time card | <input type="checkbox"/> (2) Black pens |
| | <input type="checkbox"/> (2) Pencils | <input type="checkbox"/> Paper notepad |

Notebook Pages:

SCIENTIFIC PRACTICES Conclusions

Variables	Trial A	Trial B
Time:	5 min	→
Liquid Type:	Water	→
Liquid Amount:	2 ml	→
Paper Type:	Original	→
Pen Color:	Black	→
Pen Type:	Mr. Sketch	Crayola
Initial Dot Height:	2 cm	→
Data	Trial A	Trial B
Smear Height:	3 cm	2 cm
Liquid Height:	5 cm	4 cm
Other:	Green Blue Red	Yellow Blue Red

4. Directions: **Step 1:** Identify the following statements as either CLAIM or DATA and write a C or D on the line. **Step 2:** Look at the results table and circle if the statement is a correct claim, correct data, or incorrect. Statements are INCORRECT if the statement does not agree with the data table or has not been tested.

	Step 1: Statement Type: C or D	Step 2: Based on the table, is the statement a correct claim, correct data, or incorrect?
--	--	---

a. the paper type affects the height the liquid travels up the paper. C Correct Claim Correct Data Incorrect

b. black pen types are made up of different dye colors. C Correct Claim Correct Data Incorrect

c. when a black dot sits in water for 5 min, different pen types give different smear heights. C Correct Claim Correct Data Incorrect

d. the black Crayola was observed to contain green dye. D Correct Claim Correct Data Incorrect

What data can be used to support claim b above? Black Mr. Sketch was observed to contain green, blue, and red dyes while black Crayola was observed to contain yellow, blue, and red dyes.

SCIENTIFIC PRACTICES Conclusions

Variables	Trial A	Trial B
Time:	5 min	4 min
Liquid Type:	Water	Soap
Liquid Amount:	2 ml	→
Paper Type:	Original	→
Pen Color:	Black	Red
Pen Type:	Mr. Sketch	→
Initial Dot Height:	2 cm	→
Data	Trial A	Trial B
Smear Height:	3 cm	1.5 cm
Liquid Height:	5 cm	3.5 cm
Other:	Green Blue Red	Red Orange

5. **Step 1:** Statement Type: C or D **Step 2:** Based on the table, is the statement a correct claim, correct data, or incorrect?

a. the stronger the pen odor, the larger the smear height. C Correct Claim Correct Data Incorrect

b. the black pen had a smear height of 3 cm and the red pen had a smear height of 1.5 cm. D Correct Claim Correct Data Incorrect

c. black and red pens are made from green dye. C Correct Claim Correct Data Incorrect

d. the thicker the liquid, the shorter the smear height. C Correct Claim Correct Data Incorrect

If no claim can be made from the data state why not. No claim can be made because there is more than one changing variable.

If no claim can be made from the results, can you make a conclusion? YES NO

SCIENTIFIC PRACTICES Conclusions

6. Directions: Decide if a claim/conclusion can be made for each of the following results tables and graph.

Table A

Variables	Trial A	Trial B
Time:	3 min	2 min
Pen Type:	Crayola	Mr. Sketch
Pen Color:	Black	→
Paper Type:	Original	→
Liquid:	Water	→
Liquid Amount:	2 ml	4 ml
Data	Trial A	Trial B
Smear Height:	3 cm	4 cm

Table B

Variables	Trial A	Trial B
Time:	5 min	→
Pen Type:	Mr. Sketch	→
Pen Color:	Blue	→
Paper Type:	Newspaper	Original
Liquid:	Vinegar	→
Liquid Amount:	5 ml	→
Data	Trial A	Trial B
Smear Height:	3.5 cm	4 cm

Can this scientist make a claim/conclusion? No Can this scientist make a claim/conclusion? Yes

Table C

Variables	Trial A	Trial B
Time:	5 min	→
Pen Type:	Rose Art	Expo
Pen Color:	Black	→
Paper Type:	Original	→
Liquid:	Soap	→
Liquid Amount:	2 ml	→
Data	Trial A	Trial B
Smear Height:	3 cm	3 cm

Graph D

Can this scientist make a claim/conclusion? Yes Can this scientist make a claim/conclusion? No

Making a Conclusion from Your Data

How many changing variables did you have in your experiment? 3

Can you make a conclusion from your data? YES NO

IF NO

Why? I cannot make a conclusion because my experiment had more than one changing variable.

IF YES

CONCLUSION

We can conclude _____ claim

because _____ data (measurement/observation)

SciTrek Member Approval DF

Changing Variable(s) (Independent Variable(s))

For your second experiment, decide which variable(s) (max three) you would like to test.

Changing Variable 1: Pen Color

Changing Variable 2 (optional): _____

Changing Variable 3 (optional): _____

QUESTION

Question our subgroup will investigate:

- If we change the pen color insert each changing variable (independent variable), what will happen to the height and color of the smear insert what you are measuring/observing (dependent variable)?

SciTrek Member Approval: DF

Get a materials page from your volunteer and fill it out before moving onto the experimental set-up.

15

EXPERIMENTAL SET-UP

Write your changing variable(s) (Ex: pen color) and the values (Ex: blue) you will use for your trials under each strip of paper.

E

F

G

H

Changing Variable(s):

1) Pen Color: Purple Light Green Orange Black

2) _____:

3) _____:

Controls (variables you will hold constant):
Write your controls and the values you will use in all your trials (control/value, Ex: container/test tube).

Container /	Test Tube	Pen Type /	Mr. Sketch
Liquid Type /	Water	Time /	4.5 min
Liquid Amount /	5 mL	Paper Type /	Original
Cap Placement /	On	Initial Dot /	2 cm Height

SciTrek Member Approval: DF

16

PROCEDURE

Procedure Note:
Make sure to include all values of your changing variable(s) in the procedure (Ex: For a subgroup that decided to change pen color, one step would be: Put colored dot with Mr. Sketch pens E) red, F) blue, G) green, and H) yellow on original paper at 2 cm.)

- Fill 4 test tubes with 5 mL of water.
- Draw dots at 2 cm on original papers with a E) purple, F) light green, G) orange, and H) black Mr. Sketch.
- Put papers in test tubes and put caps on.
- Wait for 4.5 minutes.
- Remove papers.
- Measure smear heights and observe smear colors.

SciTrek Member Approval: DF

17

Preparation:

SciTrek Lead:

1. Make sure volunteers are passing out notebooks.
2. Set up the document camera for the conclusion activity (notebook, pages 11- 13).

SciTrek Volunteers:

1. Pass out notebooks/nametags.
2. Make sure you have three materials pages, each filled out with a subgroup number (1, 2, or 3) and your group's color to give to subgroups after they complete their question.
3. Have a red pen available to approve subgroups' conclusions, questions, experimental set-ups, and procedures (notebook, pages 14-17).

Note: Pass out notebooks to students. If needed, students will move to their subgroups after the conclusion activity.

Introduction:

(2 minutes – Full Class – SciTrek Lead)

If students are not in their subgroups, tell students, "You will move to your subgroups after the conclusion activity."

Tell students, "Today, you are going to analyze scientists' data to determine which claims and data are appropriate for a given set of results. Afterwards, you will analyze your own data to see if you can make a claim/conclusion. You will then have the opportunity to design a second experiment or redesign your first experiment, which will be carried out during the next visit."

Conclusion Activity:

(25 minutes – Full Class – SciTrek Lead)

Have students turn to page 11 in their notebooks. Place the class notebook under the document camera and turn to page 11.

Ask students, "What is the definition of a conclusion?" Students should reply, "A claim supported by data." Ask students, "What is the definition of a claim?" Students should reply, "A statement that can be tested." Ask students, "What type of information can be used for data?" Students should reply: "Measurements or observations."

Have students annotate the results table. As a group, identify then underline the controls (*time, liquid type, liquid amount, paper type, pen color, and initial dot height*), circle the changing variable (*pen type*), and box the information about the data collected (*smear height, liquid height, and other*).

Tell students, "We are now going to look over a list of statements about this results table and decide whether each statement is an example of a claim or data. If the statement is a claim, we will identify and circle the changing variable, if the statement is data, we will box the data. We will then use the results table to determine whether the statement is a correct claim, correct data, or incorrect."

First, read the statement and have students classify the statement as claim, C, or data, D, and write the corresponding letter on the line. Second, have students help you annotate the statement by underlining controls, circling the changing variable (every claim statement will have a changing variable), and boxing any data. Third, have students check the results table to determine whether the statement is a correct

claim, correct data, or incorrect, and circle the appropriate answer. Repeat this process for each statement.

If students are struggling to identify the changing variable, ask them, “What experiment would we need to carry out to test this claim?” From their answer, have them identify what they changed.

a. the paper type affects the height the liquid travels up the paper

What type of statement is this and how do you know?

Claim, because it can be tested (write “C” on the line)

What would need to be the changing variable for this claim to be correct?

Paper type (circle *paper type*)

Is paper type a changing variable in this experiment?

No

What should we circle?

Incorrect

b. black pen types are made up of different dye colors

What type of statement is this and how do you know?

Claim, because it can be tested (write “C” on the line)

What would need to be the changing variable for this claim to be correct?

Pen type (circle *pen type*)

Is pen type a changing variable in this experiment?

Yes

Is the claim consistent with the data?

Yes

What should we circle?

Correct claim

c. when a black dot sits in water for 5 min, different pen types give different smear heights

What type of statement is this and how do you know?

Claim, because it can be tested (write “C” on the line)

What would need to be the changing variable for this claim to be correct?

Pen type (circle *pen type*)

Is the 5 minutes data?

No, it is a descriptive number (one of the controls; underline *5 min*)

Are there any other controls in this statement?

Black (underline *black*)

Is pen type a changing variable in this experiment?

Yes

Is the claim consistent with the data?

Yes

What should we circle?

Correct claim

d: the black Crayola was observed to contain green dye

What type of statement is this, and how do you know?

Data, because it contains an observation (write "D" on the line and box *green dye*)

What is black Crayola?

Black is a control and Crayola is a changing variable (underline *black* and circle *Crayola*)

Is the data correct based on the results table?

No

What should we circle?

Incorrect

Tell students, "We are now going to determine the data to support claim b." Read claim *b* aloud (*black pen types are made up of different dye colors*) and ask students, "What data can be used to support this claim?" Possible student response: black Mr. Sketch was observed to contain green, blue, and red dyes, while black Crayola contained yellow, blue, and red dyes. Record this statement in the class notebook. Ask students, "How would people know that the statement generated was data?" Possible student response: the statement contains observations. In the statement, underline the word *black* (two times), box the words *green, blue, and red dyes* and *yellow, blue, and red dyes* and circle the words *Mr. Sketch* and *Crayola*. Then, read the complete conclusion: black pen types are made up of different dye colors because black Mr. Sketch was observed to contain green, blue, and red dyes while black Crayola contained yellow, blue, and red dyes.

SCIENTIFIC PRACTICES
Conclusions

	Trial A	Trial B
Variables		
<u>Time:</u>	5 min	→
<u>Liquid Type:</u>	Water	→
<u>Liquid Amount:</u>	2 ml	→
<u>Paper Type:</u>	Original	→
<u>Pen Color:</u>	Black	→
<u>Pen Type:</u>	Mr. Sketch	Crayola
<u>Initial Dot Height:</u>	2 cm	→
Data	Trial A	Trial B
Smear Height:	3 cm	2 cm
Liquid Height:	5 cm	4 cm
Other:	Green Blue Red	Yellow Blue Red

4. Directions **Step 1:** Identify the following statements as either CLAIM or DATA and write a C or D on the line. **Step 2:** Look at the results table and circle if the statement is a correct claim, correct data, or incorrect. Statements are INCORRECT if the statement does not agree with the data table or has not been tested.

	Step 1: Statement Type: C or D		Step 2: Based on the table, is the statement a correct claim, correct data, or incorrect?	
a. the <u>paper type</u> affects the height the liquid travels up the paper	C	Correct Claim	Correct Data	Incorrect
b. <u>black pen types</u> are made up of different dye colors	C	Correct Claim	Correct Data	Incorrect
c. when a <u>black dot sits in water</u> for <u>5 min</u> , different <u>pen types</u> give different smear heights	C	Correct Claim	Correct Data	Incorrect
d. the <u>black Crayola</u> was observed to contain <u>green</u> dye	D	Correct Claim	Correct Data	Incorrect

What data can be used to support claim b above? Black Mr. Sketch was observed to contain green, blue, and red dyes while black Crayola was observed to contain yellow, blue, and red dyes.

11

Have students turn to page 12 in their notebooks while you do the same in the class notebook.

Have students annotate the results table. As a group, identify and underline the controls (*Liquid Amount*, *Paper Type*, *Pen Type*, and *Initial Dot Height*), circle the changing variables (*Time*, *Liquid Type*, and *Pen Color*), and box the information about the data collected (*Smear Height*, *Liquid Height*, and *Other*).

Tell students, “We are now going to go through the same process that we went through for the statements about the last results table.”

a. *the stronger the pen odor, the larger the smear height*

What type of statement is this and how do you know?

Claim, because it can be tested (write “C” on the line)

What would need to be the changing variable for this claim to be correct?

Pen odor (circle *pen odor*)

Is pen odor a changing variable in this experiment?

No

What should we circle?

Incorrect

b: *the black pen had a smear height of 3 cm, and the red pen had a smear height of 1.5 cm*

What type of statement is this and how do you know?

Data, because it contains measurements (write “D” on the line, and box *3 cm* and *1.5 cm*)

What are black and red?

Black and red are both changing variables (circle *black* and *red*)

Is the data correct based on the data table?

Yes

What should we circle?

Correct data

c. *black and red pens are made from green dye*

What type of statement is this and how do you know?

Claim, because it can be tested (write “C” on the line)

What would need to be the changing variable for this claim to be correct?

Pen color (circle *black and red pens* and write “pen color” over the statement)

Is pen color a changing variable in this experiment?

Yes

Is the claim consistent with the data?

No

What should we circle?

Incorrect

d: *the thicker the liquid, the shorter the smear height*

What type of statement is this and how do you know?

Claim, because it can be tested (write “C” on the line)

What would need to be the changing variable for this claim to be correct?

Liquid type (circle *thicker the liquid* and write “liquid type” above the statement)

Is liquid type a changing variable in this experiment?

Yes

Is the claim consistent with the data?

Yes

Is this claim fair, or could the smear height be changing because of another reason?

This claim is not fair, because the smear height could have changed as a result of changing the time, or the pen color

What should we circle?

Incorrect

Ask students, “Why can’t a claim be made from the data?” Possible student response: there is more than one changing variable, so you cannot tell which variable affected the results, or how/why these changing

variables affected the smear. Record this answer on the class notebook and have students copy this into their notebooks.

Ask students, "Do you think a conclusion can be made from the data if a claim cannot be made?" Possible student response: since a conclusion is defined as a claim supported by data, you would need both a claim and data to make a conclusion. Since no claims can be made, a conclusion cannot be made either. Have students check the **NO** box in their notebook.

SCIENTIFIC PRACTICES
Conclusions

Variables	Trial A	Trial B
Time:	5 min	4 min
Liquid Type:	Water	Soap
Liquid Amount:	2 ml	
Paper Type:	Original	
Pen Color:	Black	Red
Pen Type:	Mr. Sketch	
Initial Dot Height:	2 cm	
Data	Trial A	Trial B
Smear Height:	3 cm	1.5 cm
Liquid Height:	5 cm	3.5 cm
Other:	Green Blue Red	Red Orange

5. Step 1: Statement Type: C or D Step 2: Based on the table, is the statement a correct claim, correct data, or incorrect?

a. the stronger the pen odor the larger the smear height C Correct Claim Correct Data Incorrect

b. the black pen had a smear height of 3 cm and the red pen had a smear height of 1.5 cm D Correct Claim Correct Data Incorrect

c. black and red pens are made from green dye C Correct Claim Correct Data Incorrect

d. the thicker the liquid the shorter the smear height C Correct Claim Correct Data Incorrect

If no claim can be made from the data state why not. No claim can be made because there is more than one changing variable.

If no claim can be made from the results, can you make a conclusion?
 YES NO

12

Ask students, "What did you learn about conclusions from this activity?" Make sure, by the end of the conversation, students understand that in order to draw a conclusion, there must only be one changing variable in an experiment.

Tell students, "You are now going to look at three results tables and one graph to determine which data sets would allow you to make a claim/conclusion." As a class, go through each table/graph and underline controls, circle changing variable(s), and box information about data collection. It is important for this section that every student has a chance to tell you how to annotate one of the words in the results table. This will help you know who needs extra practice with reading results tables. Once the table/graph has been annotated, have students decide if that group could make a claim/conclusion before moving to the next table/graph.

SCIENTIFIC PRACTICES
Conclusions

6. Directions: Decide if a claim/conclusion can be made for each of the following results tables and graph.

Table A

Variables	Trial A	Trial B
Time	3 min	2 min
Pen Type	Crayola	Mr. Sketch
Pen Color	Black	
Paper Type	Original	
Liquid	Water	
Liquid Amount	2 ml	4 ml
Data	Trial A	Trial B
Smear Height	3 cm	4 cm

Can this scientist make a claim/conclusion? No

Table B

Variables	Trial A	Trial B
Time	5 min	
Pen Type	Mr. Sketch	
Pen Color	Blue	
Paper Type	Newspaper	Original
Liquid	Vinegar	
Liquid Amount	5 ml	
Data	Trial A	Trial B
Smear Height	3.5 cm	4 cm

Can this scientist make a claim/conclusion? Yes

Table C

Variables	Trial A	Trial B
Time	5 min	
Pen Type	Rose Art	Expo
Pen Color	Black	
Paper Type	Original	
Liquid	Soap	
Liquid Amount	2 ml	
Data	Trial A	Trial B
Smear Height	3 cm	3 cm

Can this scientist make a claim/conclusion? Yes

Graph D

Liquid Amount (ml)	Smear Height (cm)
2 ml (Red)	3 cm
4 ml (Blue)	4 cm
5 ml (Black)	5 cm
8 ml (Green)	6 cm

Can this scientist make a claim/conclusion? No

13

Once students have annotated a table or graph on page 13, ask them the following questions:

- How many changing variables are there?
- Can a claim/conclusion be made from this data?
- Why not or why not?

Tell students, “Tables (such as tables A-C) and graphs (such as graph D) represent two different ways of displaying results from an experiment.” Ask students, “Was there anything that we did not annotate in the graph?” Students should reply, “Controls.” Tell students, “Results tables show all controls, changing variables, as well as the data but it is hard to see trend in the data. Graphs show only the changing variables and data but do not show controls. However, they do make it easy to see the trends in the data. This is why scientists use both tables and graphs.”

Tell students, “You will now analyze your own data to see whether or not you can make a conclusion. It is okay if you cannot draw a conclusion from your first experiment, because you will have the opportunity to run another experiment. When you run a second experiment, you should only change one variable, allowing you to be able to draw a conclusion. Once you have decided whether you can or cannot make a conclusion, you will either use your results to make a conclusion, or state why you cannot make a conclusion from your data. After, you can move on to designing your new experiment. You are going to give poster presentations at the end of the module and the presentations will be more interesting if there are a wide range of changing variables that have been tested. In addition, if a wide range of variables are chosen, the class question (What variables affect smears?) will be more completely answered. Therefore, I challenge you to explore a changing variable that you think few other subgroups are investigating.”

Tell students, “You will start working with your subgroup to analyze your old experiment and plan your new experiment.”

Conclusion:

(5 minutes – Subgroups – SciTrek Volunteers)

Help subgroups fill out page 14 of their notebooks. If the subgroup has more than one changing variable, they will not be able to draw a conclusion. An example of a scenario in which a subgroup cannot make a conclusion, is shown below (left).

If the subgroup has only one changing variable, they will be able to make a conclusion. Make sure subgroups’ conclusions have both a claim (statement that can be tested) and supporting data (measurements and/or observations), and these statements are in the appropriately labeled sections. Conclusions are still valid and important, if they show the changing variable tested does not have an effect on the smear. Even if their conclusion is contrary to what you think, have subgroups make a claim based solely on their data. If you think their data is flawed, it is okay to ask them what they think went wrong and encourage them to repeat their experiment. An example of a scenario in which a subgroup can make a conclusion is shown below (right).

<p>Making a Conclusion from Your Data</p> <p>How many changing variables did you have in your experiment? <u>3</u></p> <p>Can you make a conclusion from your data? <input type="checkbox"/> YES <input checked="" type="checkbox"/> NO</p> <div style="border: 1px solid black; padding: 5px; margin: 5px 0;"> <p>IF NO</p> <p>Why? <u>I cannot make a conclusion because my experiment had more than one changing variable.</u></p> </div> <div style="border: 1px solid black; padding: 5px; margin: 5px 0;"> <p>IF YES</p> <p style="text-align: center;">CONCLUSION</p> <p>We can conclude _____ <small>claim</small></p> <p>because _____ <small>data (measurement/observation)</small></p> </div> <p style="text-align: right;">SciTrek Member Approval: <u>DF</u></p> <p style="text-align: right; font-size: small;">14</p>	<p style="text-align: center;">CONCLUSION</p> <p>Making a Conclusion from Your Data</p> <p>How many changing variables did you have in your experiment? <u>1</u></p> <p>Can you make a conclusion from your data? <input checked="" type="checkbox"/> YES <input type="checkbox"/> NO</p> <div style="border: 1px solid black; padding: 5px; margin: 5px 0;"> <p>IF NO</p> <p>Why? _____</p> </div> <div style="border: 1px solid black; padding: 5px; margin: 5px 0;"> <p>IF YES</p> <p style="text-align: center;">CONCLUSION</p> <p>We can conclude <u>the thicker the liquid, the smaller the smear height,</u> <small>claim</small></p> <p>because <u>the smear height in soap was 1 cm and the smear height in water was 6 cm.</u> <small>data (measurement/observation)</small></p> </div> <p style="text-align: right;">SciTrek Member Approval: <u>DF</u></p> <p style="text-align: right; font-size: small;">14</p>
--	--

Question:

(5 minutes – Subgroups – SciTrek Volunteers)

Have subgroups decide what changing variable they want to explore for their second experiment. Make sure each subgroup has only one changing variable, so they will be able to make a claim and conclusion after their experiment. Encourage your subgroups to have different changing variables. The lead will help coordinate between groups to ensure there is a variety of changing variables.

After subgroups have decided on their single changing variable, have them fill out their question. When you sign off on their question, give them a materials page with their subgroup color and number designated in the upper right-hand corner. An example filled-out question is shown below.

Changing Variable(s) (Independent Variable(s))

For your second experiment, decide which variable(s) (max three) you would like to test.

Changing Variable 1: Pen Color

Changing Variable 2 (optional): _____

Changing Variable 3 (optional): _____

QUESTION

Question our subgroup will investigate:

- If we change the pen color,
insert each changing variable (independent variable)
 what will happen to the height and color of
insert what you are measuring/observing (dependent variable)
the smear ?

SciTrek Member Approval: DF

Get a materials page from your volunteer and fill it out before moving onto the experimental set-up.

15

Materials Page:

(5 minutes – Subgroups – SciTrek Volunteers)

Have subgroups underline their controls and circle their changing variable, on the materials page. Then, have them use the materials page to choose the values for their controls and changing variable. For the changing variable values, have students write the trial letter (E, F, G, H) next to the value they select. Ask students, “Why did you choose the values you did for your controls and changing variable?, Will these values make it easier or harder to answer your question?”

Make sure students have picked liquid amounts, initial dot heights, and times, that are within the limitations given on the materials page. An example filled-out materials page is shown in the Experimental Set-Up section.

Experimental Set-Up:

(5 minutes – Subgroups – SciTrek Volunteers)

Have subgroups use their materials page to fill in their experimental set-ups (notebook, page 16). When you sign off on their experimental set-ups, ensure all students within a subgroup have the same trial letters corresponding to the same changing variable values; then, collect the materials page and verify that it is filled out correctly and completely. Filling out the materials page is essential for students to obtain the correct materials for their experiments on Day 5. An example filled-out experimental set-up is shown below (right).

Color (circle one): Orange Blue Green
 Group Number (circle one): 1 2 3

MATERIALS PAGE

You will only have access to the following materials.

- For each bolded word, underline it if it is a control and circle it if it is a changing variable. Example control: Liquid Type, Example changing variable: Pen Type
- For variables that are controls, choose 1 value.
- For variables that are changing variables, choose 4 values and write the trial letter (A,B,C,D or E,F,G,H) next to each value. Example: Crayola A

General Materials:
 4 test tubes with caps test tube rack timer
 2 rulers 2 droppers 2 graduated cylinders

Liquid Type:
 rubbing alcohol (RA) soap vinegar
 water

Liquid Amount: 5 mL
 Any amount up to 20 mL (original liquid amount = 2 mL)

Paper Type:
 original paper coffee filter copy paper paper towel
 graph paper newspaper construction paper

Pen Type:
 Mr. Sketch (original) Crayola Expo
 Sharpie Rose Art BIC (Black Only)
 Dry Erase (Black Only) Paper Mate (Black Only)

Pen Color:
 red orange G yellow green
 blue purple E black (original) H brown
 The following colors can only be chosen if your pen type is Mr. Sketch.
 light pink dark pink light blue light green F

Initial Dot Height: 2 cm
 Any height up to 11.5 cm (original dot height = 2 cm)

Time: 4.5 min
 Any time up to 5 minutes

Materials Page

EXPERIMENTAL SET-UP

Write your changing variable(s) (Ex: pen color) and the values (Ex: blue) you will use for your trials under each strip of paper.

E

F

G

H

Changing Variable(s):

- Pen Color: Purple Light Green Orange Black
- _____ :
- _____ :

Controls (variables you will hold constant):
 Write your controls and the values you will use in all your trials (control/value, Ex: container/test tube).

<u>Container</u> / <u>Test Tube</u>	<u>Pen Type</u> / <u>Mr. Sketch</u>
<u>Liquid Type</u> / <u>Water</u>	<u>Time</u> / <u>4.5 min</u>
<u>Liquid Amount</u> / <u>5 mL</u>	<u>Paper Type</u> / <u>Original</u>
<u>Cap Placement</u> / <u>On</u>	<u>Initial Dot</u> / <u>2 cm</u>
	<u>Height</u>

SciTrek Member Approval: DF

16

Procedure:
 (11 minutes – Subgroups – SciTrek Volunteers)

After each subgroup has filled out their experimental set-up, they can start on their procedure (notebook, page 17). Make sure students within the same subgroup are collaborating to write their procedure. Keep procedures as brief as possible, while still conveying the pertinent information (control values, changing variable values, and the data they will collect) about the experiment. An example step for a subgroup who had pen color as a changing variable would be, "Put colored dot with Mr. Sketch pen E) red, F) blue, G) green, and H) yellow on original paper at 2 cm." Some subgroups may struggle with writing a procedure. If they are struggling, tell them to look back at their initial procedure on page 6 of their notebooks. If they are still having trouble, you can have these subgroups dictate each step while you transcribe them onto a notepad found in your group box. Give this sheet to the students to copy into their notebooks. Once students have finished, they should raise their hands and get their procedures approved by their volunteer. An example filled-out procedure is shown below.

If subgroups have additional time, have them fill out the top part of their results tables (notebook, page 19).

PROCEDURE

Procedure Note:
 Make sure to include all values of your changing variable(s) in the procedure (Ex: For a subgroup that decided to change pen color, one step would be: Put colored dot with Mr. Sketch pens E) red, F) blue, G) green, and H) yellow on original paper at 2 cm.)

1. Fill 4 test tubes with 5 mL of water.

2. Draw dots at 2 cm on original papers with a E) purple, F) light green, G) orange, and H) black Mr. Sketch.

3. Put papers in test tubes and put caps on.

4. Wait for 4.5 minutes.

5. Remove papers.

6. Measure smear heights and observe smear colors.

SciTrek Member Approval DF

17

Wrap-Up:

(2 minutes – Full Class – SciTrek Lead)

Tell students, “Next session, you will carry out the experiments you designed.”

Clean-Up:

1. Collect notebooks with attached nametags.
2. Place materials into your group box and bring them back to UCSB.

Day 5: Results Table/Experiment/Graph/Conclusion

Schedule:

- Introduction (SciTrek Lead) – 20 minutes
- Results Table (SciTrek Volunteers) – 5 minutes
- Experiment (SciTrek Volunteers) – 20 minutes
- Graph (SciTrek Volunteers) – 5 minutes
- Conclusion (SciTrek Volunteers) – 8 minutes
- Wrap-Up (SciTrek Lead) – 2 minutes

Materials:

(3) Volunteer Boxes:

- | | | |
|---|---|--|
| <input type="checkbox"/> Nametags | <input type="checkbox"/> Paper notepad | <input type="checkbox"/> (12) Small cups (labeled with liquid types) |
| <input type="checkbox"/> Notebooks | <input type="checkbox"/> (6) Rulers | <input type="checkbox"/> Vinegar |
| <input type="checkbox"/> Volunteer instructions | <input type="checkbox"/> Paper towels | <input type="checkbox"/> Soap |
| <input type="checkbox"/> Volunteer lab coat | <input type="checkbox"/> Water | <input type="checkbox"/> Rubbing alcohol |
| <input type="checkbox"/> (3) Pencils | <input type="checkbox"/> (3) Test tube stands | |
| <input type="checkbox"/> (2) Red pens | | |
- (3) Ziploc bags (quart size), labeled (with subgroup number), with the following:
- | | | |
|--|--|--|
| <input type="checkbox"/> Wet erase pen | <input type="checkbox"/> (2) Droppers | <input type="checkbox"/> Paper towel |
| <input type="checkbox"/> (2) 10 mL Graduated cylinders | <input type="checkbox"/> Requested strips of paper | <input type="checkbox"/> Timer |
| <input type="checkbox"/> (4) Test tubs with caps | <input type="checkbox"/> Requested pens | <input type="checkbox"/> Filled-out materials page |

Other Supplies:

-
- Bucket with lid

Lead Box:

- | | | |
|--|---|---|
| <input type="checkbox"/> (3) Extra notebooks | <input type="checkbox"/> (2) Black pens | <input type="checkbox"/> Bag 1: lead chromatography supplies ((4) 10 mL graduated cylinders, (8) test tubes with caps, (8) droppers, (12) small cups (labeled with liquid types), paper towels) |
| <input type="checkbox"/> Lead instructions | <input type="checkbox"/> Paper notepad | <input type="checkbox"/> Bag 2: lead chromatography supplies (chromatography paper (minimum 30), 6 paper types (minimum 20 each), 8 different black pens, 5 sets of different colored markers) |
| <input type="checkbox"/> Chromatography picture packet | <input type="checkbox"/> (6) Rulers | |
| <input type="checkbox"/> Lead lab coat | <input type="checkbox"/> (2) Timers | |
| <input type="checkbox"/> Time card | <input type="checkbox"/> Water | |
| <input type="checkbox"/> (2) Pencils | <input type="checkbox"/> (2) Test tube stands | |
| <input type="checkbox"/> (2) Red pens | <input type="checkbox"/> Vinegar | |
| <input type="checkbox"/> (2) Wet erase markers | <input type="checkbox"/> Soap | |
| | <input type="checkbox"/> Rubbing alcohol | |

Notebook Pages:

SCIENTIFIC PRACTICES

Conclusions

Question: If we change the Paper height what will happen to the liquid height?

Variables	Trial A	Trial B	Trial C	Trial D
Container:	Test Tube			
Time:	5 min			
Liquid Type:	Water			
Liquid Amount:	2 ml			
Paper Type:	Original			
Pen Color:	Black			
Pen Type:	Mr. Sketch			
Initial Dot Height:	2 cm			
<u>Paper Height</u> :	5 cm	10 cm	15 cm	20 cm

Data	Trial A	Trial B	Trial C	Trial D
Smear Height:	3 cm	8 cm	9 cm	9 cm
Liquid Height:	5 cm	10 cm	11 cm	11 cm
Other:	blue orange red	blue orange red	blue orange red	blue orange red

Write a conclusion from the results above:

We can conclude that the liquid will reach the top of the paper if the paper is 11 cm or shorter because when the paper height was 5 cm, the liquid height was 5 cm (same as the paper height) and when the paper height was 20 cm, the liquid height was only 11 cm (not the top of the paper).

RESULTS

Table

Fill out the chart for each of your trials. For the variables that remain constant, write the value in trial E. Then, draw an arrow through each box indicating that this variable is a control.

Variables	Trial E	Trial F	Trial G	Trial H
Container:	Test Tube			
Time:	4.5 min			
Liquid Type:	Water			
Liquid Amount:	5 mL			
Paper Type:	Original			
<u>Pen Color</u> :	Purple	light green	Orange	Black
Pen Type:	Mr. Sketch			
Initial Dot Height:	2 cm			
<u>Cap Placement</u> :	On			

Predictions	Trial E	Trial F	Trial G	Trial H
	T		S	

Data	Trial E	Trial F	Trial G	Trial H
Smear Height:	3.5 cm	3.5 cm	2.5 cm	4 cm
Liquid Height:	6 cm	5.5 cm	6 cm	6 cm
Other:	Purple, light purple, pink	light green, blue, yellow	pink, orange	orange, pink, blue

The independent variable(s) is(are) the changing variable(s) and the dependent variables are the final measurements/observations.

RESULTS

Graph

Set up your graph. (Check off the steps as you complete them.)

- Label the y-axis (vertical) with what you measured, including units (Ex: smear height (cm)).
- Determine an appropriate scale which will allow you to graph all of your data points and write the numbers on the given lines.
- Label the x-axis (horizontal) with your changing variable(s) #1, #2, and #3 (Ex: liquid type). Changing variable #2 and #3 will only be filled in if you have 2 or 3 changing variables.
- On your results table, label your measurements from 1 to 4, with 1 being the trial with the smallest measurement and 4 being the trial with the largest measurement.

Plot your data in increasing order.

- Write the changing variable value(s) (Ex: soap) for the trial that you labeled 1 under the first column.
- Graph your data for that trial and write the measurement above the bar.
- Repeat the process for the other trials.

Pen Color:	Orange	Light Green	Purple	Black
Changing Variable #1	:	:	:	:
Changing Variable #2	:	:	:	:
Changing Variable #3	:	:	:	:

CONCLUSION

We can conclude that the pen color does not greatly affect the smear height, but does affect the color of the smear

because the smear height for the light green and purple pens were 3.5 cm, but we observed the smears for the light green pen contained light green, blue, and yellow while the smear for the purple pen contained purple, light purple and pink

Can you test the first part (claim) of the conclusion?

YES NO (If you checked this box go back and revise your claim so that it can be.)

The second part of the conclusion is data because it contains a measurement

I acted like a scientist when I observed the colors of the smears and measured the smear heights.

Preparation:

SciTrek Lead:

1. Make sure volunteers are passing out notebooks.
2. Make sure volunteers are setting up for the experiment.
3. Set up the document camera for the conclusion example (notebook, page 18).

SciTrek Volunteers:

1. Pass out notebooks/nametags.
2. Pour all of the liquids your subgroups will need into the small, labeled cups.
3. Have test tube stands, liquids, bags with supplies (labeled with subgroup numbers), and rulers ready to give subgroups when they finish their results table.

Note: Pass out notebooks to students. If needed, students will move to their subgroups after the Introduction.

Introduction:

(20 minutes – Full Class – SciTrek Lead)

If students are not in their subgroups, tell them, “You will move to your subgroups after the Introduction.”

Ask the class, “What is the class question we have been investigating?” Students should reply, “What variables affect smears?” Tell students, “Today, you are going to perform your second experiment. Once the experiment is complete, you will analyze your data, and determine what conclusions can be drawn from your results. Your conclusions will help answer the class question.” Ask students, “What is the definition of a conclusion?” Students should reply, “A claim supported by data.” Ask students, “Could we all make conclusions from our data in the first experiment?” Students should reply, “No.” Ask students, “Why not?” Possible student response: because some of us had more than one changing variable. Ask students, “How many changing variables can experiments have in order to make claims/conclusions?” Students should reply, “One changing variable.” Ask them, “Why can we only have one changing variable in order to draw a conclusion?” Possible student response: if there is more than one changing variable, we would not be able to tell which one of the multiple changing variables affects the smear.

Tell students, “To help learn how to analyze data, we will look at other scientists’ data to see if we can draw a conclusion from their results.” Have students turn to page 18 of their notebook, and place the class notebook under the document camera turned to that page. Tell students, “Look over the data in this results table.” Ask students, “What was the changing variable in the experiment?” Students should reply, “Paper height.” Have students circle *Paper height*. Next, have students identify and underline, the controls for the experiment. Students should underline *container, time, liquid type, liquid amount, paper type, pen color, pen type, and initial dot height*. Lastly, have students identify the data the scientists collected and box that information. Students should box *smear height, liquid height, and other*. Ask students, “What was the question these scientists were exploring?” Students should reply, “If we change the paper height, what will happen to the liquid height?” Fill in the changing variable in the blank in the question above the results table in the class notebook while students do the same in their notebooks. Ask students, “Can a claim/conclusion be made from this data?” Students should realize there is only one changing variable, so a claim/conclusion can be made from these results.

Next, draw a picture on the board of what happened in each trial. To have students help you with the drawings, ask students the following set of questions:

What was the paper height was for trial A?

5 cm. (Draw the paper on the board and label it A.)

Where was the dot on the paper?

2 cm (Draw a line and dot proportionate to the paper sizes at what would be 2 cm.)
 What was the liquid height for trial A? and was this at the top of the paper?
 5 cm and this is the top of the paper. (Draw a wavy line to represent the water at the appropriate height.)
 What was the smear height for trial A?
 3 cm

Why is the smear height shorter than the water height?
 Students should realize the smear height starts at the line (2 cm from the bottom of the strip) and the water level starts at the bottom of the strip. (Draw on the smear starting at the line with the dot.)

Repeat the process for the other trials (see example drawing below). Ask students, "Do you see any trends in the liquid heights?" Possible student response: the liquid heights for the 10 cm and 5 cm papers reached the top of the paper, but the liquid heights for the 15 cm and 20 cm papers were both 11 cm. Next, have students make several predictions about what would happen to the liquid and smear height if the paper height was several different sizes. For example, ask students, "Would the liquid reach the top of the paper, if the paper height was 8 cm?" Students should reply, "Yes." Ask students "Would the liquid reach the top of the paper, if the paper height was 13 cm?" Students should reply, "No." After making several predictions, ask students, "What is the tallest paper height that would still allow the liquid to reach the top of the paper?" Students should reply, "11 cm."

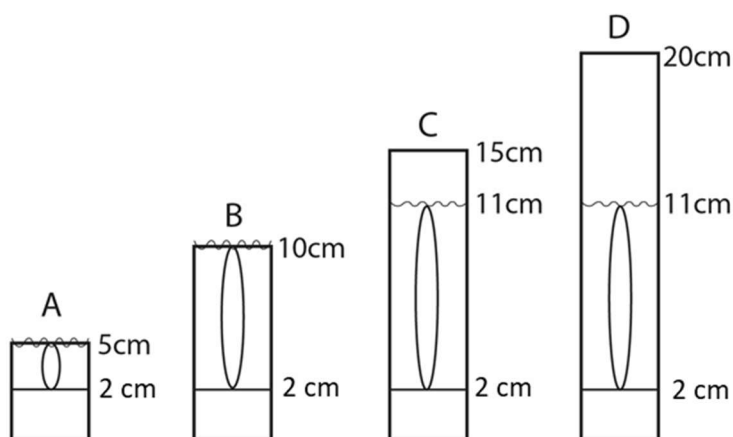

After students have a clear idea of what happened in the experiment, ask them, "Can anyone look at the data and tell me how the paper height affected the liquid height?" Possible student response: as paper height increases, liquid height increases, until liquid height reaches a maximum of 11 cm tall.

Explain, when drawing a conclusion from data, the first step is making a claim to explain the results. Then ask, "Can anyone look at the drawings and make a claim that tries to explain these results?"

Example claims that state how the liquid height is affected by the paper height:

1. the liquid will reach the top of the paper if the paper is 11 cm or shorter
2. if the paper height is larger than 11 cm, the paper height will not affect liquid height

Example claim that states what happened:

1. the paper height affects the liquid height

If possible, try to lead the students to a claim that explains how the liquid height was affected instead of a claim that just states what happened to the liquid height. The underlined dotted claim above is the claim that most classes generate. Tell students, "Claims that allow you to make predictions are more valuable in science, because we can go out and further test our claims to see if they are correct. Therefore, when you try to generate a claim about your data, you should try to have a claim that would allow you to make a prediction." Write the claim in the class notebook, and have students copy it into theirs.

Ask students, “What data was collected to support this claim?” Lead students to select the two most convincing data points to support their claim, in this case it will be one of the strips in which the liquid did not reach the top of the paper and one of the strips in which the liquid did reach the top of the paper. Below are examples of data that supports claims that stated how the liquid was affected. The underlined dotted data below corresponds to the underlined dotted claim above.

1. when the paper height was 5 cm, the liquid height was 5 cm (same as the paper height) and when the paper height was 20 cm, the liquid height was only 11 cm (not the top of the paper)
2. when the paper height was 15 cm and 20 cm, the liquid height was 11 cm

Ask students, “How do you know that the statement generated was data?” Possible student response: the statement contains measurements, showing that scientists had to go and physically carry out an experiment to discover the results. Write the data after the claim in the class notebook and have students copy it into their notebooks. Make sure students understand the conclusions they will make will be the outcome of their experiments and should answer their experimental questions. In addition, these smaller experimental questions can be combined to help answer a larger question, such as the class question.

Note: If the experimental question was asked about the smear height or the smear color, below are appropriate conclusions for those questions.

1. If the paper height is greater than 11 cm, the smear height will be 9 cm, because when the paper height was 20 cm and 15 cm the smear height was 9 cm.
2. If the liquid level is the same as the paper height, then the smear height will be 2 cm shorter than the paper height, because when the paper height was 10 cm and 5 cm and the liquid height was the same as the paper height, the smear heights were 8 cm and 3 cm respectively, both were 2 cm shorter than the paper height.
3. The height of the paper affects the smear, because when the paper height was 20 cm, the smear height was 9 cm and when the paper height was 10 cm, the smear height was 8 cm.
4. The colors that the black dot separates into are the same, regardless of the paper height, because the colors of the smears were observed to be blue, orange, and red for all four trials.
5. The height of the paper does not affect the colors of the smear, because the colors of the smears were observed to be blue, orange, and red for all four trials.

Remind students, “To keep track of which test tube corresponds to which trial, you can use a blue, wet erase marker and write directly onto the top portion of the test tube.”

Tell students, “After you have fished your results table, you can start your experiment and graph your data. This will help you make a conclusion about how your changing variable affects smears.”

SCIENTIFIC PRACTICES
Conclusions

Question: If we change the Paper height what will happen to the liquid height?

Variables	Trial A	Trial B	Trial C	Trial D
Container:	Test Tube			
Time:	5 min			
Liquid Type:	Water			
Liquid Amount:	2 ml			
Paper Type:	Original			
Pen Color:	Black			
Pen Type:	Mr. Sketch			
Initial Dot Height:	2 cm			
Paper Height:	5 cm	10 cm	15 cm	20 cm

Data	Trial A	Trial B	Trial C	Trial D
Smear Height:	3 cm	8 cm	9 cm	9 cm
Liquid Height:	5 cm	10 cm	11 cm	11 cm
Other:	blue orange red	blue orange red	blue orange red	blue orange red

Write a conclusion from the results above:

We can conclude that the liquid will reach the top of the paper if the paper is 11 cm or shorter because when the paper height was 5 cm, the liquid height was 5 cm (same as the paper height) and when the paper height was 20 cm, the liquid height was only 11 cm (not the top of the paper).

18

RESULTS
Table

Fill out the chart for each of your trials. For the variables that remain constant, write the value in trial E. Then, draw an arrow through each box indicating that this variable is a control.

Variables	Trial E	Trial F	Trial G	Trial H
Container:	Test Tube			
Time:	4.5 min			
Liquid Type:	Water			
Liquid Amount:	5 mL			
Paper Type:	Original			
Pen Color:	Purple	light green	Orange	Black
Pen Type:	Mr. Sketch			
Initial Dot Height:	2 cm			
Cap Placement:	On			

Predictions	Trial E	Trial F	Trial G	Trial H
Put a "T" in the trial that will give the tallest smear and an "S" in the trial that will give the shortest smear.	T		S	

Data	Trial E	Trial F	Trial G	Trial H
Smear Height:				
Liquid Height:				
Other:				

The independent variable(s) is(are) the changing variable(s) and the dependent variables are the final measurements/observations.

19

Results Table:

(5 minutes – Subgroups – SciTrek Volunteers)

If your subgroup has not finished their procedure, make sure they do this before moving on to their results table.

Have students underline the variables that are controls, circle the variable that is their changing variable, and box information about data collection. When writing the values make sure for controls, they only write the value of the control in the *Trial E* box, then, draw an arrow through the remaining trials' boxes. For the changing variable, they should write the values in each trial's corresponding box.

When students have finished, have them make predictions about the smears. Have them write an "S" in the box of the trial they think will produce the smallest smear and a "T" in the box of the trial they think will produce the tallest smear. They will leave two of the boxes empty. If they think all trials will produce the same smear height, have them write "same" over all of the boxes. It is okay if the students in a subgroup have different predictions. An example filled-out results table is shown in the Graph section.

Experiment:

(20 minutes – Subgroups – SciTrek Volunteers)

Once subgroups have finished their results tables, give them their requested materials. If students are missing any of their experimental materials, the lead box has extra materials. Students should label each of their test tubes with the trial letters (E, F, G, and H) using a blue, wet erase pen. In addition, make sure students draw their initial dot height line and label their strips (E, F, G, and H) using a pencil, not a pen, so they can tell them apart later. As soon as students are done with their liquids, remove the liquids, graduated cylinders, and droppers, and put them in the bucket (please do not put trash in the bucket). It is important to do this as soon as possible so students do not play with, or spill, their liquids. When the experiment is finished, place all test tubes and caps in the bucket and put the test tube stand, timer, and

pens, in your group box. Once students have finished their experiments, they can record their findings. Make sure subgroups trace the liquid line (with pencil) onto their strips so they can easily see/measure it later, if needed. Once students have finished their measurements, have them place their strips in a safe place so they can attach them to their notebook at the end of the day. If your group has things under control, help other subgroups. As soon as subgroups finish their experiments, they can graph their results. An example filled-out results table is shown below (left).

Graph:

(5 minutes – Subgroups – SciTrek Volunteers)

Help subgroups fill out their graphs by having them complete the checklist on the top of page 20. Be sure students label the y-axis with “Smear Height (cm)” (or “Liquid Height (cm),” if needed) and the x-axis with their changing variable. If students pick systems in which the dot did not smear, they can go back to page 15 and revise their question from “...what will happen to the height of the smear?” to “...what will happen to the height of the liquid?” Students will need to decide what scale to use on the y-axis. Students can use halves, ones, or twos. Step 4 of the graphing checklist has students label their measurements in increasing order (1-4) on their results table to ensure that they are graphed in increasing order, as seen in the example below. This makes it easier for the students to see trends in their data. In the example below, the trials were graphed in the following order: G, F, E, H. Once students have graphed their values, make sure they write the numerical value of the smear or liquid height on top of each column, so it is easy to quickly read the graph. An example filled-out graph is shown below (right).

RESULTS Table				
Fill out the chart for each of your trials. For the variables that remain constant, write the value in trial E. Then, draw an arrow through each box indicating that this variable is a control.				
Variables	Trial E	Trial F	Trial G	Trial H
Container:	Test Tube			
Time:	4.5 min			
Liquid Type:	Water			
Liquid Amount:	5 mL			
Paper Type:	Original			
Pen Color:	Purple	light green	Orange	Black
Pen Type:	Mr. Sketch			
Initial Dot Height:	2 cm			
Cap Placement:	On			
Predictions	Trial E	Trial F	Trial G	Trial H
	T		S	
Data	Trial E	Trial F	Trial G	Trial H
	3	2	1	4
Smear Height:	3.5 cm	3.5 cm	2.5 cm	4 cm
Liquid Height:	6 cm	5.5 cm	6 cm	6 cm
Other:	Purple, light purple, pink	light green, blue, yellow	Pink, orange	orange, pink, blue

The independent variable(s) is(are) the changing variable(s) and the dependent variables are the final measurements/observations.

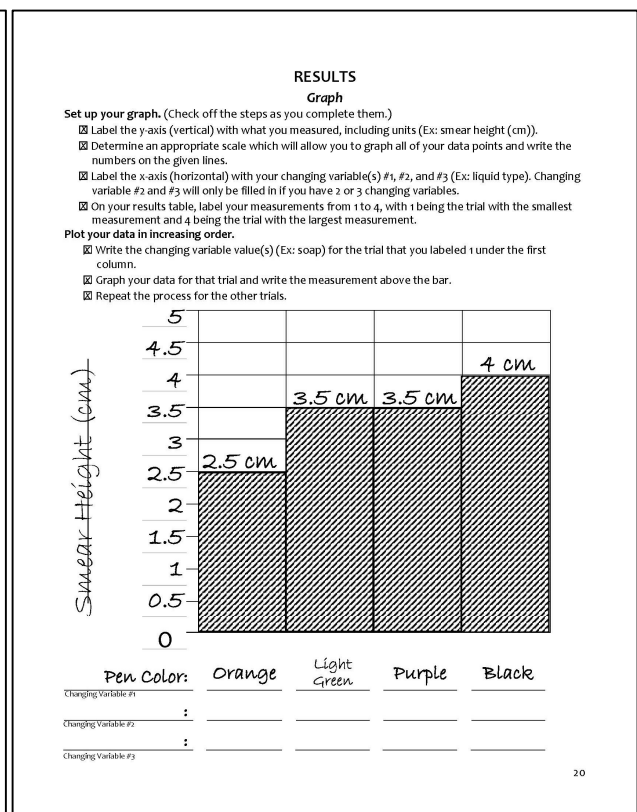

Conclusion:

(8 minutes – Subgroups – SciTrek Volunteers)

Have subgroups use their graphs to look for patterns in their data. Challenge subgroups to think about how their changing variable did, or did not, affect the smear or liquid height.

When writing their conclusion (notebook, page 21), make sure subgroups begin the statement with a claim (statement that can be tested) about the trend or pattern in their data. If the values of their changing variable have an order (Ex: 1 min → 3 min → 5 min), then that variable does have an effect on the smear height. If, on the other hand, there was no order for their changing variable values (Ex: 0.5 cm → 1 cm → 1.5 cm), and/or the difference between the smear heights for each trial is small, then that variable does not have an effect on the smear height. If possible, try to have subgroups generate a claim that allows them to make predictions about something they have not tested. Challenge subgroups to think about how (claims 1 and 2 below) their changing variable does or does not affect their measurements, instead of just what happened (claims 3 and 4 below). For this experiment, we will not focus on why the dot is spreading up the paper.

Example claims that state how the changing variable did or did not affect the smear.

Claim 1: the more absorbent the paper, the larger the smear

Claim 2: the more time, the taller the smear

Example claims that state what happened to the smear.

Claim 3: the paper type affected the height of the smear

Claim 4: the color of the pen did not affect the height of the smear

Once they have discussed their ideas, have the subgroups fill out the section labeled, “Generate a claim about how your changing variable affected your results” (notebook, page 21).

If subgroups made a claim about the liquid height, instead of the smear height, have them go back and revise their question (notebook, page 15).

If there is time, subgroups can determine the data to support their claim. For an example of how to do this, see the Conclusion section on Day 6. Example student work for the conclusion section can be seen below.

CONCLUSION

<p>Generate a claim about how your changing variable affected your results. (Ex: the shorter the paper the shorter the smear height.)</p>	<p>We can conclude <u>that the pen color does not greatly affect the smear height, but does affect the color of the smear</u></p>
<p>What data do you have to support your claim? (Remember to include your measurements and/or observations, <u>not trail letters</u>.)</p>	<p>because <u>the smear height for the light green and purple pens were 3.5 cm, but we observed the smears for the light green pen contained light green, blue, and yellow while the smear for the purple pen contained purple, light purple and pink</u></p>

Can you test the first part (claim) of the conclusion?
 YES NO (If you checked this box go back and revise your claim so that it can be.)

The second part of the conclusion is data because it contains a measurement

I acted like a scientist when I observed the colors of the smears and measured the smear heights.

21

Wrap-Up:

(2 minutes – Subgroups – SciTrek Lead)

Tell students, “Next session, you will have time to finish your conclusions, and then make a poster to share your results with the class.” Show students how to attach their strips to the front of their notebooks, so they will have them next time when they make their posters.

Clean-Up:

1. Collect notebooks with attached nametags.
2. Make sure the strips are attached via a nametag to one student’s notebook.
3. Put all liquids and dishes into the bucket.
4. Place all other materials into your group box and bring them back to UCSB.

Day 6: Conclusion/Poster Making**Schedule:**

Introduction (SciTrek Lead) – 2 minutes

Conclusion (SciTrek Volunteers) – 18 minutes

Poster Making (SciTrek Volunteers) – 35 minutes

Wrap-Up (SciTrek Lead) – 5 minutes

Materials:

(3) Volunteer Boxes:

- | | | |
|---|---|---|
| <input type="checkbox"/> Nametags | <input type="checkbox"/> (2) Pencils | <input type="checkbox"/> (3) Poster parts packs |
| <input type="checkbox"/> Notebooks | <input type="checkbox"/> Paper notepad | (scientists' names, question, |
| <input type="checkbox"/> Volunteer instructions | <input type="checkbox"/> (Bag) Paperclips | experimental set-up, procedure, |
| <input type="checkbox"/> Volunteer lab coat | <input type="checkbox"/> Highlighter | results table, results graph, |
| <input type="checkbox"/> Poster diagram | <input type="checkbox"/> Scissors | conclusion, (4) <i>I acted like a</i> |
| <input type="checkbox"/> (3) Stickers on how to present graph | <input type="checkbox"/> (2) Glues | <i>scientist when</i> , (4) picture spaces) |

Other Supplies:

-
- Poster paper tube

Lead Box:

- | | | |
|--|---|---|
| <input type="checkbox"/> (3) Extra notebooks | <input type="checkbox"/> (3) Stickers on how to present graph | <input type="checkbox"/> (2) Highlighters |
| <input type="checkbox"/> Lead instructions | <input type="checkbox"/> (2) Pencils | <input type="checkbox"/> (2) Scissors |
| <input type="checkbox"/> Chromatography picture packet | <input type="checkbox"/> (2) Wet erase markers | <input type="checkbox"/> (2) Glues |
| <input type="checkbox"/> Lead lab coat | <input type="checkbox"/> (2) Black pens | <input type="checkbox"/> Scotch tape |
| <input type="checkbox"/> Poster diagram | <input type="checkbox"/> Paper notepad | <input type="checkbox"/> (3 each color) Poster part packs |
| <input type="checkbox"/> Time card | <input type="checkbox"/> (Bag) Paperclips | |

Preparation:

SciTrek Lead:

1. Make sure volunteers are setting out notebooks.
2. Find a place to leave student posters.

SciTrek Volunteers:

1. Set out notebooks/nametags.

Note: Set notebooks where students will sit during the module, even if another student is currently at that desk. If needed, students will move to these spots after the Introduction.

Notebook Page:

CONCLUSION

<p>Generate a claim about how your changing variable affected your results. (Ex: the shorter the paper the shorter the smear height.)</p>	<p>We can conclude <u>that the pen color does not greatly affect the smear height, but does affect the color of the smear</u></p>
<p>What data do you have to support your claim? (Remember to include your measurements and/or observations, <u>not trail letters</u>.)</p>	<p>because <u>the smear height for the light green and purple pens were 3.5 cm, but we observed the smears for the light green pen contained light green, blue, and yellow while the smear for the purple pen contained purple, light purple and pink</u></p>

Can you test the first part (claim) of the conclusion?
 YES NO (If you checked this box go back and revise your claim so that it can be.)

The second part of the conclusion is data because it contains a measurement

I acted like a scientist when I observed the colors of the smears and measured the smear heights.

21

Introduction:

(2 minutes – Full Class – SciTrek Lead)

If students are not in their subgroups tell them, “A notebook will be put on your desk, which is not your notebook and you should not move it. You will move to your notebook after the Introduction.”

Ask the class, “What is the class question we have been investigating?” Students should reply, “What variables affect smears?” Tell students, “Today, you are going to finish your conclusions and make posters to present your findings to the class.” Ask students, “How do scientists define a conclusion?” Students should reply, “A claim supported by data.” Ask students, “What is a claim?” Students should reply, “A statement that can be tested.” Ask students, “What can be used for data?” Students should reply, “Measurements or observations.”

Tell students, “After you finish your conclusion, you will fill in the sentence frame *I acted like a scientist when*, stating how you acted like a scientist during your SciTrek experience. Try to come up with a unique answer that is something besides ‘I did an experiment.’”

Tell students, “When scientists complete their experiments, they make posters to present their findings to other scientists. Each subgroup will create a poster to present to the class during the next session. You will get to pick which one of your two experiments to present, but it should be an experiment in which you were able to draw a conclusion. This presentation will be your chance to tell the class what your subgroup has discovered about the class question. You should write as neatly as possible on the poster parts, so the other class members can read your posters. You will now start working with your subgroup to analyze your experimental results, and make a poster.”

Conclusion:

(18 minutes – Subgroups – SciTrek Volunteers)

If subgroups have not made a claim about their data, have them analyze the data in their graph in order to make one. For an example of how this is done, see the Conclusion section in Day 5.

After generating a claim about their experiment, subgroups will put their supporting data after the *because* in their conclusion sentence. Their supporting data should include at least two pieces of data, typically the minimum and maximum heights. Make sure subgroups are using their changing variable values (not trial letters) and specific measurements, to support their claims.

Example data to support the four claims that were previously listed.

Data 1: the smear on the paper towel (most absorbent) was 3 cm and the smear on the copy paper (least absorbent) was 0.5 cm

Data 2: the strip that sat in the liquid for 1 minute had a 1 cm smear and the strip that sat in the liquid for 5 minutes had a 4 cm smear

Data 3: the smear on the paper towel was 3 cm and the smear on the copy paper was 0.5 cm

Data 4: all of the smears by the Mr. Sketch pens, regardless of color, were about 3 cm long

Conclusions are still valid, and important, if they show the changing variable tested does not have an effect on the smear. Even if their conclusion is contrary to what you think, have subgroups make a claim based solely on their data.

Once subgroups have written their conclusions, have them complete the two questions that follow. First, have them verify that the first part of their statement is testable, making it a claim. If it is not a claim, have them go back and revise the first part of the statement. Second, have students justify how they know the second part of the statement is data. Statements that are data contain measurements or observations. If the statement is an observation, make sure the word “recorded” or “observed” is in the statement to indicate that the experiment was carried out. If the data statement does not have a measurement or an observation, have students modify their statement.

An example filled-out conclusion is shown below.

CONCLUSION

Generate a claim about how your changing variable affected your results. (Ex: the shorter the paper the shorter the smear height.)

What data do you have to support your claim? (Remember to include your measurements and/or observations, not trail letters.)

We can conclude that the pen color does not greatly affect the smear height, but does affect the color of the smear

because the smear height for the light green and purple pens were 3.5 cm, but we observed the smears for the light green pen contained light green, blue, and yellow while the smear for the purple pen contained purple, light purple and pink

Can you test the first part (claim) of the conclusion?
 YES NO (If you checked this box go back and revise your claim so that it can be.)

The second part of the conclusion is data because it contains a measurement

I acted like a scientist when I observed the colors of the smears and measured the smear heights.

21

Once students have filled out their conclusion, have them fill in the sentence frame, *I acted like a scientist when* (notebook, page 21). Each student’s response should be unique and specific. They should **not** write, “when I did an experiment,” because this is general and applies to all of the students in the class. If students are having trouble with this sentence frame, ask them, “What did you do during SciTrek?”

Poster Making:

(35 minutes – Subgroups – SciTrek Volunteers)

Each subgroup (three/four students) will make one poster for one of their experiments from which they were able to draw a conclusion. If a subgroup was able to make a conclusion from both experiments, they can choose whichever experiment they think will better help answer the class question. Every student in the subgroup will have both a writing and a speaking part in their presentation.

Pass out the writing portions (general poster parts and *I acted like a scientist when*) and have students write their names on them and complete them. In addition, have each student write their name on the scientists’ names poster part. Use the following guidelines when assigning poster parts:

Number of Students in Subgroup	Poster Division
3	Each student gets an <i>I acted like a scientist when</i> and picture space. 1. Question and Experimental Set-Up Student who finishes 1 st completes the results table (<u>not</u> presented) 2. Procedure 3. Results Graph* and Conclusion
4	1. Question and Experimental Set-Up 2. Procedure Student who finishes 1 st completes the results table (<u>not</u> presented) 3. Results Graph* 4. Conclusion

*Give the results graph to the student who is most confident in presenting.

Once students have finished their written section(s), have them draw a picture of their experiment or how they acted like a scientist.

In the students' notebooks, highlight and number the section(s) that they will present. The parts should be numbered as follows: 1) scientists' names, 2) question, 3) experimental set-up, 4) procedure, 5) results graph, and 6) conclusion (see example below). Students will **not** present the results table or *I acted like a scientist when* parts from their poster. If a student is presenting multiple sections, use the paperclips in your group box to clip together the sections they are reading, so when presenting, it will be easy for them to flip back and forth between the pages.

Changing Variable(s) (Independent Variable(s))

For your second experiment, decide which variable(s) (max three) you would like to test.

Changing Variable 1: Pen Color

Changing Variable 2 (optional): _____

Changing Variable 3 (optional): _____

#1 The scientists in our group are _____

#2 QUESTION

Question our subgroup will investigate:

• If we change the pen color what will happen to the height and color of the smear

SciTrek Member Approval: DF

#3 EXPERIMENTAL SET-UP

Write your changing variable(s) (Ex: pen color) and the values (Ex: blue) you will use for your trials under each strip of paper.

E

F

G

H

Changing Variable(s):

1) Pen Color: Purple Light Green Orange Black

2) _____

3) _____

Controls (variables you will hold constant):

Write your controls and the values you will use in all your trials (control value, Ex: container/test tube).

Container / Test Tube Pen Type / Mr. Sketch
Liquid Type / Water Time / 4.5 min
Liquid Amount / 5 ml Paper Type / Original
Cap Placement / on Initial Dot / 2 cm
Height

SciTrek Member Approval: DF

#4 PROCEDURE

Procedure Note: Make sure to include all values of your changing variable(s) in the procedure (x: For a subgroup that decided to change pen color, one step would be: Put colored dot with Mr. Sketch pens (E) red, F) blue, G) green, and H) yellow on original paper at 2 cm.

- Fill 4 test tubes with 5 ml of water.
- Draw dots at 2 cm on original papers with a E) purple, F) light green, G) orange, and H) black Mr. Sketch.
- Put papers in test tubes and put caps on.
- Wait for 4.5 minutes.
- Remove papers.
- Measure smear heights and observe smear colors.

SciTrek Member Approval: DF

Highlighted and Numbered Notebook Pages

#5 RESULTS Graph

Set up your graph. (Check off the steps as you complete them.)

- Label the y-axis (vertical) with what you measured, including units (Ex: Smear Height (cm)).
- Determine an appropriate scale which will allow you to graph all of your data points and write the numbers on the given lines.
- Label the x-axis (horizontal) with your changing variable(s) #1, #2, and #3 (Ex: Liquid Type). Changing variables #2 and #3 will only be filled in if you have 2 or 3 changing variables.
- On your results table, label your measurements from 1 to 4, with 1 being the trial with the smallest measurement, and 4 being the trial with the largest measurement.
- Plot your data in increasing order.
- Write the changing variable value(s) (Ex: Soap) for the trial that you labeled 1 under the first column.
- Graph your data for that trial and write the measurement above the bar.
- Repeat the process for the other trials.

Pen Color: Orange Light Green Purple Black

The Smear height for _____ was _____

#6 CONCLUSION

Generate a claim about how your changing variable affected your results. (Ex: the shorter the paper the shorter the smear height.)

What data do you have to support your claim? (Remember to include your measurements and/or observations, not trial letters.)

We can conclude that the pen color does not greatly affect the smear height, but does affect the color of the smear

because the smear height for the light green and purple pens were 3.5 cm, but we observed the smears for the light green pen contained light green, blue, and yellow while the smear for the purple pen contained purple, light purple and pink

Can you test the first part (claim) of the conclusion?
 YES NO (If you checked this box go back and revise your claim so that it can be.)

The second part of the conclusion is data because it contains a measurement

I acted like a scientist when I observed the colors of the smears and measured the smear heights.

Place the following sentence frame sticker on the notebook page of the student who is presenting the results graph (notebook, page 20).

The _____ (fill out this blank for the student) for _____ was _____.
 what was measured changing variable value measurement

Then, practice reading the four sentences with that student. For the graph above, the first sentence would read: The **smear height** for **rubbing alcohol** was **4.5 cm**. Make sure you fill in the first blank (*what was measured*) in the sentence frame (Ex: smear height) for the student, but leave the *changing variable value* and *measurement* blanks empty. The student will fill these in verbally for each data piece.

As soon as students have completed some of their pieces, start gluing them onto the large poster paper, in landscape orientation, exactly as they are arranged in the example below. Do not allow students to glue the poster parts on the posters. Do not wait until students have completed all the pieces to start gluing them onto the posters.

Once the poster is complete, have students start practicing for the presentation. Make sure students read from their notebooks, instead of from the poster.

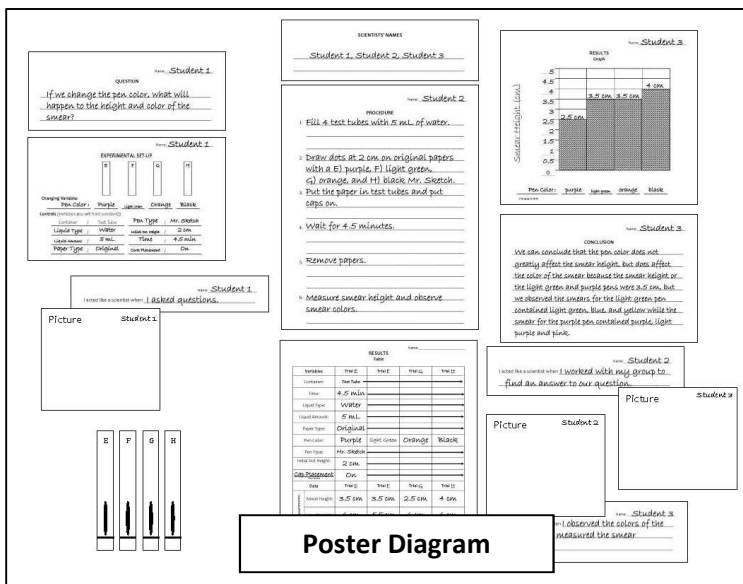

Ask each of your subgroups a few questions about their posters. Have them use their findings to predict what would happen to the smear height or liquid height for other changing variable values they did not perform tests on. For instance, if the subgroup’s conclusion was, “The thicker the liquid, the smaller the smear, because soap gave a 1 cm smear height and water gave a 6 cm smear height,” ask the subgroup to predict the smear height if the liquid was honey. They should be able to predict that it would be less than 1 cm because honey is thicker than soap.

If there is additional time, tell each subgroup, “Other students will ask you questions during your poster presentations. You should think about what questions you might be asked, and think of the answers to those questions, so you will be prepared during your presentation.”

Wrap-Up:
(5 minutes – Full Class – SciTrek Lead)

- Ask students the following questions:
- How did you act like a scientist during this project?
 - What did you do, that scientists do?

After discussing how they acted like scientists, and talking about how everyone does things scientists do in their everyday lives, tell students, “Next session, you will present your findings to the class, and I am looking forward to hearing about all of your experiments.”

Clean-Up:

1. Collect notebooks with attached nametags.
2. Leave posters in the classroom.
3. Place all other materials into your group box and bring them back to UCSB.

Day 7: Poster Presentations
Schedule:

Introduction (SciTrek Lead) – 2 minutes
 Practice Posters (SciTrek Volunteers) – 5 minutes
 Poster Presentations (SciTrek Volunteers/SciTrek Lead) – 51 minutes
 Wrap-Up (SciTrek Lead) – 2 minutes

Materials:

(3) Volunteer Boxes:

- | | | |
|---|---|---|
| <input type="checkbox"/> Nametags | <input type="checkbox"/> Volunteer lab coat | <input type="checkbox"/> (Bag) Paperclips |
| <input type="checkbox"/> Notebooks | <input type="checkbox"/> (2) Pencils | <input type="checkbox"/> Highlighter |
| <input type="checkbox"/> Volunteer instructions | | |

Lead Box:

- | | | |
|--|--|--|
| <input type="checkbox"/> (3) Extra notebooks | <input type="checkbox"/> Time card | <input type="checkbox"/> (2) Wet erase markers |
| <input type="checkbox"/> Lead instructions | <input type="checkbox"/> Teacher Final Survey QR code | <input type="checkbox"/> (2) Black pens |
| <input type="checkbox"/> Chromatography picture packet | <input type="checkbox"/> (3) Stickers on how to present <i>Graph</i> | <input type="checkbox"/> (Bag) Paperclips |
| <input type="checkbox"/> Lead lab coat | <input type="checkbox"/> (2) Pencils | <input type="checkbox"/> (2) Highlighters |
| | | <input type="checkbox"/> Scotch tape |

*Student posters should already be in the classroom.

Preparation:

SciTrek Lead:

1. Make sure volunteers are passing out notebooks.
2. Set up the document camera for the *Notes on Presentations* (picture packet, pages 3 and 4).
3. Organize posters so experiments featuring the same changing variable will be presented back-to-back and posters are presented from simplest to understand, to most difficult to understand (suggested order: time, paper type, liquid type, dot height, liquid amount, pen type, and pen color).

SciTrek Volunteers:

1. Pass out notebooks/nametags.

Note: Today, students will sit in their regular classroom seats during poster presentations.

Picture Packet Pages: (Notebook pages 22 and 23 are almost identical to picture packet pages 3 and 4, but have one less subgroup space.)

NOTES ON PRESENTATIONS
What variables affect smears?

Subgroup 1

Changing Variable: Time (min)	1	2	3	5
Smear Height (cm):	0.5	5	7.5	10

Summary: A longer time results in a taller smear.

Subgroup 2

Changing Variable: Paper Type	graph	news	paper towel	coffee filter
Smear Height (cm): Liquid Height	2	2.5	8	9

Summary: Sharpie does not smear in water.

Subgroup 3

Changing Variable: Paper Type	Construction	news	original	paper towel
Smear Height (cm):	0	0.5	4	8

Summary: More absorbent papers make taller smears.

Subgroup 4

Changing Variable: Liquid Type	soap	RA	vinegar	water
Smear Height (cm):	0.5	3	4	6

Summary: Thicker liquids result in shorter smears.

Picture Packet, Page 3

3

Subgroup 5

Changing Variable: Liquid Type	soap	Vinegar	RA	Water
Smear Height (cm):	1	3	4	6

Summary: Agrees with previous subgroup.

Subgroup 6

Changing Variable: Initial Dot Height (cm)	1	2	4	3
Smear Height (cm):	1, down	2, down	5, up	6, up

Summary: If the liquid is above the dot, the smear goes down.

Subgroup 7

Changing Variable: Liquid Amount (mL)	10	20	1	5
Smear Height (cm):	2, down	2, down	3, up	7, up

Summary: When the liquid is just below the dot, it smears up the highest.

Subgroup 8

Changing Variable: Liquid Amount (mL)	Sharpie	Crayola	Mr. Sketch	Expo
Smear Height (cm):	0	7.5	7.5	8

Summary: Washable markers make smears and permanent markers do not.

Subgroup 9

Changing Variable: Pen Color	Orange	Light Green	Purple	Black
Smear Height (cm):	2.5	3.5	3.5	4

Summary: Pen color affect smear color more than smear height.

Picture Packet, Page 4

4

Introduction:

(2 minutes – Full Class – SciTrek Lead)

Tell students, “Today you will present your posters to the class. This is a common practice in science. Scientists go to conferences where they present posters about the experiments they conducted. At these presentations, other scientists give them feedback on their experiments, which allows them to return to the lab with new ideas for future experiments. You will have 5 minutes to practice presenting your poster with your subgroup. When you present, you should read from your notebooks, not your poster. After practicing, you will return to your normal classroom seats.”

Practice Posters:

(5 minutes – Subgroups – SciTrek Volunteers)

Have subgroups practice their poster presentation, making sure they are reading the poster parts in the correct order (scientists’ names, question, experimental set-up, procedure, results graph, and conclusion). Make sure each student’s part is highlighted in their notebook. If students are reading from multiple pages, use a paperclip to clip these pages together, to make it easier for them to flip back and forth. Remind students to read from their notebooks rather than from their posters. If a student is absent, give the absent student’s notebook to another student in the group so they can ready their part.

Do not let poster practice go over 5 minutes.

Poster Presentations:

(51 minutes – Full Class – SciTrek Volunteers/SciTrek Lead)

Have students return to their original class seats. Ask the class, “What is the question we have been investigating?” Students should reply, “What variables affect smears?” Tell students, “During the presentations, you are going to take notes.” Have them turn to page 22 in their notebooks while you turn to page 3 of the picture packet. Tell them, “You will need to record each subgroup’s changing variable after the subgroup says their question. In addition, when the subgroup presents their graph, you will need to record the values of the changing variable, as well as the corresponding measurements collected by the subgroup.”

Tell students, “You will get the chance to ask scientific questions after each presentation. These questions are important, because you will have to summarize what you learned from the subgroup and record it in your notebook. Therefore, your questions should focus on helping you be able to summarize the subgroup’s findings.”

Notebooks only have room for notes on eight presentations. Therefore, students will not take notes on their own presentation.

Volunteers should make sure students are quiet and respectful when other subgroups are presenting. When one of your subgroups is presenting, go to the front of the room with them; prompt students if they do not know who talks next and remind them to read from their notebooks.

After each subgroup has given their presentation, take the poster and put the strips under the document camera, so that it may be seen during student question time. During this time, the lead and/or volunteers should ask at least one question. Examples of possible questions are: “How do you know...?” or “Is there anything else you can do to get more information about your question?” Each subgroup should answer approximately four questions (one question per student). When students are done asking questions, have them summarize what the subgroup found.

An example filled-out *Notes on Presentations*, are shown below.

NOTES ON PRESENTATIONS
What variables affect smears?

Subgroup 1

Changing Variable: Time (min)	1	2	3	5
Smear Height (cm):	0.5	5	7.5	10

Summary: A longer time results in a taller smear.

Subgroup 2

Changing Variable: Paper Type	graph	news	paper towel	coffee filter
Smear Height (cm):	2	2.5	8	9

Summary: Sharpie does not smear in water.

Subgroup 3

Changing Variable: Paper Type	Construction	news	original	paper towel
Smear Height (cm):	0	0.5	4	8

Summary: More absorbent papers make taller smears.

Subgroup 4

Changing Variable: Liquid Type	soap	RA	vinegar	water
Smear Height (cm):	0.5	3	4	6

Summary: Thicker liquids result in shorter smears.

Picture Packet, Page 3

3

Subgroup 5

Changing Variable: Liquid Type	soap	Vinegar	RA	Water
Smear Height (cm):	1	3	4	6

Summary: Agrees with previous subgroup.

Subgroup 6

Changing Variable: Initial Dot Height (cm)	1	2	4	3
Smear Height (cm):	1, down	2, down	5, up	6, up

Summary: If the liquid is above the dot, the smear goes down.

Subgroup 7

Changing Variable: Liquid Amount (mL)	10	20	1	5
Smear Height (cm):	2, down	2, down	3, up	7, up

Summary: When the liquid is just below the dot, it smears up the highest.

Subgroup 8

Changing Variable: Liquid Amount (mL)	Sharpie	Crayola	Mr. Sketch	Expo
Smear Height (cm):	0	7.5	7.5	8

Summary: Washable markers make smears and permanent markers do not.

Subgroup 9

Changing Variable: Pen Color	Orange	Light Green	Purple	Black
Smear Height (cm):	2.5	3.5	3.5	4

Summary: Pen color affect smear color more than smear height.

Picture Packet, Page 4

4

After all poster presentations have been given, ask the class, “What did we learn about smears?” Have them summarize the class findings. The highlights from many experiments are shown below. Do not expect students to know highlights from experiments that were not run.

- The longer the *time*, the taller the liquid/smear height.
- The more absorbent the *paper type*, the taller the liquid/smear height.
- The thinner the *liquid type*, the taller the liquid/smear height.
 - Different liquid types will change the order the colors appear in the smear, but not what colors appear.
- The lower the *dot height* (higher the *liquid amount*), the taller the smear (as long as the dot is not under the liquid level)
 - If the liquid level is above the dot, the smear will travel downwards.
- If the *pen type* is permanent, the only liquid that will make it smear is rubbing alcohol.
- Different *pen colors* are made up of different dye colors.
 - Colored markers separate into fewer colors than black markers.

When summarizing experiments, use student-collected data and not what they should have found from the list above. Ask students, “If you want to get the longest most colorful smear which values of the variables should you use?”

- Time: As long as possible
- Paper Type: The original paper or another absorbent paper
- Liquid Type: Water or another thin liquid
- Dot Height: A value that would put the dot close to the liquid level
- Liquid Amount: Enough to get the liquid close to the dot without going over the dot
- Pen Type: Any washable marker
- Pen Color: Black

If no one in the class did experiments on one of the variables above, they will not know how that variable affects smear height, so do not expect them to tell you which value to use. Tell students, “You have taught me a lot about the smears.”

Wrap-Up:

(2 minutes – Full Class – SciTrek Lead)

Tell students, “The mentors who have been working with you are undergraduate and graduate students who volunteer their time, so you can do experiments. This is the last day you will see your volunteers, so we should say thank you and goodbye to them. I will come back and work with you one more day.”

Have students remove the paper parts of their nametags (which they can keep) from the plastic holders and return the plastic holders to their volunteers.

Clean-Up:

1. Collect plastic nametag holders and allow students to keep the paper part of their nametags.
2. Collect notebooks.
3. Leave posters in the classroom.
4. Place all other materials into your group box and bring them back to UCSB.
5. If you will not be attending the tie to standards day, remove all items from your lab coat pockets, remove your nametag, unroll your lab coat sleeves, and put your lab coat into the dirty clothes bag at UCSB.

Day 8: Tie to Standards/Content Assessment

Note: We **highly recommend** teachers give the conclusion assessment prior to Day 8 of the module. The suggested times in the lesson plan below are assuming students completed the conclusion assessment prior to SciTrek’s arrival.

Schedule:
Times if teacher gave assessment prior to SciTrek:

Draw a Scientist (SciTrek Lead) – 5 minutes
 Tie to Standards (SciTrek Lead) – 45 minutes
 Content Assessment (SciTrek Lead) – 10 minutes

Times if SciTrek must give assessment:

Conclusion Assessment (SciTrek Lead) – 10 minutes
 Draw a Scientist (SciTrek Lead) – 5 minutes
 Tie to Standards (SciTrek Lead) – 35 minutes
 Content Assessment (SciTrek Lead) – 10 minutes

Materials:

Lead Box:

- (3) Extra notebooks
- Notebooks
- Lead instructions
- Chromatography picture packet
- Lead lab coat
- TTS Box, with the following:
 - Jar of sand and water
 - (2) Markers

- Conclusion assessment (if teacher did not take assessments, then (35))
- (35) Draw a scientist
- (35) Content assessments
- Time card
- (20) Pure substance bags labeled (sugar, salt, baking soda, and corn starch)

- (2) Pencils
- (2) Wet erase markers
- (2) Black pens
- Matter Poster
- Teacher final survey QR code
- (20) Pure substance bags labeled with letters (A=baking soda, B= sugar, C= salt, and D= corn starch)

Notebook Pages and Chart:

TIE TO STANDARDS

1. Circle the value of the variable that the police should use to process the evidence from the suspects that would give them the tallest smear.

Time: 3 min 5 min 10 min All would give similar height smears

Liquid Type: Water Soap Syrup All would give similar height smears

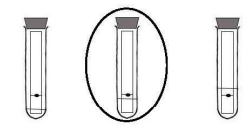
Amount of Liquid/Line Level:  All would give similar height smears

2. What conclusion can you make from the results the police collected?

We can conclude that the robber was number four claim because it was observed that the ink from the robber and number four were the same height and color. data

3. What did we learn about black ink? It is a mixture

24

Matter

Substances that Occupy Space and Have Mass

<p style="text-align: center;"><u>Mixture</u></p> <p>Materials made of two or more substances</p> <p>Ex: <u>Luck Charms</u> , <u>Salad</u></p> <p>Parts: <u>Marshmallows</u> <u>Lettuce</u></p> <p style="margin-left: 40px;"><u>Cereal</u> <u>Tomato</u></p> <p>Ex: <u>Air</u> , <u>Salt Water</u></p> <p>Parts: <u>Oxygen</u> <u>Water</u></p> <p style="margin-left: 40px;"><u>Carbon Dioxide</u> <u>Salt</u></p>	<p style="text-align: center;"><u>Pure Substances</u></p> <p>Materials made of one substance</p> <p>Ex: <u>Water</u></p> <p style="margin-left: 40px;"><u>Oil</u></p> <p style="margin-left: 40px;"><u>Iron</u></p>
--	---

Matter Chart

4. Fill in the following words on the chart: physical properties, pure substance, matter, mixture.

Matter

Physical Property

Types: Color State of Matter
Shape/Size
Texture
Mass
Material

Mixture

→

Pure Substance

5. Physical property: Property that can be Measured or observed without changing the substance.

6. Physical properties of black ink are: black and liquid

7. Physical properties of paper are: white and smooth

8. Can all physical properties be used to separate mixtures? Yes No

9. What type of physical property was used to separate the black ink? attraction to water and paper

10. What do we know about the yellow ink? attracted to paper

11. What do we know about the blue ink? attracted to water

25

12. Determine how you would separate each mixture into two parts.

Mixture	List 3 Physical Properties of each part of the mixture		Helpful in Separating (circle one)	
	Water	Sand	<input checked="" type="radio"/> Yes	<input type="radio"/> No
	Liquid	Solid	<input checked="" type="radio"/> Yes	<input type="radio"/> No
	Clear	Brown	<input checked="" type="radio"/> Yes	<input checked="" type="radio"/> No
	light	Heavy	<input checked="" type="radio"/> Yes	<input type="radio"/> No

Is water a pure substance? Yes No

Is sand a pure substance? Yes No

13. Physical properties can be used to separate mixtures and identify pure substances.

14. Write down physical properties of the four substances. You will use these to identify four unknown substances. You will not have access to the labeled substances when you are identifying the unknown substances.

Pure Substance	Physical Properties	Unknown Letter
Sugar	Brown, small granules, many different shaped pieces	B
Salt	White, small granules, square shaped pieces	C
Baking Soda	White powder	A
Corn Starch	White powder, sticks to sides of bag, crunches when pinched	D

26

Preparation:

SciTrek Lead:

1. Get the conclusion assessments and put them in the lead box.
2. If the teacher is not leading the tie to standards activity, do the following:
 - a. Ask the teacher if they completed the SciTrek final survey. If not, give them the QR code from the lead box and ask them to go to the website (at a later time) and fill out the evaluation of the program.
 - b. Give the teacher an extra notebook and have them fill it out with their students to follow along during the tie to standards activity.
 - c. Collect the teacher's lab coat and put it in the lead box.
3. If you are a teacher and have not completed the SciTrek final survey, take the QR code from the lead box, and fill out the evaluation of the program, at a later time.
4. Pass out notebooks.
5. Set up the document camera for the tie to standards activity (notebook, pages 24-26; picture packet, pages 1, 5, and 6).
6. Tape the Matter Chart to the board.
7. Have mixture and pure substances available for use during the tie to standards activity.
8. Put your lab coat in the lead box at the end of the day.

Conclusion Assessment:
(10 minutes – Full Class – Given by Classroom Teacher Prior to SciTrek)

Tell students, "Before we start our activity today, we will determine how your ideas on conclusions are developing." Have students write their name, teacher's name, and date at the top of the assessment. Tell students, "When doing this assessment, you should work individually, so there should be no talking." As you are giving the assessment, walk around the room and verify students have written their names on their assessments.

For page 1 (top), read questions 1 and 2 aloud and give students time to answer each before moving on to the next question.

For page 1, question 3 (bottom), read the instructions to students. Then, read each of the statements aloud and have students circle whether the statement is an example of a claim, data, or opinion.

For page 2 (top), have students underline the controls, circle the changing variable(s), and box information about data collection on the results table. Then, have them decide if the group could make a conclusion, question 4.

For page 2, question 5 (bottom), read step 1 of the instructions aloud to students (*Identify the following statements as either CLAIM or DATA and write a C or D on the line.*). Then, have students fill in whether they think statement *a* is a claim or data by writing a C or D on the line. Tell students, "This part is similar to question 3 of the assessment." Read step 2 of the instructions aloud to students (*Look at the results table and circle if the statement is a correct claim, correct data, or incorrect. Statements are INCORRECT if the statement does not agree with the results table or has not been tested.*). Point to the results table and have students circle whether they think statement *a* is a correct claim, correct data, or incorrect claim or data. Once students have completed statement *a*, read statement *b* aloud and tell students, "Write a C or D on the line depending on whether you think the statement is a claim or data." After about 15 seconds tell students, "Now, look at the results table and circle whether the statement is a correct claim, correct data, or incorrect." Repeat the process for statements *c-e*.

For page 3, questions 6-7, repeat the process.

For page 4, question 8, tell students, “You are going to write a conclusion, or summarize what a scientist learned, by collecting the following data.” Point at the results table. Read the directions aloud to students and give them a few minutes to write a conclusion.

For page 5, tell students, “You are now going to decide if the following experiments can answer the following questions. Read question 9 to students, (*A student wants to study the following question: Does ramp height affect the distance traveled? Will the students be able to answer their question by carrying out the following two trials?*). Point to the picture for trial 1 and trial 2 and tell students, “These pictures pictorially represent the values of the variable that we used in both trials.” Then have students circle their response. Repeat the process for questions 10 and 11.

For page 6, tell students, “You are going to design an experiment to answer the following question.” Read the question aloud to the students (*Does mass affect the distance traveled?*). Tell students, “You will set up two trials to test this question.” Read the variables aloud to students. Point to the *Trial 1* table and tell students, “In this table, circle the values for each variable that you would use for your first trial.” Point to the *Trial 2* table and tell students, “In this table, circle the values for each variable that you would use for your second trial.” Then have students answer questions 12.

For page 6 (bottom) and 7, read the *Attitudes Towards Science* questions (13-23) to students and have students answer them. When they are finished, collect the assessments and verify that the students’ names are on the top of the papers.

Draw a Scientist:

(5 minutes – Full Class – SciTrek Lead)

Pass out a *Draw a Scientist* paper to each student and have them write their name, teacher’s name, and date at the top of the paper. Tell students, “I am going to give you **exactly** 4 minutes to draw a picture of what you think a scientist looks like.” Start the timer and when 3 minutes is up, give students a 1-minute warning. After 4 minutes is over tell students, “If you drew a specific person, on the line at the bottom of the paper write who you drew. If you did not draw a specific person, leave the line blank.” When students are finished, collect the papers and verify the students’ names are written on the top of the paper.

Tie to Standards:

(45 minutes – Full Class – SciTrek Lead)

Mysterious Robbery (12 minutes)

Tell students, “10 years ago a robbery happened which was never solved. The police have contacted us to help them solve the cold case. At the time of the crime, a note, written in black pen, was passed to the teller which read ‘Give me all your money.’ The teller handed over the money but kept the note. In the confusion that followed, the robber managed to get away. At the time, there were eight suspects. Each of these suspects was found with a black pen on the, which the police still have. The only other evidence the police have from the original crime was the note. No fingerprints were found on the note or at the scene of the crime. How could we figure out who wrote this note using the skills and knowledge learned from your experiments?” If students are having trouble generating responses, prompt them by asking what they did in their experiments and have students expand on these ideas. Make sure by the end of the conversations that students know that the police can determine the identity of the thief by determining the unique properties of each pen. The robber will be the suspect where the ink from the paper and the ink from their pen show the same properties.

Ask students, “Would it be easier to identify the robber’s pen from a shorter or taller smear?” Students should realize the taller the smear, the more details they could learn about the dyes used in the pen.

Therefore, teller smears would make it easier to tell the pens apart and identify the robber. Tell students, “The police have suggested several values for different variables that could be used to run the experiment, but they need your help in identifying the best values for the variables.” Have students turn to page 24 of their notebooks and fill out the chart together.

Ask students, “Which amount of time would allow the smear to be the tallest?” Possible student response: the longer the time in the liquid, the taller the smear, therefore, the ‘best’ choice would be 10 minutes. Circle *10 min* in the class notebook and have students do the same. An example can be seen below.

1. Circle the value of the variable that the police should use to process the evidence from the suspects that would give them the tallest smear.			
Time:	3 min	5 min	10 min
			All would give similar height smears

Now ask students, “Which liquid type would allow the smear to be the tallest?” Possible student response: the thinner the liquid, the taller the smear, therefore, since soap and syrup are thick liquids, the ‘best’ choice would be water. Circle *Water* in the class notebook and have students do the same. An example can be seen below.

Liquid Type:	Water	Soap	Syrup	All would give similar height smears
--------------	-------	------	-------	--------------------------------------

Now ask students, “Which liquid amount would allow the smear to be the tallest?” From their experiments, students should have seen the lower the liquid level, the longer it takes for the liquid to reach the dot. This leaves less time for the dot to smear, resulting in a shorter smear height. However, if the liquid level is above the dot and the dot is soluble in that liquid (smears in that liquid), the dot will start to dissolve into the liquid and will travel down into the liquid instead of up the paper. Therefore, the liquid level should be as close to the dot as possible, without going over the dot. Circle this response in the class notebook and have students do the same. An example can be seen below.

Amount of Liquid/Line Level:				All would give similar height smears
------------------------------	--	--	--	--------------------------------------

Once students have filled out the table, tell them, “The police took their suggestions and ran their experiments.” Show students the results of the experiment (picture packet, page 5).

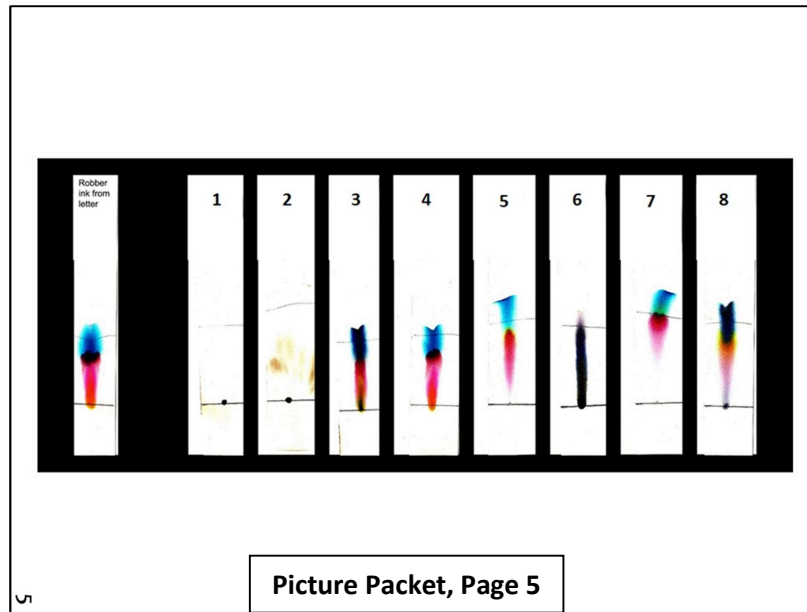

Have students look at the data and come up with a conclusion. Because there are no measurements on the strips, students will have to use observations for data. Therefore, make sure that they use the word “observed” in the data portion of the conclusion. Have students individually fill out the conclusions, then share them with the class. An example conclusion is shown below.

We can conclude that the robber was number four^{claim}
 because it was observed that the ink from^{data}
the robber and number four were the
same height and color.

Mixture Discussion (10 minutes)

Ask students, “What do you think these results imply about composition of the black ink?” Possible student response: black inks are composed of many different colored dyes, making them mixtures. Have students fill in question 3.

<u>Matter</u>	
Substances that Occupy Space and Have Mass	
<u>Mixture</u>	<u>Pure Substances</u>
Materials made of two or more substances	Materials made of one substance
EX: <u>Lucky Charms</u> , <u>Salad</u>	EX: <u>Water</u>
Parts: <u>Marshmallows</u> <u>Lettuce</u>	<u>Oil</u>
<u>Cereal</u> <u>Tomato</u>	<u>Iron</u>
EX: <u>Air</u> , <u>Salt Water</u>	
Parts: <u>Oxygen</u> <u>Water</u>	
<u>Carbon Dioxide</u> <u>Salt</u>	

3. What did we learn about black ink? It is a mixture

Matter Chart

Make sure that the *Matter Chart* is taped to the board. Ask students, “What is matter?” If they do not know, give them the definition (matter is anything that occupies space and has mass). Point to a few objects around the room and ask them if they are matter. These will all be matter. Ask students, “Are energy, ideas, and dreams, matter?” Students should reply, “No.” Write “matter” in the top box of the chart for question 4 while students copy it into their notebooks.

Ask students, “Is black ink matter?” Students should reply, “Yes.” Tell students, “All mixtures are matter.” Then, review the definition of a mixture with student (materials made up of two or more substances). Write “mixture” in the bottom left box of the chart for question 4, while students copy it into their notebooks. Tell students, “One example of a mixture is Lucky Charms” Have students give you the parts of the mixture (marshmallows and cereal), and record these on the *Matter Chart*. Then, have students generate at least one more mixture that can be distinguished by eye (Ex: trail mix – peanuts, raisins, M&Ms, etc.) and record it and its parts on the *Matter Chart*.

Tell students, “Sometimes you cannot see the individual parts of a mixture, like the ink from the black pens or the air. However, both of these are still mixtures of multiple substances.” Have students tell you the substances that make up air (oxygen, carbon dioxide, nitrogen, etc.) and record it on the *Matter Chart*. Then, have students generate at least one example of a mixture, they cannot tell, with their eyes, is a mixture (Ex: soda – water, sugar, dye, carbon dioxide, etc.), and record it and its parts on the *Matter Chart*.

Tell students, “Mixtures can be separated into pure substances.” Write “pure substances” in the bottom right box on the chart for question 4, while students copy it into their notebooks. Tell students, “Pure substances are materials that are composed of only one substance, for instance, water.” Have students generate two other pure substances (Ex: sugar, oil, salt, nitrogen, iron, etc.) and record them on the *Matter Chart*.

Note: Pure substances contain two categories: elements and compounds (substances made up of two or more elements). Sometimes students state that water is not a pure substance because it is composed of hydrogen and oxygen. If this happens, tell students, “In order to separate the hydrogen and oxygen in water, you would have to break chemical bonds and this would change the water into something else. If you had hydrogen atoms and oxygen atoms and you mixed them together, they would not form water without a chemical reaction occurring. For things to be a mixture, you have to be able to mix the parts back together to form the original mixture. Compounds can be separated into their elements using chemical properties, but this changes the substance and makes it so that the original substance cannot be reformed unless a chemical reaction occurs.” Do not go over this with students unless asked.

Tell students, “Mixtures and pure substances are related because all mixtures can be separated into their pure substances by taking advantage of differences in the physical properties of the substances that make up the mixture.” Write “physical property” on the line under “matter” on the chart for question 4, while students copy it into their notebooks.

Tell students, “A physical property is a property that can be measured or observed without changing the substance.” Then, have students tell you what to put in the blanks for question 5, while they copy them into their notebooks.

4. Fill in the following words on the chart: physical properties, pure substance, matter, mixture.

Matter

Physical Property
Types: Color State of Matter
Shape/Size
Texture
Mass
Material

Mixture

→

Pure Substance

5. Physical property: Property that can be Measured or observed without changing the substance.

Ask students, “What physical properties could you use to separate the Lucky Charms? Or, in other words, what could you measure or observe about Lucky Charms that you could use to separate it into its parts?” Students might generate the following: color, shape/size, texture, etc. As students generate these, record them under *Physical Property* on the chart for question 4. It is ok if not all of the blanks are filled in. More physical properties can be added as students identify them as the activity goes on.

Ask students, “What are physical properties of the black ink and paper?” Record these answers for question 6 and 7. If they generate a physical property that is not on the chart in question 4 (Ex: liquid), change it to a general physical property type (Ex: state of matter) and add it to the chart. If there is not enough room, put it in the margins beside the chart. Students do not need to write in the physical properties in the margins in their notebook.

6. Physical properties of black ink are: black and liquid

7. Physical properties of paper are: white and smooth

Ask students, “Is black ink a mixture or a pure substance?” Students should reply, “Mixture.” Ask students, “Can we separate the ink into its parts?” Students should reply, “Yes.” Ask students, “Can all physical properties be used to separate mixtures?” Lead students to understand even though we know the ink is made up of red, blue, etc. dyes, this will not help us separate the ink. Circle *No* for question 8, and have students do the same.

Ask students, “How were we able to separate out the different dye colors?” By the end of the conversation make sure students understand in order for the dot to smear out into its different dye parts, the paper had to be put into a liquid. Ask students, “Why do some dye colors travel further up the paper than others?” By the end of the conversation make sure students understand the dyes that traveled furthest up the paper were more attracted to the liquid than the paper and the dyes that moved very little were more attracted to the paper than the water. Tell students, “The types of physical properties that were used to separate the black ink were the attraction to the paper and the attraction to the water.” Record these in question 9 while students write them in their notebooks.

Show students the picture of a Day 1 strip (picture packet, page 1) and have students use it to answer questions 10 and 11. They should realize since the blue ink is high on the paper, it is attracted more to the liquid than the paper. Since the yellow ink did not move, it is attracted more to the paper than to the liquid.

8. Can all physical properties be used to separate mixtures? Yes No

9. What type of physical property was used to separate the black ink?
attraction to water and paper

10. What do we know about the yellow ink? attracted to paper

11. What do we know about the blue ink? attracted to water

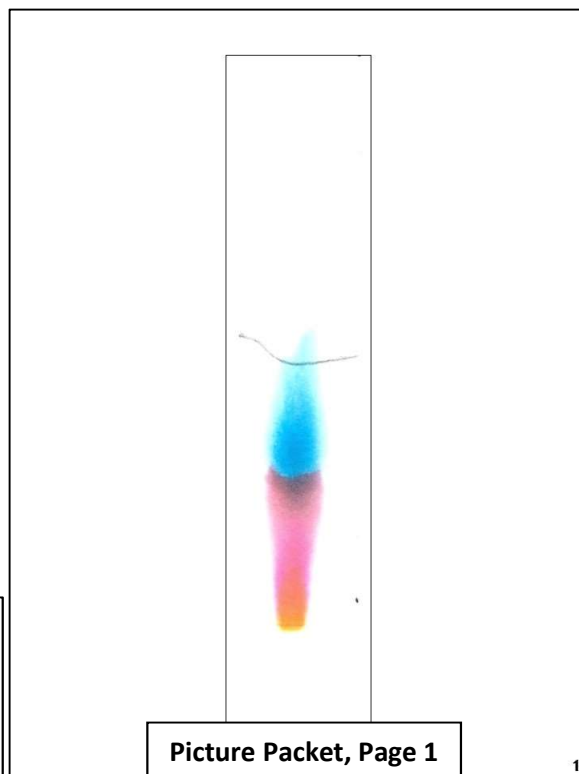

Picture Packet, Page 1

1

Separating Mixtures/Physical Properties (7 minutes)

Hold up the bottle of water and sand. Ask students, “Does the bottle contain a mixture or a pure substance and how do you know?” Possible student response: the bottle contains two different substances; therefore, it is a mixture. Ask them, “What physical property might you use to separate the two substances?” Students should notice that the water is a liquid and the sand is a solid. Write “liquid” under *water* and “solid” under *sand* on the chart for question 12. Ask students, “Will this property be useful in separating the mixture?” Then have students circle *Yes*. Have students generate two more physical properties (Ex: color and mass) as well as the value for both water and sand (Ex: clear and brown) and record the values in the chart. Then, have students identify whether or not the property would be useful in separating the mixture. If they generate physical properties that are not on the list in question 4, add them to the list.

12. Determine how you would separate each mixture into two parts.

Mixture	List 3 Physical Properties of each part of the mixture		Helpful in Separating (circle one)	
	Water	Sand		
	Liquid	Solid	Yes	No
	Clear	Brown	Yes	No
	Light	Heavy	Yes	No

Is water a pure substance? Yes No

Is sand a pure substance? Yes No

Have students determine if each component of the mixture is a pure substance. Students should understand that water is composed of only one material (water), so it is a pure substance. Circle *Yes*. Students should also understand that sand can be made up of many different types of rock fragments (this can be seen by all the grains of sand being different colors), therefore, it would take additional work to separate the sand into its pure substances. Circle *No*.

Pure Substances (16 minutes)

Tell students, “In addition to using physical properties to separate mixtures, physical properties can be used to identify pure substances.” Have students fill in question 13.

13. Physical properties can be used to separate mixtures and identify pure substances.

Pass out the labeled pure-substance bags. These four bags contain a single pure substance (sugar, salt, baking soda, or corn starch). Tell students, “You will be given a few minutes to identify physical properties of each of the pure substances, which you should record in your notebooks. You may touch and observe the bags, but you may not open any of the small bags. Once you have written down the physical properties, I will take away the labeled bags and give you four bags that are lettered A-D. You will then need to determine the identity of the pure substance based off your notes.”

Bag A = Baking Soda

Bag B = Sugar

Bag C = Salt

Bag D = Corn Starch

Once students have completed the activity, ask them to share the substance they identified for each lettered bag. Also, ask them, “What physical property was the most helpful in identifying the substance?” Once a student has shared, poll the class using thumbs up/thumbs down for agree/disagree with the student. If a student disagrees, have them explain why and share what physical property they used to identify the substance. Collect the bags from the students.

14. Write down physical properties of the four substances. You will use these to identify four unknown substances. You will not have access to the labeled substances when you are identifying the unknown substances.

Pure Substance	Physical Properties	Unknown Letter
Sugar	Brown, small granules, many different shaped pieces	B
Salt	White, small granules, square shaped pieces	C
Baking Soda	White powder	A
Corn Starch	White powder, sticks to sides of bag, crunches when pinched	D

Tell students, “You have taught me a lot about mixtures. I now know black ink is a mixture and I can use physical properties (such as the attraction of the ink to the paper) to separate the black ink into its parts. In addition, physical properties can also be used to describe pure substances.”

Content Assessment:

(10 minutes – Full Class – SciTrek Lead)

Have students close their notebooks, and place them in the corners of their desks. Pass out the content assessment to students. Have students write their name, teacher’s name, and date at the top of their assessments. Tell students, “When doing this assessment, you should work individually, so there should be no talking.” Read each of the content questions to the students and have them select/ fill out the correct answer. As you are giving the assessment, walk around the room and verify students have written their names on their assessments. When done, collect the assessments.

Tell students, "You can keep your notebooks, I have enjoyed working, and learning with you. I hope you will continue to see yourselves as scientists and explore the world around you."

Clean-Up:

1. Leave notebooks with students.
2. Place all other materials into the lead box and bring them back to UCSB.
3. Remove all materials from your lab coat pockets, remove your nametag, unroll your lab coat sleeves, and put your lab coat into the dirty clothes bag at UCSB.

Extra Practice Solutions:

EXTRA PRACTICE
Conclusions

Directions: On the results table, underline each control, circle each changing variable(s), and box information about data collection.

Variables	Trial A	Trial B
Time:	5 min	→
Liquid Type:	Water	Soap
Liquid Amount:	2 ml	→
Paper Type:	Original	→
Pen Color:	Red	→
Pen Type:	Mr. Sketch	→
Data	Trial A	Trial B
Smear Height:	4 cm	0.5 cm
Liquid Height:	6 cm	3 cm
Other:	Green Blue Red	Pink Orange

Can this group make a claim/conclusion? Yes No I Don't Know

Step 1: Step 2:
 Statement Based on the table, is the statement a
 Type: C or D correct claim, correct data, or incorrect?

1. the height of the smear in water was 4 cm and the height of the smear in soap was 0.5 cm. D Correct Claim Correct Data Incorrect
2. the type of liquid does not affect the smear height. C Correct Claim Correct Data Incorrect
3. with 2 ml of liquid, the thicker liquid results in a shorter smear height. C Correct Claim Correct Data Incorrect
4. the color of the pen affects the smear height. C Correct Claim Correct Data Incorrect
5. the liquid type affects the smear height. C Correct Claim Correct Data Incorrect

What data can be used to support the correct claim(s) above? The thicker liquid (soap) had a 0.5 cm high smear and the thinner liquid (water) had a 4 cm high smear.

27